



PT16755 LED Driver test report

Parameter	Specifications
Topology	SEPIC
Input voltage range	8~40V
Output voltage range	9~51V (3~17 LEDs)
Output current	100~1000mA
Efficiency (Input voltage = 14 V, 8 LEDs, ILED = 500 mA)	≈91%
Switching frequency	400 kHz
Over-voltage protection	57V



1. Schematic

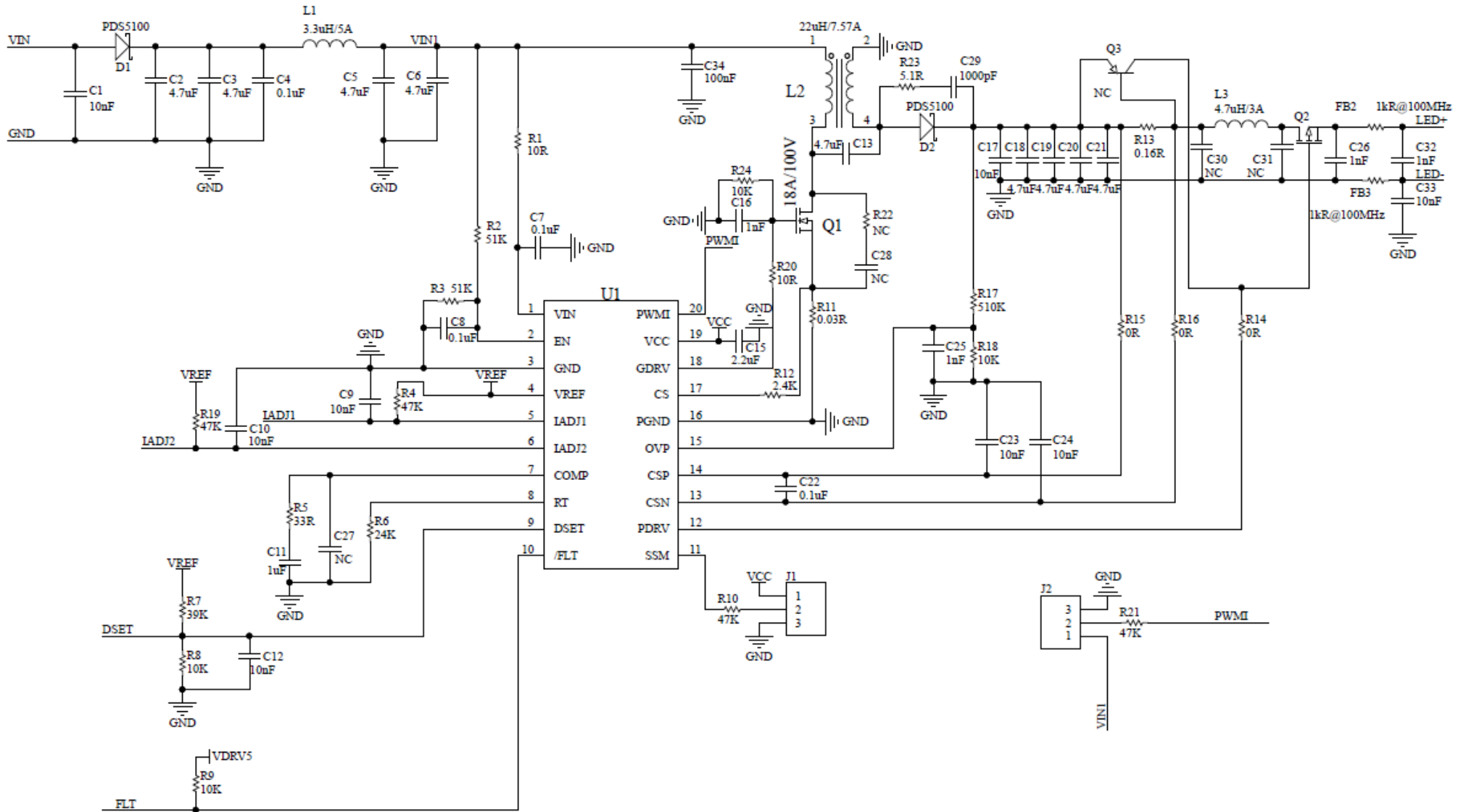

Figure 1. Schematic



2. BOM

Designator	Qty	Value	Description	Package
C1, C17, C23, C24	4	10nF	CAP, CERM, 10-nF, 100 V, +/- 10%, X7R	0805
C2, C3, C5, C6, C13 C18, C19, C20, C21	9	4.7uF	CAP, CERM, 4.7-uF,100V, +/- 10%, X7R	1210
C4, C7, C8	3	0.1uF	CAP, CERM, 0.1-μF, 100 V, +/- 10%, X7R	0805
C9, C10, C12, C33	3	10nF	CAP, CERM, 10-nF,25V, +/- 10%, X7R	0805
C11	1	1uF	CAP, CERM, 1-μF, 25 V, +/- 10%, X7R	0805
C15	1	2.2uF	CAP, CERM, 2.2-uF, 25 V, +/- 10%, X7R	0805
C22	1	0.1uF	CAP, CERM, 0.1-uF, 25 V, +/- 10%, X7R	0805
C25, C29	2	1nF	CAP, CERM, 1-nF, 25 V, +/- 10%, X7R	0805
C26	1	1nF	CAP, CERM, 1-nF, 100 V, +/- 10%, X7R	0805
D1, D2	2	PDS5100Q	Diode, Schottky, 100-V, 5-A, AEC-Q101	PowerDI5
L1	1	3.3uH	Inductor, Shielded, Ferrite, 3.3-uH, 6.8-A	7.1mmX6.5mm
L2	1	22uH	Coupled inductor, 22-uH, 7.57-A (SRF1280A-220M)	12.5mmX12.5mm
L3	1	4.7uH	Inductor, Shielded, Ferrite, 4.7-uH, 3.9-A	4.1mmX4.1mm
Q1	1	SQJ476	MOSFET, N-CH, 100-V, 23-A, AEC-Q101 (SQJ476,AEC-Q101)	PowerPAK SO-8L
Q2	1	DMP6185SEQ-13	MOSFET, P-CH, 60-V, 3-A, AEC-Q100	SOT223
Q3	1	S8550	PNP, -40V, -0.5A	SOT-23
R1, R20	4	10Ω	RES, 10-Ω, 1%, 0.125-W	0805
R2, R3	2	51K	RES, 51-kΩ, 1%, 0.125-W	0805
R4, R10, R19, R21	4	47K	RES, 47-kΩ, 1%, 0.125-W	0805
R5	1	33Ω	RES, 33-Ω, 1%, 0.125-W	0805
R6	1	24K	RES, 24-kΩ, 1%, 0.125-W	0805
R7	1	39K	RES, 39-kΩ, 1%, 0.125-W	0805
R8, R9, R18	3	10K	RES, 10-kΩ, 1%, 0.125-W	0805
R11	1	0.03Ω	RES, 0.03-Ω, 1%, 1-W	2512
R12	1	2.4K	RES, 2.4-kΩ, 1%, 0.125-W	0805
R13	1	0.16Ω	RES, 0.16-Ω, 1%, 0.5-W	1210
R14, R15, R16	3	0Ω	RES, 0-Ω, 1%, 0.125-W	0805
R17	1	560K	RES, 560-kΩ, 1%, 0.125-W	0805
R23	1	5.1Ω	RES, 5.1-Ω, 1%, 0.125-W	0805
FB2, FB3	2	1KΩ@100MHz/2A	Ferrite Beads 1KΩ@100MHz/2A	1206
U1	1	PT16755	Multi-Topology Automotive Headlight LED Driver	HTSSOP20

3. Performance Data and Typical Characteristic Curves

3.1 Efficiency (D1 removed)

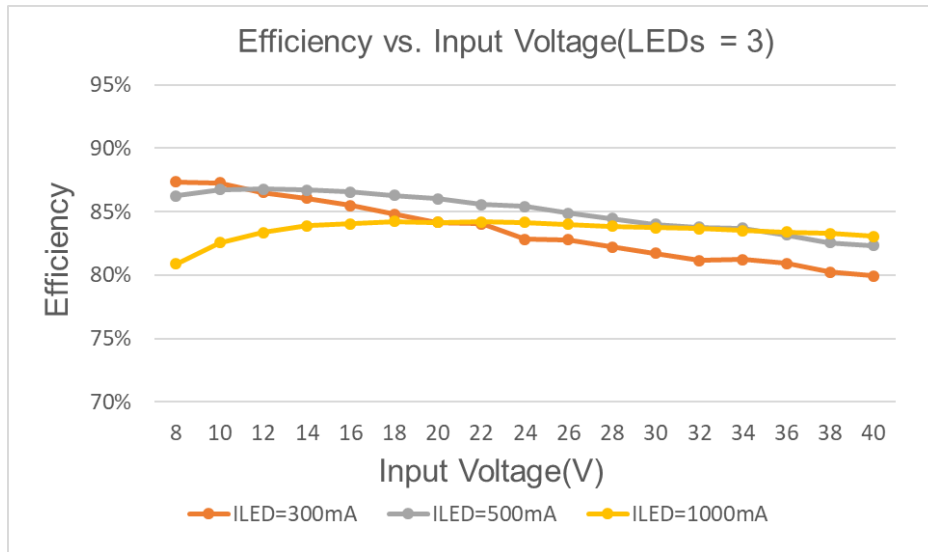

Figure 2. Efficiency vs Input Voltage (Number of Series-Connected LEDs = 3)

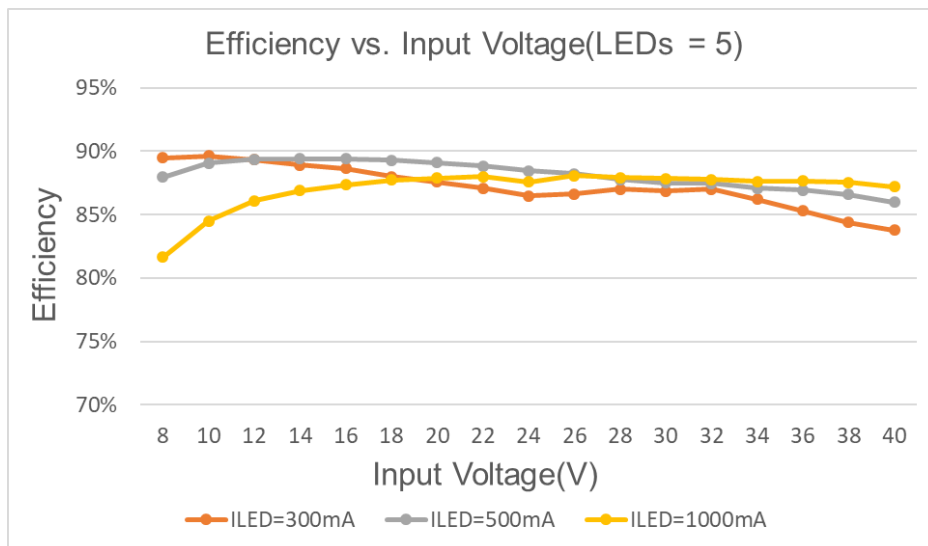

Figure 3. Efficiency vs Input Voltage (Number of Series-Connected LEDs = 5)

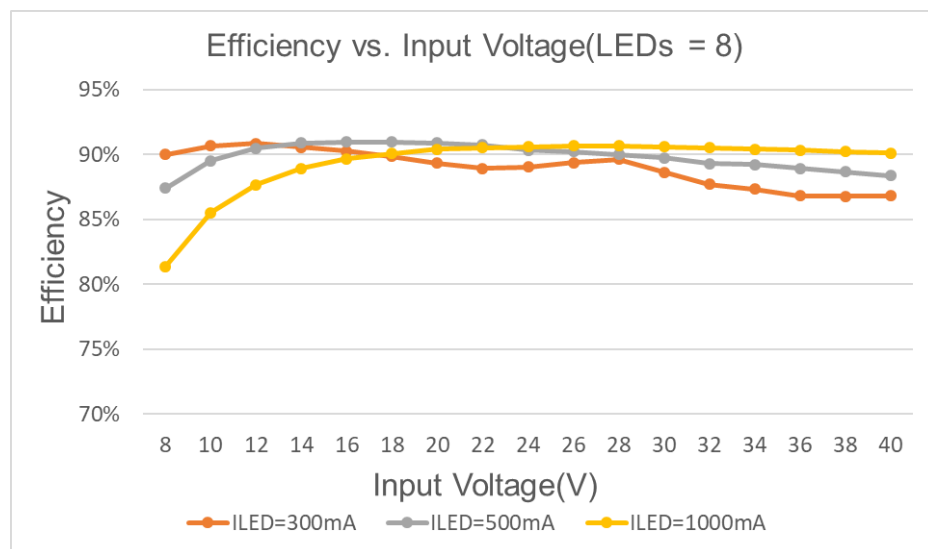

Figure 4. Efficiency vs Input Voltage (Number of Series-Connected LEDs = 8)

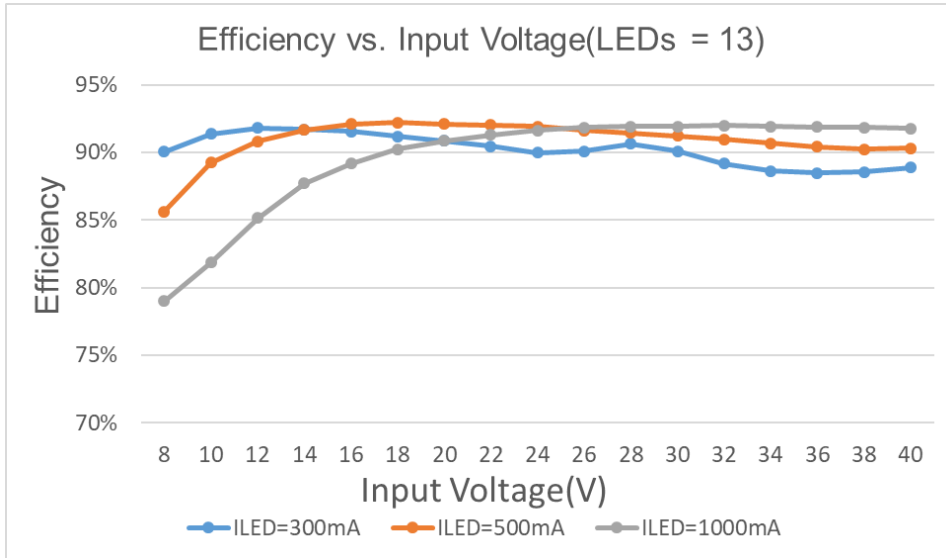

Figure 5. Efficiency vs Input Voltage (Number of Series-Connected LEDs = 13)

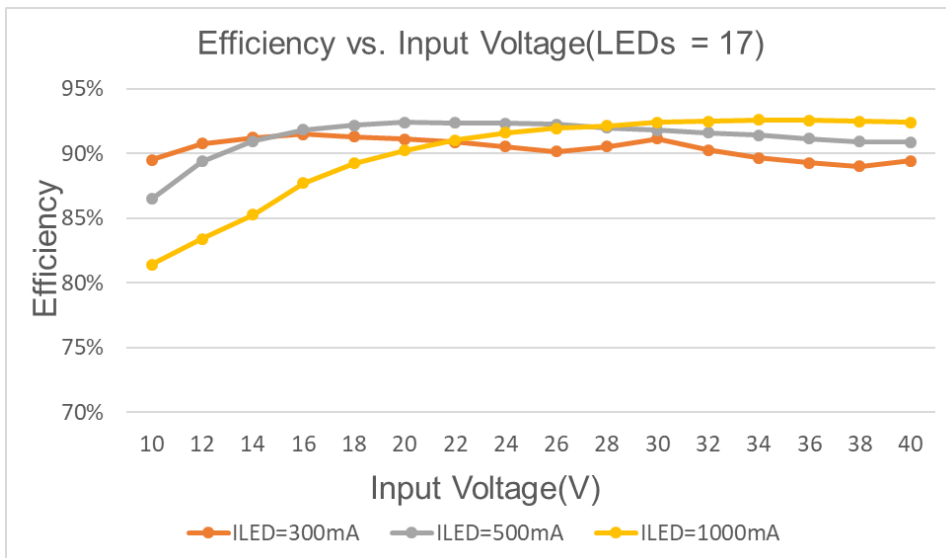

Figure 6. Efficiency vs Input Voltage (Number of Series-Connected LEDs = 17)

3.2 Line Regulation

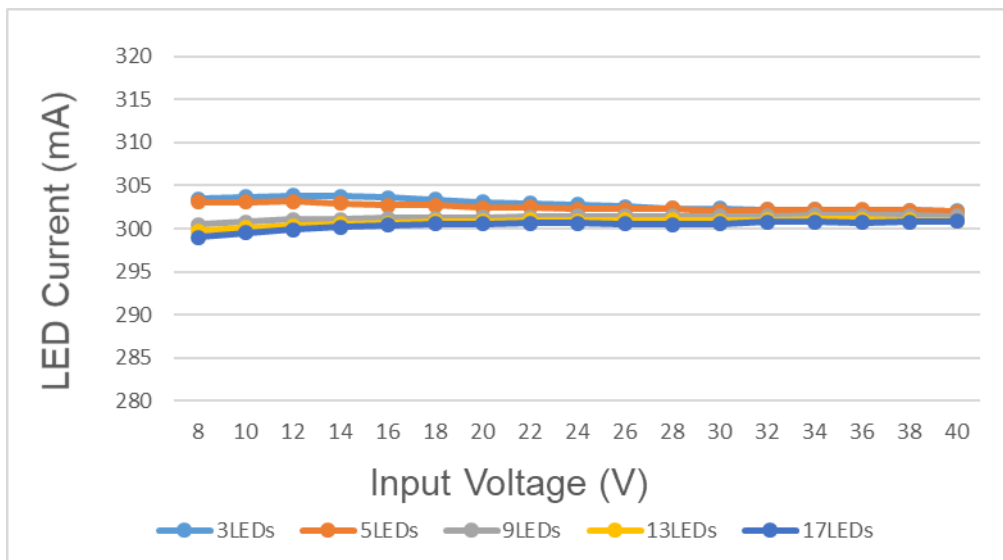

Figure 7. Output LED Current vs Input Voltage ($I_{out} = 300mA$)

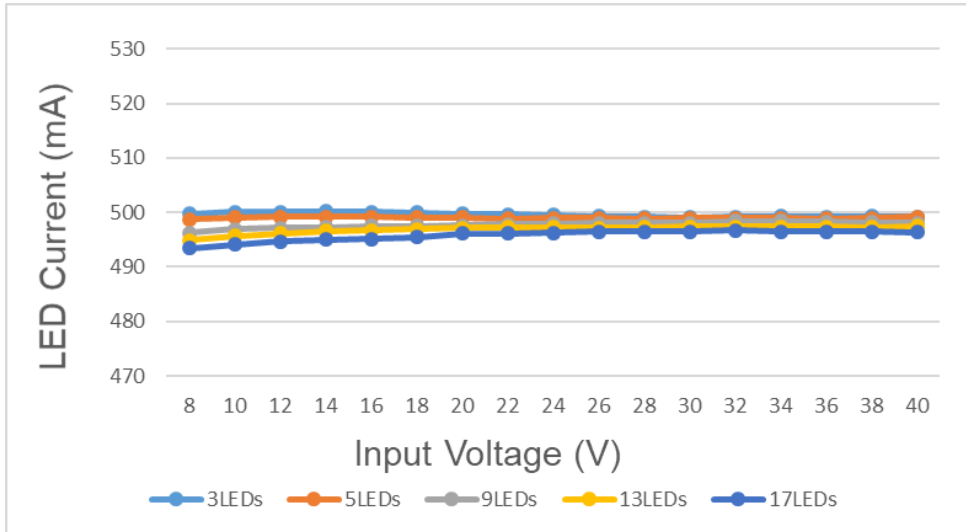

Figure 8. Output LED Current vs Input Voltage (I_{OUT} = 500mA)

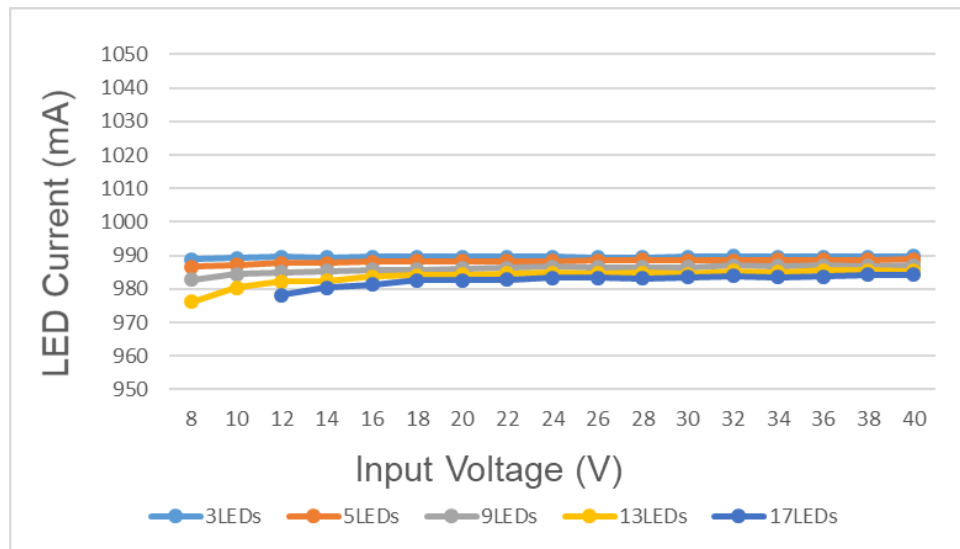

Figure 9. Output LED Current vs Input Voltage (I_{OUT} = 1000mA)

3.3 Load Regulation

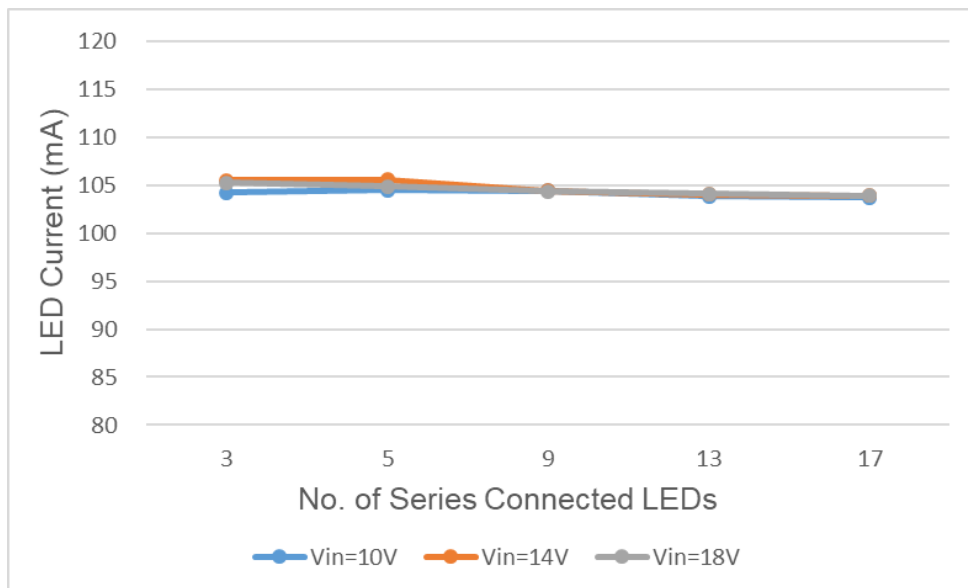

Figure 10. Output LED Current vs LED String Configuration (I_{OUT} = 100 mA)

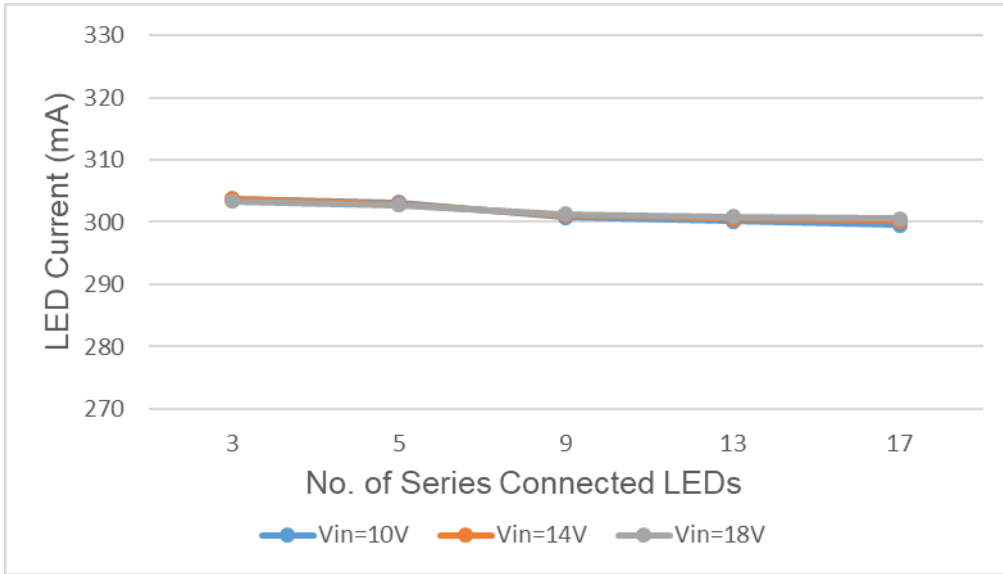

Figure 11. Output LED Current vs LED String Configuration ($I_{OUT} = 300 \text{ mA}$)

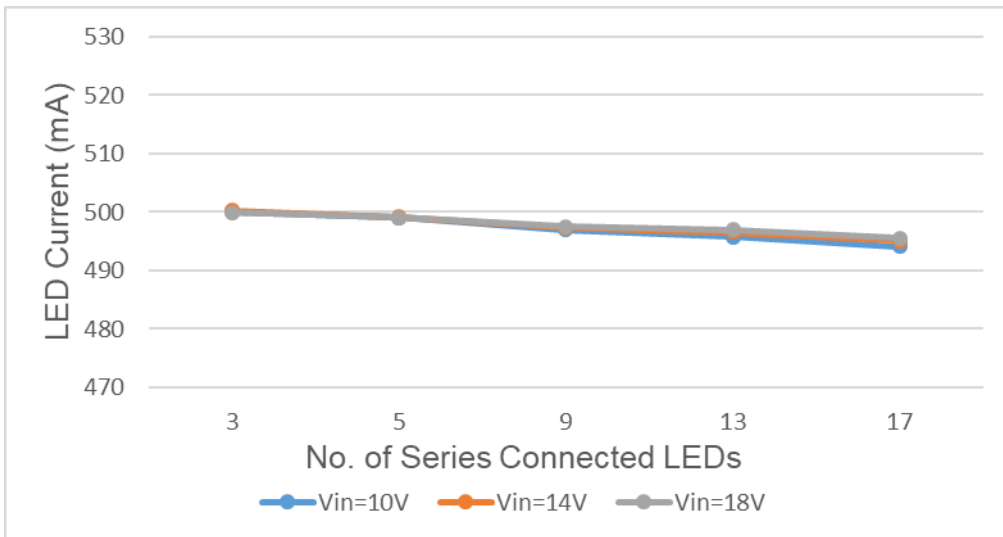

Figure 12. Output LED Current vs LED String Configuration ($I_{OUT} = 500 \text{ mA}$)

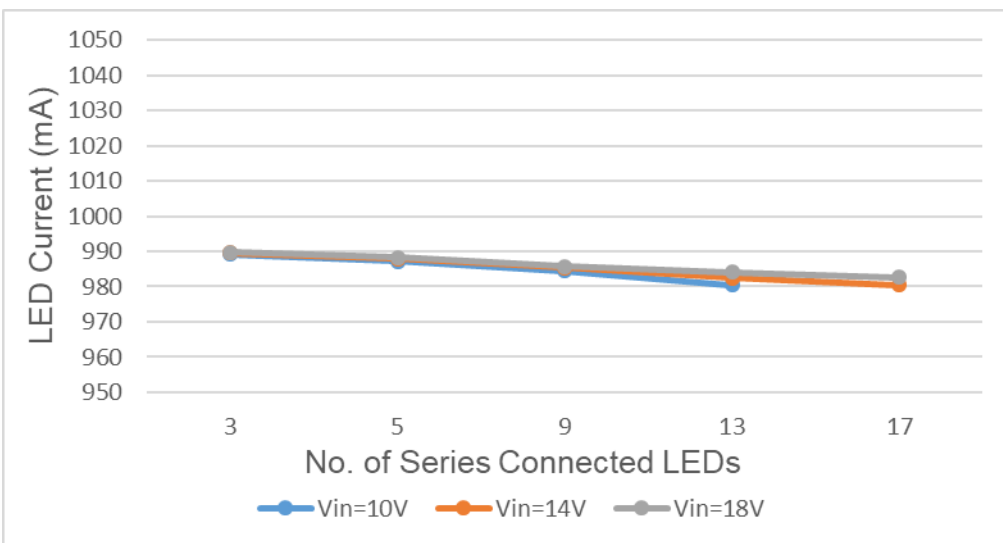

Figure 13. Output LED Current vs LED String Configuration ($I_{OUT} = 1000 \text{ mA}$)

3.4 PWM Dimming

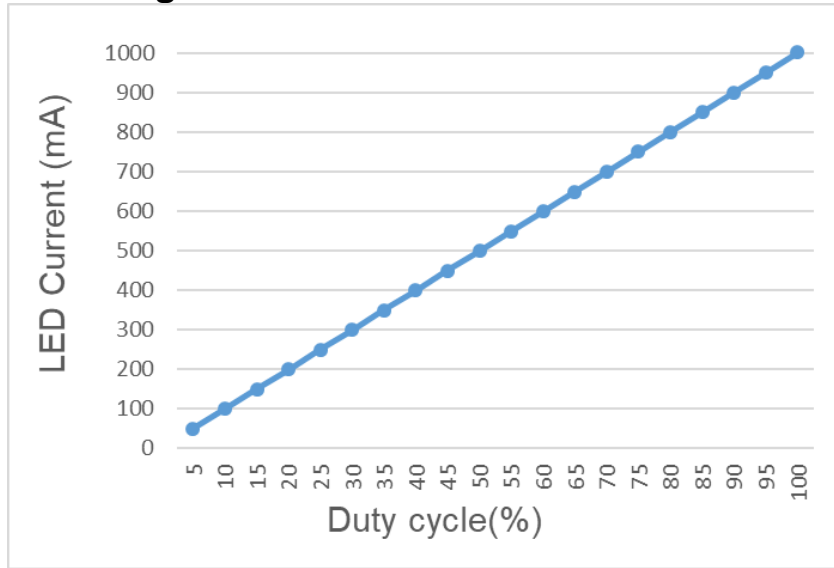

Figure 14. Output LED Current vs PWM Duty cycle ($V_{in}=14V$, $I_{out} = 1000 \text{ mA}$, 8LEDs)

3.5 DSET Voltage to PWM Dimming

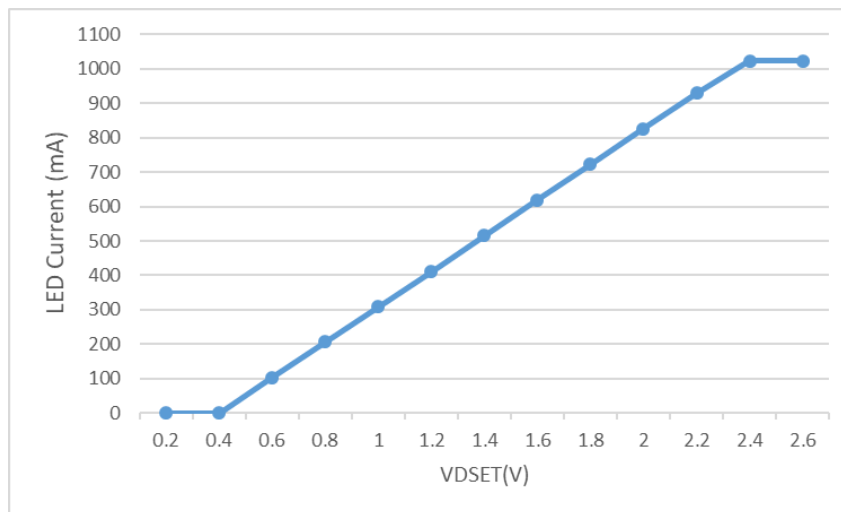

Figure 15. LED Current vs DIM/PWM Voltage ($V_{in}=14V$, Number of LED Series=8)

3.6 Analog Dimming

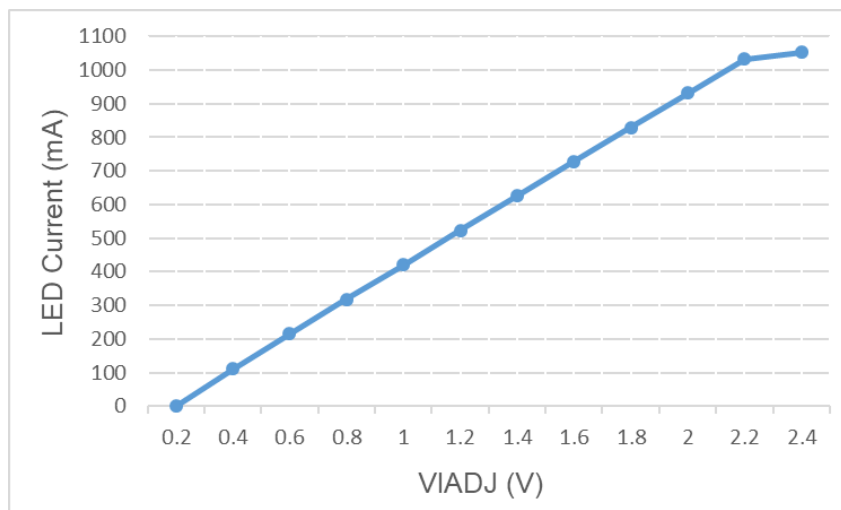
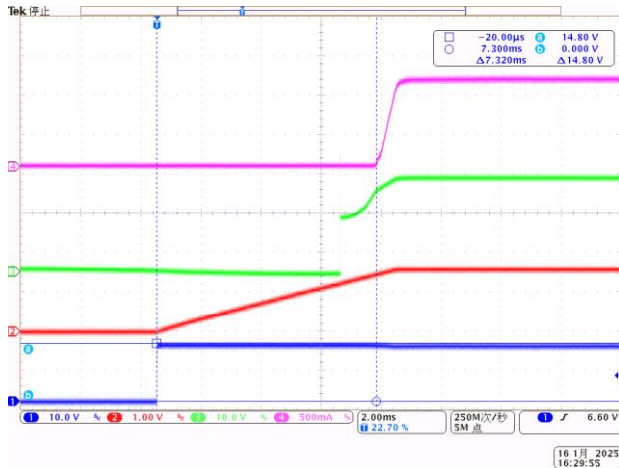
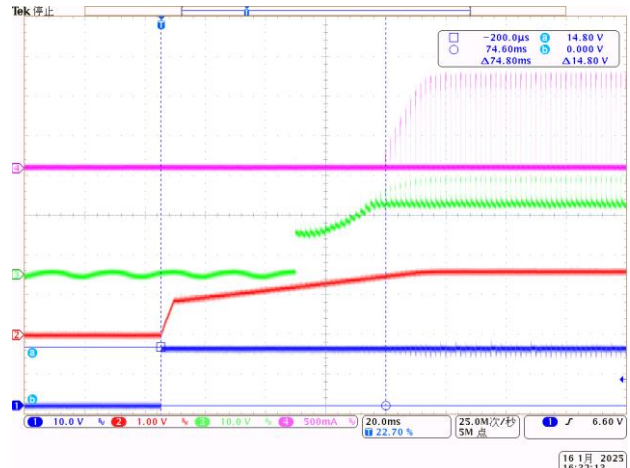

Figure 16. LED Current vs IADJ Voltage ($V_{in}=14V$, Number of LED Series=8)

4. Typical Waveforms



CH1: EN
CH2: COMP
CH3: VOUT
CH4: ILED
Time: 2-ms/div
Figure 18. EN Power ON (DRL Mode)



CH1: EN
CH2: COMP
CH3: VOUT
CH4: ILED
Time: 20-ms/div
Figure 19. EN Power ON (PWM Mode)

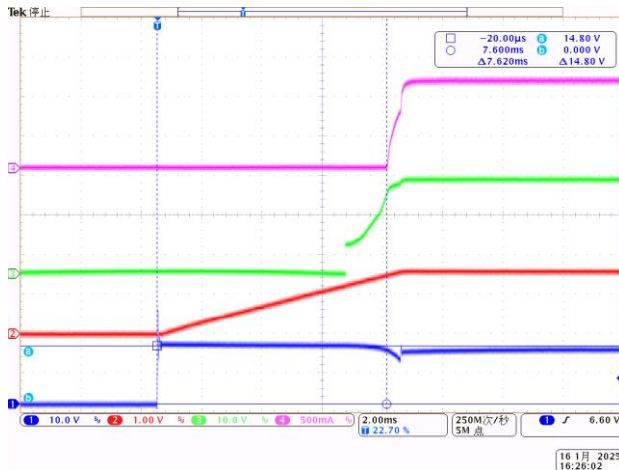

CH1: VIN
CH2: COMP
CH3: VOUT
CH4: ILED
Time: 2-ms/div
Figure 20. VIN Power ON (DRL Mode)

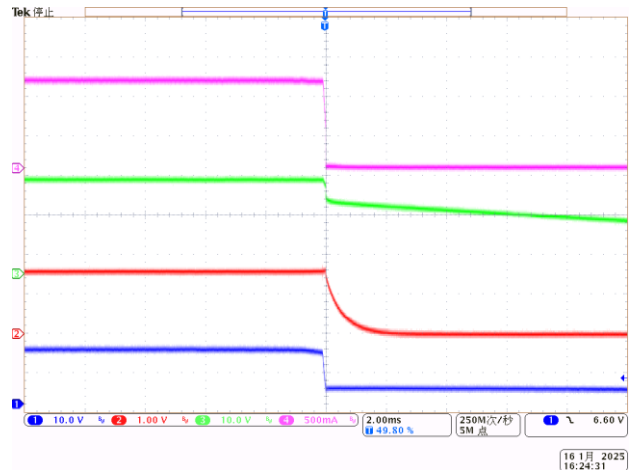

CH1: VIN
CH2: COMP
CH3: VOUT
CH4: ILED
Time: 2-ms/div
Figure 21. VIN Power OFF (DRL Mode)

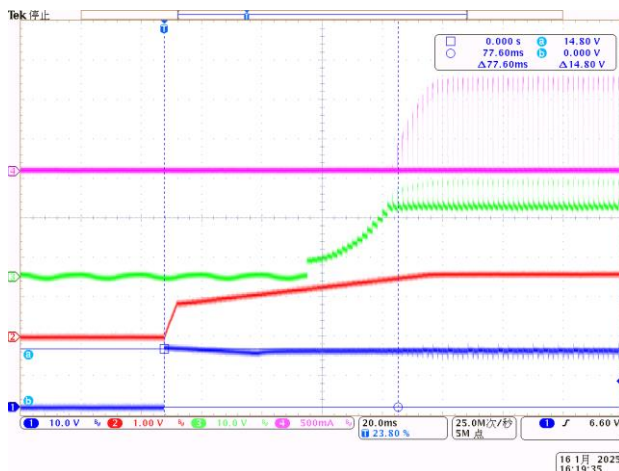

CH1: VIN
CH2: COMP
CH3: VOUT
CH4: ILED
Time: 20-ms/div
Figure 22. VIN Power ON (PWM Mode)

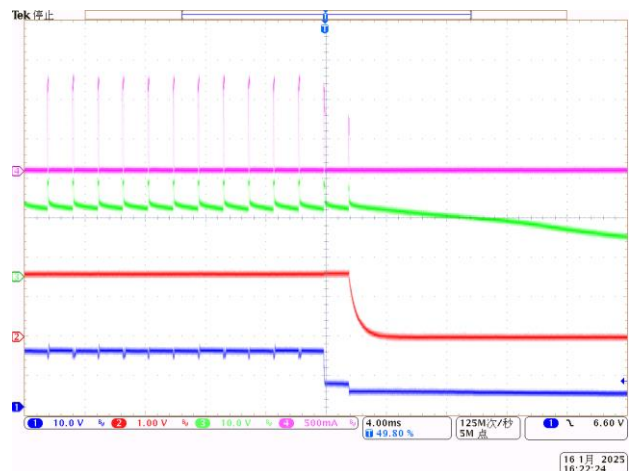

CH1: VIN
CH2: COMP
CH3: VOUT
CH4: ILED
Time: 4-ms/div
Figure 23. VIN Power OFF (PWM Mode)

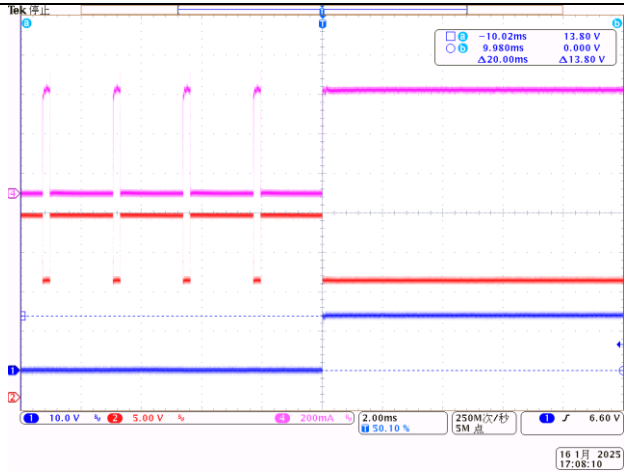

CH1: PWMI
 CH2: PDRV
 CH4: ILED
 Time: 2-ms/div
 Figure 24. PWM Mode → DRL Mode



CH1: PWMI
 CH2: PDRV
 CH4: ILED
 Time: 2-ms/div
 Figure 25. DRL Mode → PWM Mode

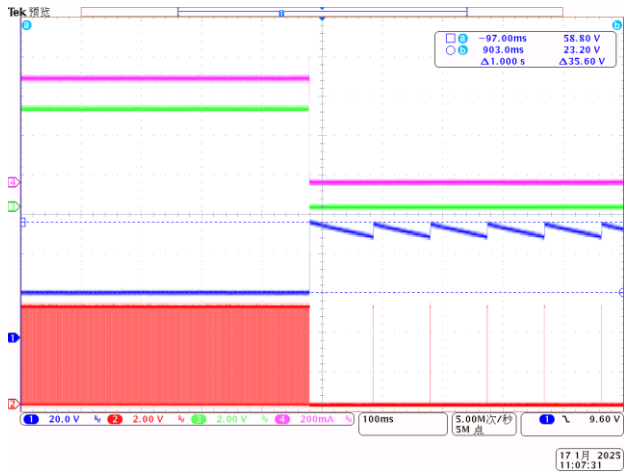

CH1: VCSP
 CH2: GDRV
 CH3: /FLT
 CH4: ILED
 Time: 100-ms/div
 Figure 26. LED Open Operation (Normal → Open)
 DRL Mode

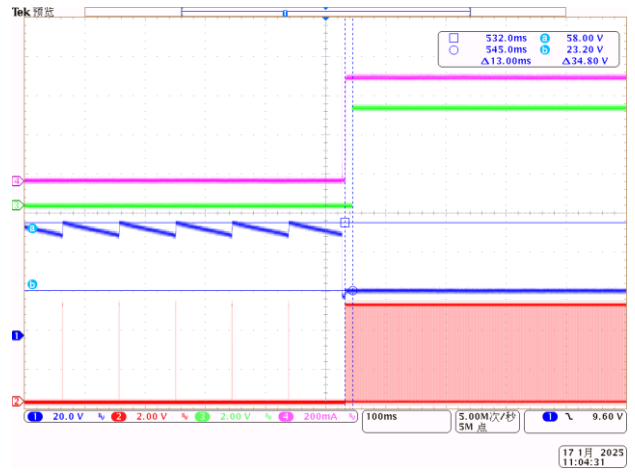

CH1: VCSP
 CH2: GDRV
 CH3: /FLT
 CH4: ILED
 Time: 100-ms/div
 Figure 27. LED Open Operation (Open → Normal)
 DRL Mode

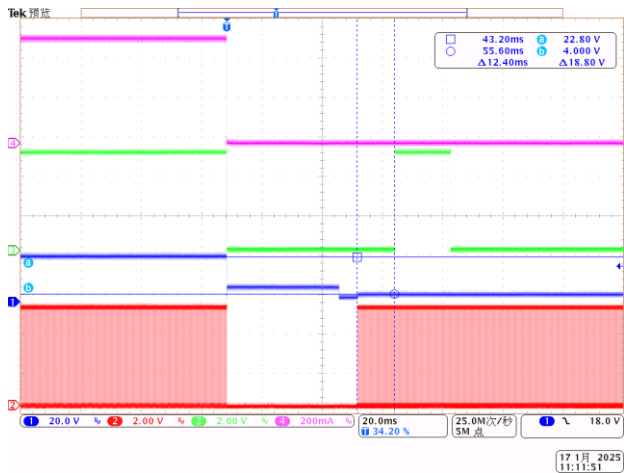

CH1: VCSP
 CH2: GDRV
 CH3: /FLT
 CH4: ILED
 Time: 20-ms/div
 Figure 28. SCP Operation (Normal → Short)
 DRL Mode

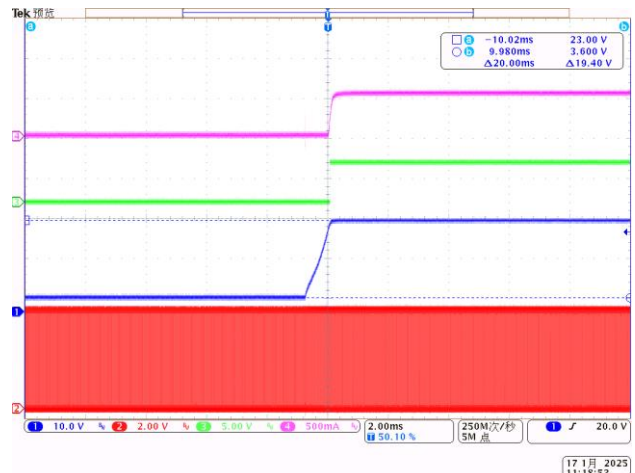

CH1: VCSP
 CH2: GDRV
 CH3: /FLT
 CH4: ILED
 Time: 2-ms/div
 Figure 29. SCP Operation (Short → Normal)
 DRL Mode

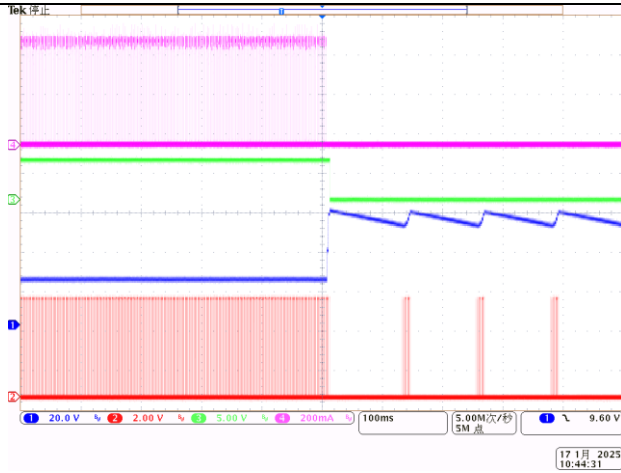

CH1: VCSP CH2: GDRV
CH3: /FLT CH4: ILED
Time: 100-ms/div
Figure 30. LED Open Operation (Normal → Open)
PWM Mode

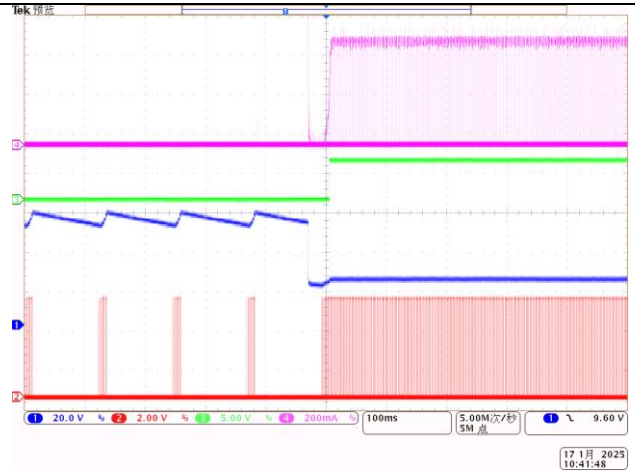

CH1: VCSP CH2: GDRV
CH3: /FLT CH4: ILED
Time: 100-ms/div
Figure 31. LED Open Operation (Open → Normal)
PWM Mode

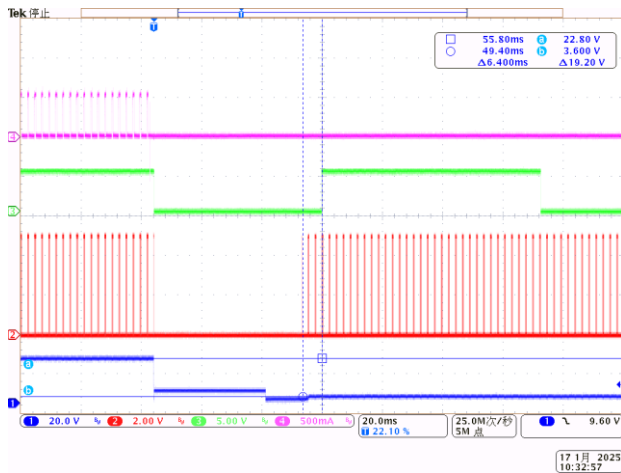

CH1: VCSP CH2: GDRV
CH3: /FLT CH4: ILED
Time: 20-ms/div
Figure 32. SCP Operation (Normal → Short)
PWM Mode

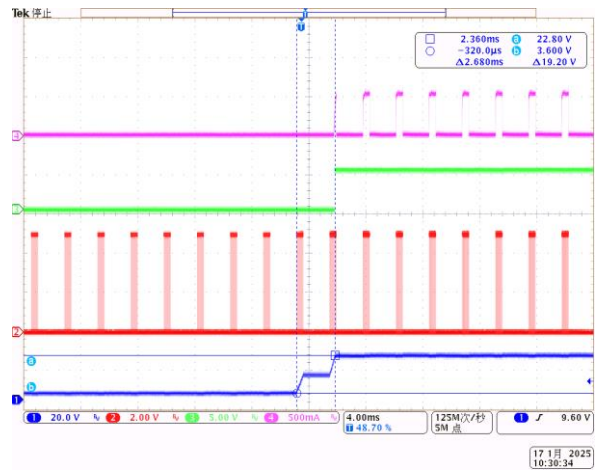

CH1: VCSP CH2: GDRV
CH3: /FLT CH4: ILED
Time: 4-ms/div
Figure 33. SCP Operation (Short → Normal)
PWM Mode

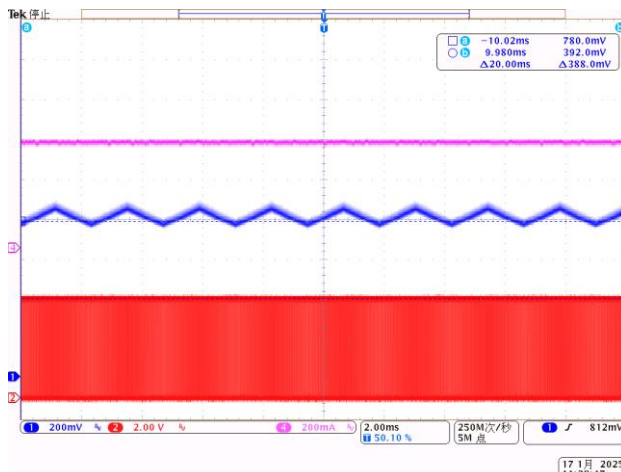

CH1: RT CH2: GDRV
CH4: ILED
Time: 2-ms/div
Figure 34. SSFM Operation (DRL Mode)

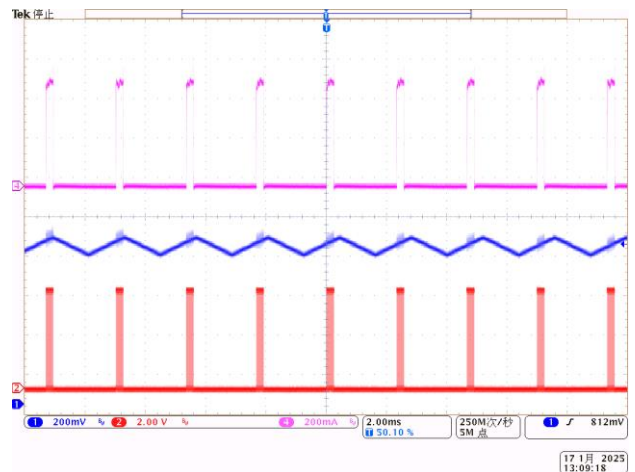

CH1: RT CH2: GDRV
CH4: ILED
Time: 2-ms/div
Figure 35. SSFM Operation (PWM Mode)



5. EMI Conduction

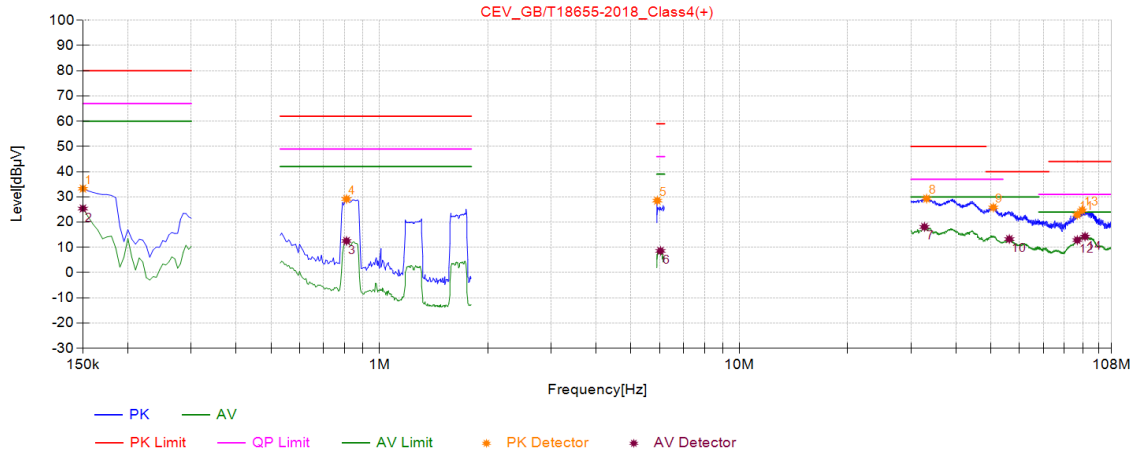

Positive

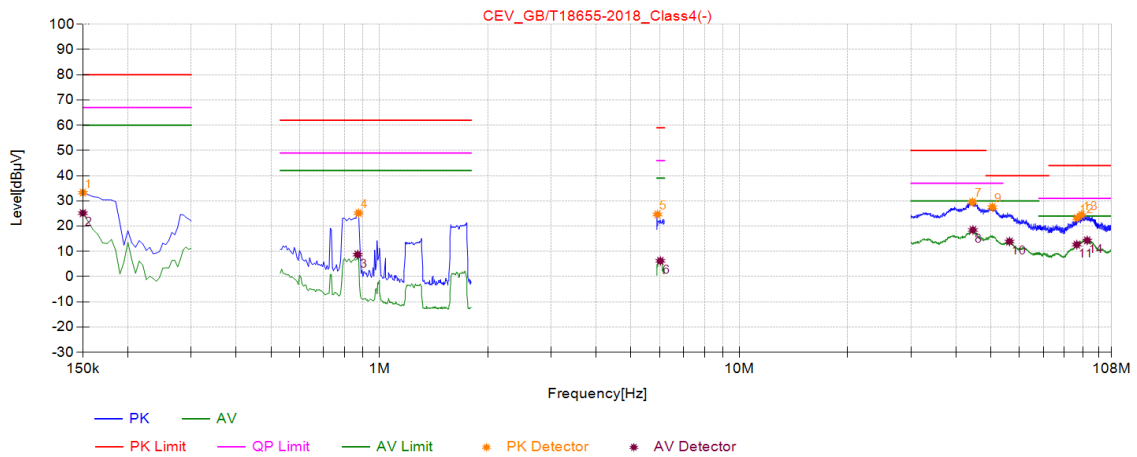

Negative

6. PCB Layout and information

Material	FR-4
Board thickness	1.6mm
Copper thickness	1 oz
Number of layers	4

