

DESCRIPTION

PT16976 is a linear LED controller for automotive exterior lighting. The controller drives an external NPN transistor to regulate a current for LED lamps. The typical application of the device is a rear combination lamps for automotive. A single driver gives the user flexibility to add single channels to multichannel systems. LED brightness can be easily programmed using a single resistor in series with the NPN transistor. It gives the user the flexibility to use the device over a wide range of currents.

A single controller can drive multiple strings of LEDs. The controller provides a dedicated dimming function via the PWM input. Setback current limit function helps to reduce the device power consumption during overvoltage conditions.

Additional fault protection features include open load and short circuit protection, the controller is turned off when an open load or short circuit is detected.

The device is available in a SOP8 package.

FEATURE

- Automotive AEC-Q100, Grade 1 (-40°C ~+125°C) Qualified
- Programmable LED Current Using a Single Resistor
- Constant Current Output for LED String Drive
- External NPN transistor Device for Wide Current Range
- Pulse Width Modulation (PWM) Control
- Negative Temperature Coefficient Current Control Option
- Open LED String Diagnostic
- Short-Circuit LED String Diagnostic
- Multiple LED String Control
- Overvoltage Set Back Power Limitation
- SOP8 Package

APPLICATION

- Rear Combination Lamps (RCL)
- Daytime Running Lights (DRL)
- Turn Signal
- Center High Mounted Stop Lamps (CHMSL) Arrays
- Fog Lights
- General Linear Current LED Driver

TYPICAL APPLICATION

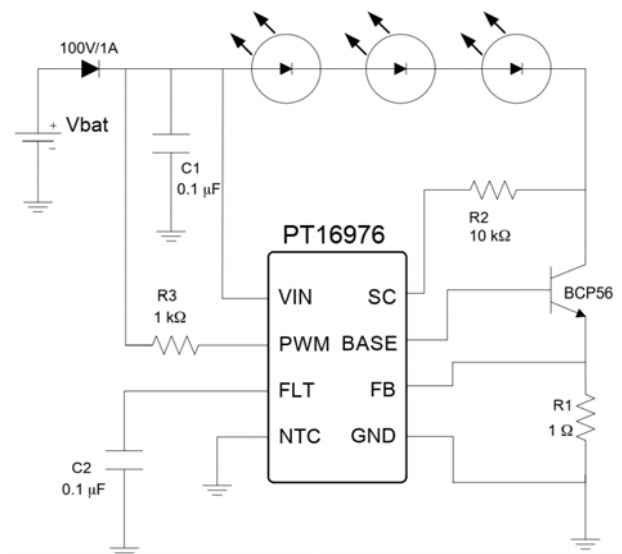

ORDER INFORMATION

Valid Part Number	Package Type	Top Code
PT16976-S	8 Pins, SOP	PT16976-S

PIN CONFIGURATION

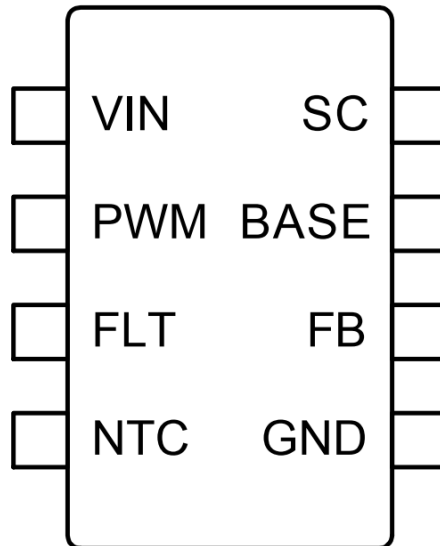

PIN DESCRIPTION

Pin Name	Description	Pin No.
VIN	Power supply input	1
PWM	Logic input for Enable and PWM dimming. Pull high for device on.	2
FLT	A capacitor to ground sets the time for open circuit, short circuit, and over-temperature detection.	3
NTC	Optional input for Negative Temperature Coefficient performance. Ground this pin if Negative Temperature Coefficient is not used.	4
GND	Ground	5
FB	Feedback sense node for current regulation	6
BASE	Base Drive for external NPN transistor	7
SC	LED Short Circuit Detection Input. Ground pin if not used.	8

BLOCK DIAGRAM

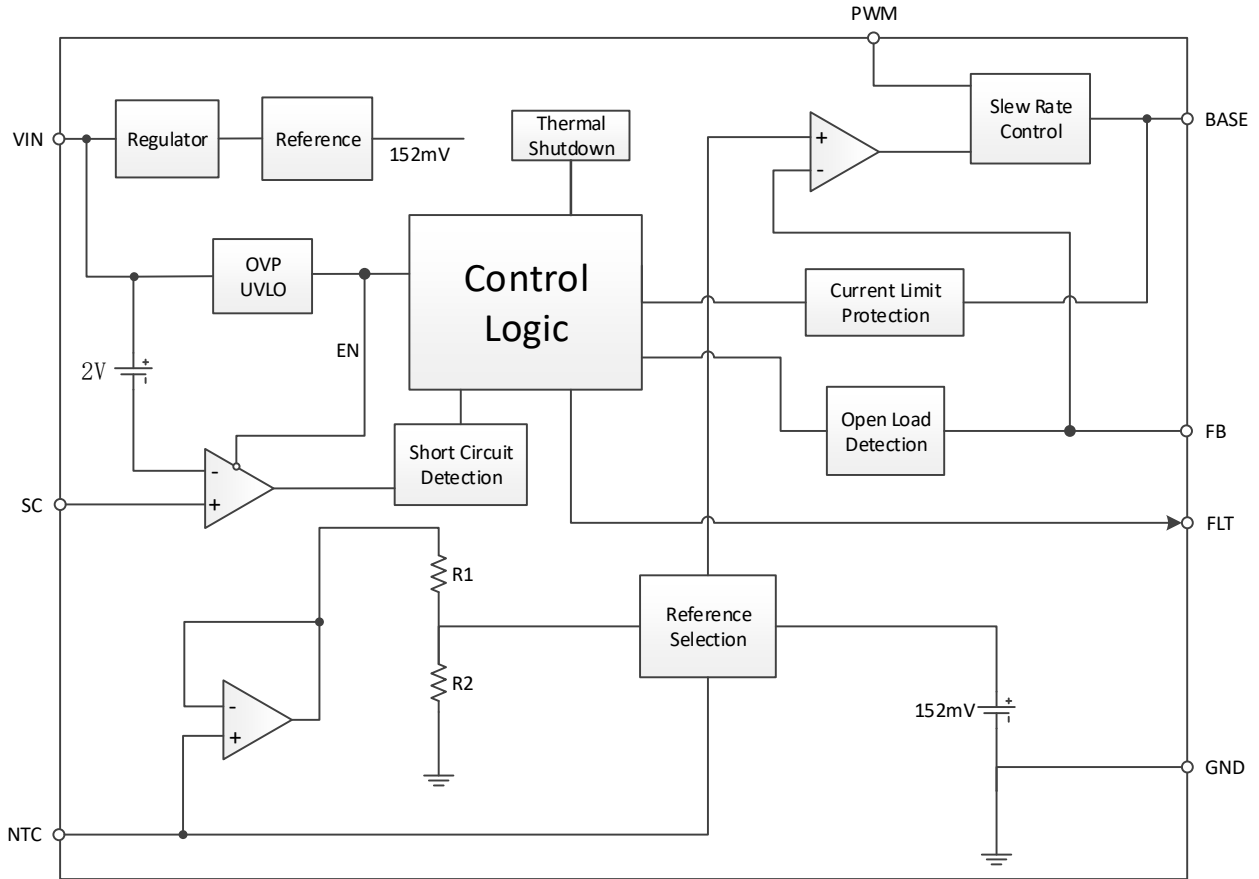



TABLE 1. FAULT HANDLING TABLE

Fault	Fault Memory	Sense Condition	Driver Condition During Fault	Driver Condition after Parameters Within Specified Limits	Output Fault Clear or Operation Restitution Requirement	Fault Reporting
Open Load (FLT active)	Latched off.	45 μ s FB < Vref/2 (76 mV) or Ibase > 22 mA 8.9 V < VIN < 20 V	Latched Off.	Latched Off.	Toggle PWM pin. VIN power down below UVLO.	FLT low to high
Open Load (FLT = GND)	No effect.	n/a	No effect.	No effect.	n/a	n/a
Short Circuit to VIN (FLT active)	Latched off.	23 μ s VIN - SC < 2 V VIN > 8.9 V	Latched Off.	Latched Off.	Toggle PWM pin. VIN power down below UVLO.	FLT low to high
Short Circuit to VIN (FLT= GND)	Latched off.	23 μ s VIN - SC < 2 V VIN > 8.9 V	Latched Off.	Latched Off.	Toggle PWM pin. VIN power down below UVLO.	n/a
Under Voltage Lockout	Driver Off	VIN < 4 V	Driver Off	Driver back on.	VIN > 4 V minus 200mV hysteresis.	n/a
Over Voltage	Output Current Reduced	Threshold 1 VIN > 20 V Threshold 2 VIN > 32 V	Reduced output current (FB Regulation Voltage)	Driver back to normal operation.	VIN < threshold minus 700 mv hysteresis.	n/a
Thermal Shutdown (FLT active)	Latched off.	23 μ s TJ > 165°C	Latched Off.	Latched Off.	Die temperature below shutdown hysteresis	FLT low to high
Thermal Shutdown (FLT=GND)	Latched off.	23 μ s TJ > 165°C	Latched Off.	Latched Off.	Die temperature below shutdown hysteresis	n/a

NOTE: All specified voltages, currents, and times refer to typical value.

OPERATING DESCRIPTION

GENERAL

The PT16976 device provides low-side current drive via an external bipolar transistor. The low voltage (152 mV) current sense threshold allows for maximum dropout voltage in the system. Dimming is performed using the dedicated PWM pin on the controller. Average output current is directly related to the intensity of the LED (or LED string).

OUTPUT DRIVE

Figure 1 shows the typical output drive configuration. A feedback loop regulates the current through the external LED. U1 monitors the voltage across the external sense resistor (R1). When the voltage exceeds the 152 mV reference, the output of U1 goes from high to low sending a signal the buffer (U2) decreasing the base drive to the external transistor (BCP56). For loads above 150 mA, a PZT651 device (replacing the BCP56) is recommended for stable operation. Normal operation includes a substantial voltage drop across the three LEDs limiting the power dissipation across the BCP56 transistor. Care must be taken when reducing the number of LEDs in the LED string for power considerations in the BCP56 and the Under Voltage Lockout performance.

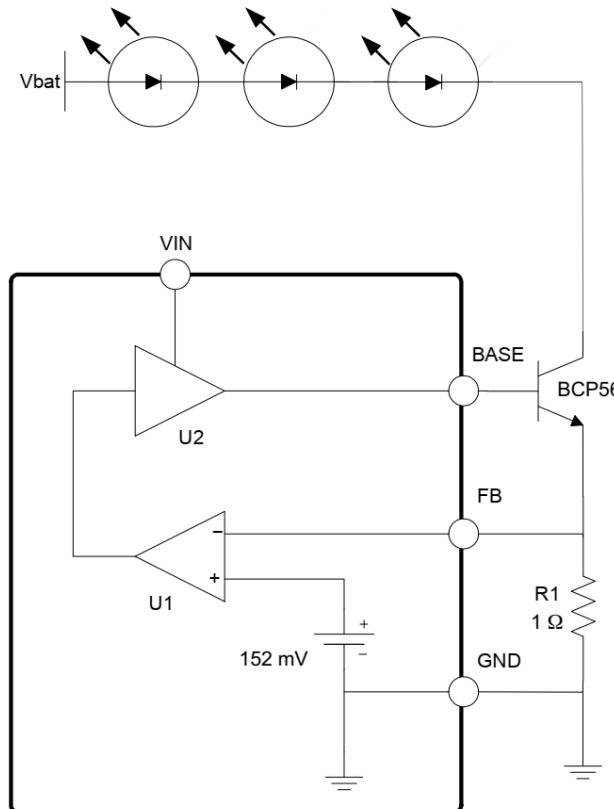

Figure 1. Output Drive Configuration

OPEN LOAD DETECTION

Faulted output strings due to open load conditions sometimes require the complete shutdown of illumination within an automotive rear lighting system. The PT16976 provides that feature option.

There are two open load detections schemes in the PT16976. These are OR conditions.

1. In normal regulation, the controller monitors the FB voltage (typ 152 mV). When this voltage falls by 50% (to typ 76 mV), an open circuit is detected and a current starts to charge FLT to flag open load, once FLT voltage crosses the output deactivation threshold the driver is switched off resulting in a latched off-state. When regulating via the NTC pin, the open load detection threshold is $V_{NTC}/20$.
2. During open load, the base current increases to try and satisfy the regulation loop. Internal circuitry monitors the base current. When the Base Current Drive reaches the Output Source Current (typ 22 mA) threshold, an open circuit is flagged and the driver is latched off.

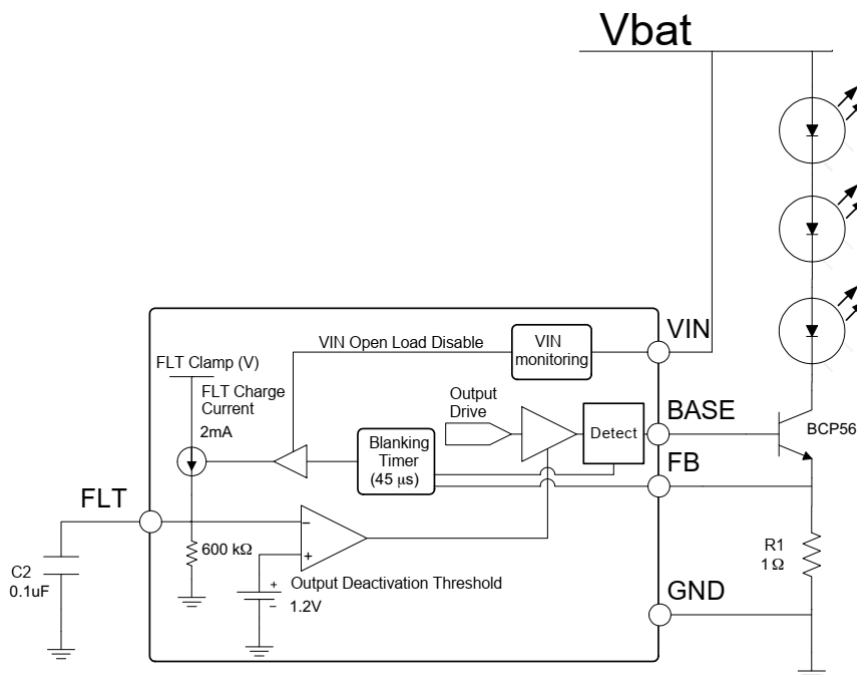

Figure 2. Open Load Detection

Table 2. OPEN LOAD DETECTION

Open Load (VIN > Open Load Disable Threshold)	FLT	BASE
No Open Load	Normal Operation (with FLT capacitor) (held low)	Regulation
No Open Load	Grounded	Regulation
FB ≤ 1/2 regulation	FLT starts charging (with FLT capacitor)	Held low via internal pull-down resistor after time-out.
BASE Current > 22 mA [typ]	FLT starts charging (with FLT capacitor)	Held low via internal pull-down resistor after time-out.
FB ≤ 1/2 regulation	Grounded	Regulation
BASE Current > 22 mA [typ]	Grounded	Regulation

When an open load is detected, the output turns off, and can be turned back on again by a toggle of the PWM pin or a power down of the supply (VIN).

If the open load feature is not used, FLT should be tied to GND. Grounding FLT disables open load detection. Short circuit detection and thermal shutdown functions remain active but are not reported externally. The BASE pin is actively held low in this case.

MULTIPLE STRING OPEN LOAD CONSIDERATION

In multi-string applications with high-beta transistors, the feedback voltage from individual strings is averaged, so one defective LED string does not always lead to the open load detection.

One of the ways to improve the open load detection capability is more precise external BASE current limitation. An example of the circuit with one extra resistor and PNP bipolar is shown in Figure 3.

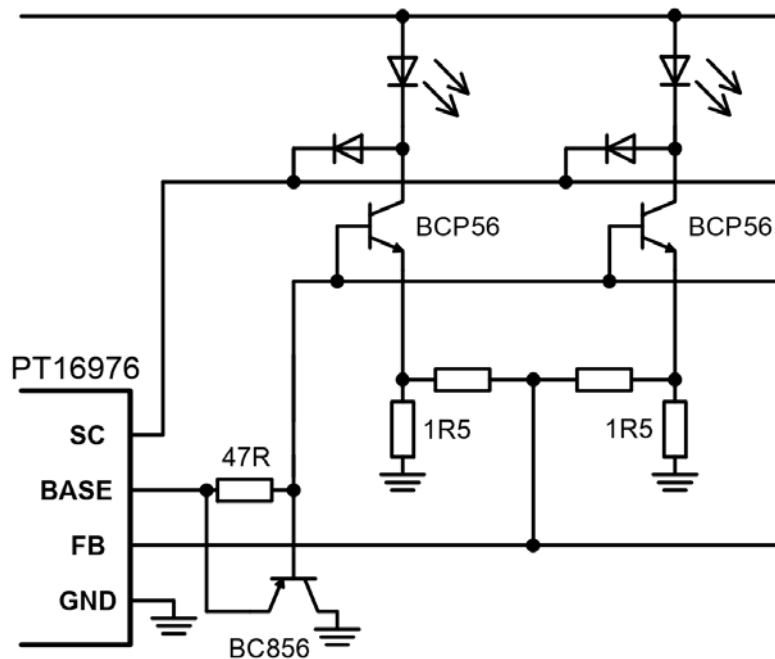

Figure 3. Improved Open Load Detection for Multiple Strings

SYSTEM VOLTAGE AND OVERVOLTAGE FOLD-BACK

In low voltage system operation, the detection of open loads is inactive below $V_{IN} = \text{typ } 8.9 \text{ V}$ (Open Load Disable voltage). There is also an upper limitation. The current roll off feature of the part resets the loop at a lower reference voltage and consequential lower current for V_{IN} above the Overvoltage Fold-back threshold on V_{IN} , (typ 20 V). The open load Detection circuitry is inactive for V_{IN} above this Overvoltage Fold-back threshold voltage.

OPEN LOAD TIMING

The timing for open load detection is programmed using the FLT pin. The PT16976 controller regulates a 152 mV reference point (Figure 2 on the feedback pin (FB)). When the voltage decreases (half of the FB Regulation Voltage) or the base current reaches the internal 22 mA (typ) limit for 45 μs , the timer associated with the FLT pin starts by charging the capacitor with a 2 mA current source. When the voltage on FLT exceeds the output Deactivation Threshold (typ 1.2 V), the BASE pin is pulled low and is held low by an internal pulldown resistor.

A 45 μs blanking time during power up ensures there is enough time for power-up to eliminate false open-load detections. The slow FLT discharge load (typ 600 k Ω) and resultant long time to restart LED drive eliminates flickering effects.

FLT INTERFACE

Figure 4 shows an open-drain logic level FET serving as a buffer to the microprocessor. Figure 5 shows the multiple IC implementation of open load detection which require all channels to latch-off with an open load condition. An open load condition will be reported back to the microprocessor regardless of which channel it occurs on.

The PT16976 controller uses a feature which allows any channel to charge the FLT capacitor due to its definition at a charge current value much higher than the discharge value. Additional PT16976 controllers may share the same common FLT capacitors in systems requiring multiple controllers.

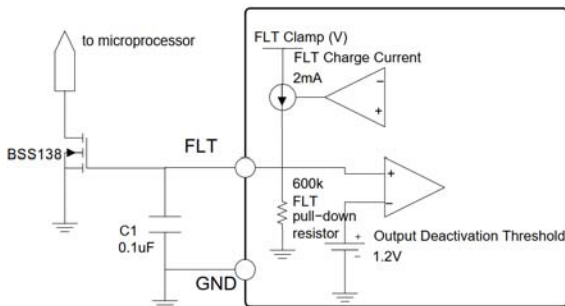

Figure 4. FLT Output Interface to Microprocessor

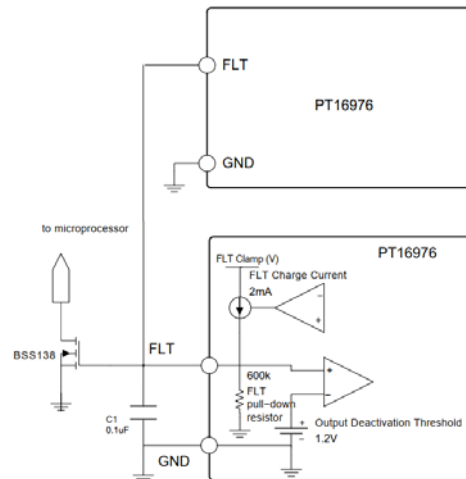

Figure 5. Multiple IC implementation of Open Load Detection

FLT pin reports three fault conditions (by going high) all of which force the output off.

- Open Circuit (latched)
- Short Circuit (latched)
- Thermal Shutdown (thermal hysteresis)

Latched off conditions can be reinitiated by a toggle of the PWM pin or a power down of the supply (VIN).

TEMPERATURE COMPENSATION

The PT16976 device typically operates the output current without Temperature Coefficient. The NTC (Negative Temperature Coefficient) pin provides an alternative for an output current which degrades with temperature as defined by the designer's external components.

When a negative temperature coefficient output current is desired to compensate for effects of external LED illumination, the setup shown in Figure 6 will provide the function. On the NTC pin, a comparator detects when the voltage is higher than typ 220 mV, and this voltage is used to provide the feedback reference voltage for the current feedback regulation loop.

The zener provides a reference voltage for the negative temperature coefficient NTC device through an external divider. Be careful of your choice of the zener diode as the temperature coefficients of the devices have a wide variation with the low voltage zeners having a high negative temperature coefficient and the high voltage zeners having a positive temperature coefficient. The regulation loop voltage on NTC should be sufficiently higher than the 220 mV reference voltage to avoid interactions. A typical regulation voltage of 1.6 V is suggested.

The overall tolerance specification for the NTC functionality is broken down into two components.

1. Absolute error. A $\pm 2\%$ tolerance is attributed to the expected value as a result of internal circuitry (most predominantly the 1/10 resistor divider).
2. Reference error. A $\pm 7\text{mV}$ offset mismatch in the circuitry referenced to FB.

This provides a part capability of $(V_{NTC}/10) \times 0.98 - 7\text{mV} < V(\text{FB}) < (V_{NTC}/10) \times 1.02 + 7\text{mV}$.

In addition to the temperature coefficient of the zener diode (D1), a PTC resistor (R2) can be used to enhance the effect of the overall negative temperature coefficient. A positive temperature coefficient resistor at the top of the resistor divider

creates a negative temperature coefficient at the resistor divider output. Alternatively, a negative temperature coefficient resistor for R3 would have the same effect.

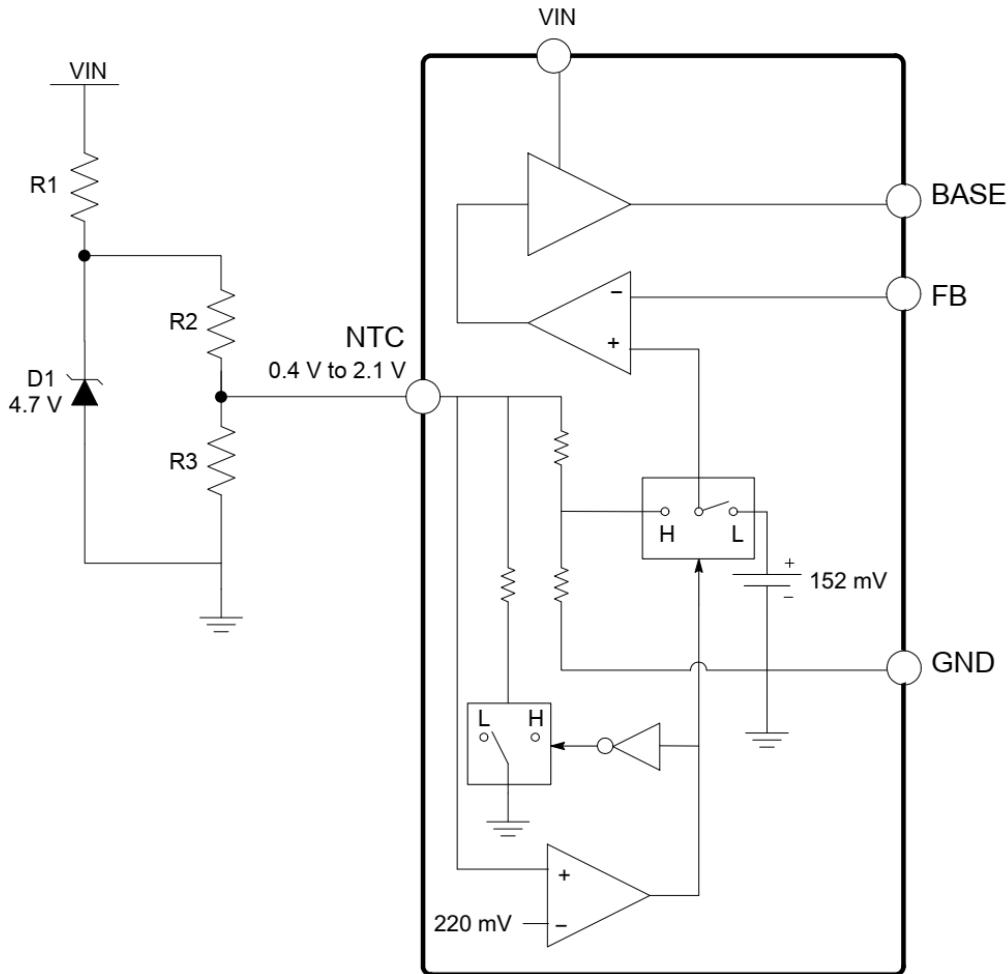

Figure 6. Negative Temperature Compensation Operation

SHORT CIRCUIT DETECTION

The short circuit (SC) pin of the controller is used as an input to detect a fault when LEDs are shorted (the cathode of LED string is shorted to the VIN). The threshold voltage detection is referenced 2.0 volts down from the VIN pin. A voltage of less than 2.0 volts between VIN and SC will latch the device off. The PWM pin must be toggled or UVLO event must occur to reinitiate a turn-on. The detection time for this event is swift to protect the external transistor. To maintain operation during transient events down to 4.5 V, the short circuit detection circuitry is inactive below VIN = typ 8.9 V. (the same Open Load Disable voltage as used to disable Open load detection). Otherwise false short circuit events could be falsely triggered due to non-conduction of the external LEDs during transients.

Figure 7 shows a short circuit event modeled as a switch (S1). The comparator connected between VIN and SC is referenced to a voltage 2.0 V down from VIN. A detection voltage less than 2.0V will toggle a signal from the comparator to the output drive buffer turning off output drive (BASE) to the external bipolar transistor. An initial blanking time of 23 μ s is used during turn-on of the device to ignore false detections. This is beneficial during normal operation and when the device is used without a microprocessor input (PWM) interface as in Figure 7.

Switching off the Base-driver in case of SC, will also make the FLT charge active, indicating the error to the microprocessor.

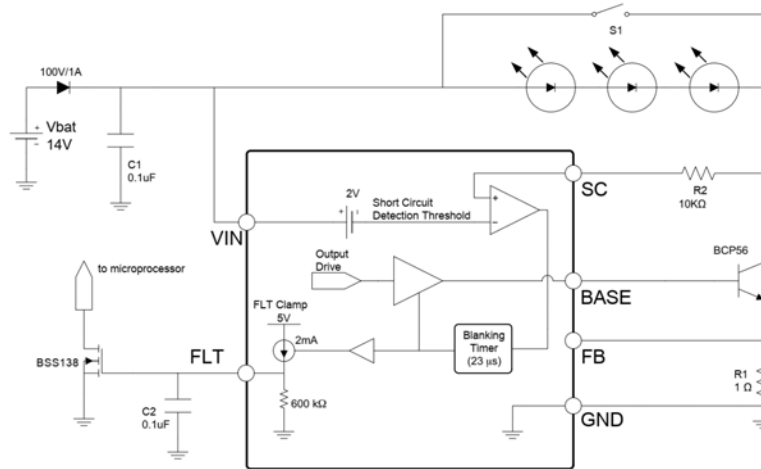

Figure 7. Short Circuit Detection

When having multiple channels an isolation might be needed to provide the appropriate voltage back to the SC pin during short circuit. Figure 8 shows how external diodes can provide this feature. Interfacing the short circuit detection for multiple channels with one PT16976 driver system is done easily using diodes or a diode resistor combination depending on your system requirements.

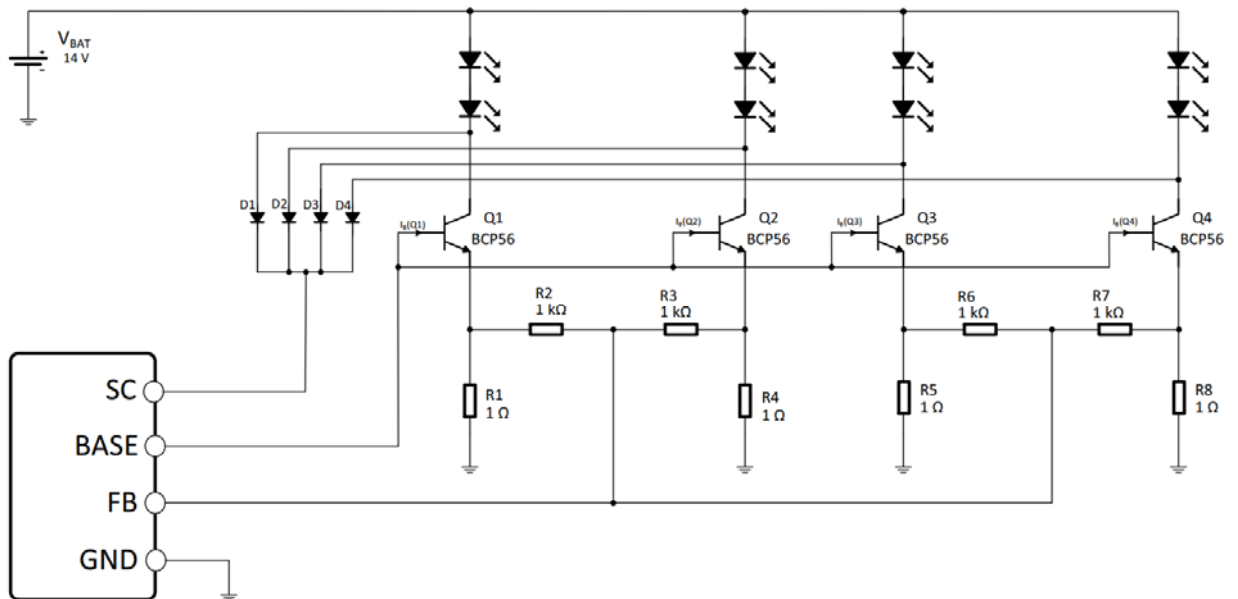

Figure 8. Short Circuit Detection with 4 or more Channels

THERMAL SHUTDOWN

The thermal shut down circuit checks the internal junction temperature of the device. When the internal temperature rises above the Thermal shutdown threshold for greater than the thermal shutdown filter time (23 μ s [typ]) the device is switched off. The filter is implemented to achieve a clean detection.

Switching off the Base-driver in case of TSD, will also make the FLT charge active, indicating the error to the microprocessor.

ABSOLUTE MAXIMUM RATINGS

	Value	Unit
Supply Voltage (VIN) DC Peak Transient	-0.3 to 50 50	V
High Voltage Pins (PWM, SC)	-0.3 to (VIN + 0.3)	V
Low Voltage Pins (FB, NTC)	-0.3 to 3.6	V
Low Voltage Pin (BASE)	-0.3 to 3.6 or VIN + 0.6 whichever is lower	V
Fault Input / Output (FLT)	-0.3 to 6	V
Junction Temperature, TJ	-40 to 150	°C

Stresses exceeding those listed in the Maximum Ratings table may damage the device. If any of these limits are exceeded, device functionality should not be assumed, damage may occur and reliability may be affected.

ATTRIBUTES

Characteristic	Value
ESD Capability	
Human Body Model (HBM)	± 2000V
Charge Device Mode (CDM)	± 1000 V
Machine Mode (MM)	± 250 V
Storage Temperature	-55 to 150°C
Moisture Sensitivity	MSL 3



ELECTRICAL CHARACTERISTICS

(4.5 V < VIN < 18 V, C_{FLT} = 0.1 μF, R1 = 1Ω, Transistor NPN = BCP56, -40°C ≤ TJ ≤ 150°C, unless otherwise specified.)

Parameter	Test Condition	Min	Typ	Max	Unit
GENERAL PARAMETERS					
Supply Current in normal condition	VIN = 14 V, PWM = 0	-	20	100	μA
	VIN = 14 V, PWM = High Base current subtracted	-	2.0	5.0	mA
Supply Current in fault condition	VIN = 14 V, PWM = High V _{FLT} ≥ FLT Clamp (5.0 V typ.)	-	1	3	mA
Under Voltage Lockout	VIN rising	3.6	4	4.4	V
Under Voltage Lockout Hysteresis		-	200	-	mV
Base Current Drive					
Output Source Current	BASE = 1 V, FB = 0 V	15	22	30	mA
Output Pull-Down Resistance	PWM = 0 V, BASE = 1 V, FB = 0 V	0.5	1	2	kΩ
Unity Gain Bandwidth		-	100	-	kHz
Amplifier Trans-conductance		-	30	-	mA/mV
Programming					
FB Regulation Voltage	Under Voltage Lockout < VIN < Over Voltage Fold, Back Threshold 1	142	152	162	mV
	VIN > Over Voltage Fold Back Threshold 1	54	76	100	
	VIN > Over Voltage Fold Back Threshold 2	22	38	50	
VIN Overvoltage Fold Back Threshold 1		19	20	21	V
VIN Overvoltage Fold Back Threshold 1 Hysteresis		-	700	-	mV
VIN Overvoltage Fold Back Threshold 2		30.5	32	33.5	V
VIN Overvoltage Fold Back Threshold 2 Hysteresis		-	700	-	mV
Open Load Timing					
VIN Open Load Disable Threshold	VIN falling	8.0	8.9	9.04	V
FLT Charge Current	PWM = 5 V, FB = 0 V, VIN = 14 V	1	2	3	mA
FLT Pull Down Resistor		400	600	800	kΩ
FLT Threshold (Output Deactivation Threshold)		1	1.2	1.4	V
FLT Clamp	VIN = 18 V, PWM = 5 V, Charge Current activated Above this clamp voltage Charge current rolls off to 0	4	5	6	V
Short Circuit					
Short Circuit Detection Threshold		VIN - 1.7	VIN - 2	VIN - 2.3	V
Short Circuit Output Current	Current out of the SC pin	-	8	16	μA
PWM					
Input High Threshold		-	1.5	2	V
Input Low Threshold		0.7	1	-	V
Hysteresis		-	0.5	-	V
Input Pull-down Resistor		30	120	190	kΩ
Temperature Compensation					
Regulation Offset	0.4 V < NTC < 2.1 V, VIN = 14 V	-2	-	+2	%



Parameter	Test Condition	Min	Typ	Max	Unit
(referenced to FB)		-7	-	+7	mV
NTC Attenuation	0.4 V < NTC < 2.1 V	-	1/10	-	
NTC Input Pull-down Resistor	NTC = 150 mV (low impedance)	15	22	31	kΩ
	NTC = 400 mV (high impedance)	-	1	-	MΩ
NTC Detection Level		170	220	300	mV
AC CHARACTERISTICS					
LED Current rise time	10% / 90% criterion, PWM rising	1	2.5	7.5	μs
LED Current fall time	90% / 10% criterion, PWM falling	1	2.5	7.5	μs
Propagation Delay PWM rising to Iout	50% criterion	-	5	15	μs
Propagation Delay PWM falling to Iout	50% criterion	-	2	15	μs
PWM Propagation Delay Delta	(Falling time) - (Rising time)	-	-	4	μs
Delay Time VIN to BASE		-	4	9	μs
Open Load Blanking Delay	FLT capacitor charge time not included	25	45	70	μs
Short Circuit Blanking Time		10	23	36	μs
Power-Up Blanking Time		10	23	36	μs
THERMAL LIMIT					
Thermal Shutdown		150	165	180	°C
Thermal Hysteresis		-	25	-	°C
Thermal Shutdown Delay		10	23	36	μs

DESIGN GUIDE

DIRECT DRIVE WITHOUT DIRECT BATTERY CONNECTION

Some applications may not allow for a direct connection of VIN to the battery voltage. These applications require a connection with a P-channel MOSFET. Figure 9 highlights this setup.

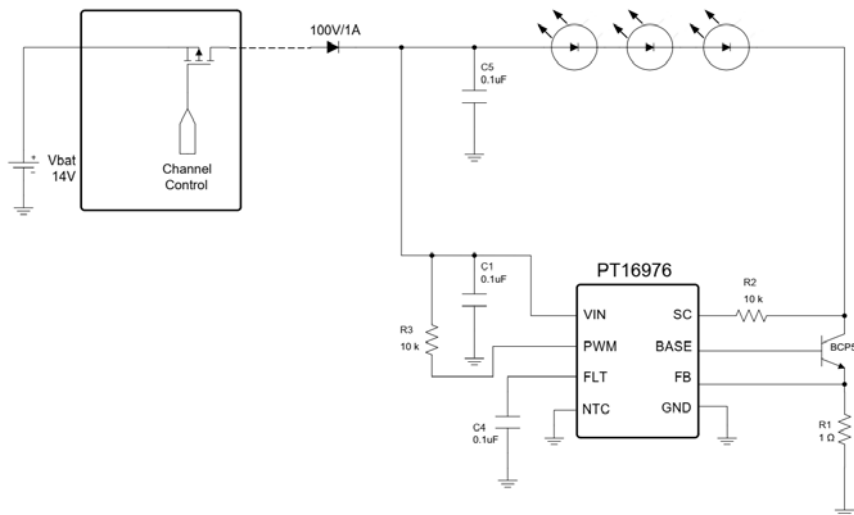

Figure 9. External Power-on control

HIGH EFFICIENCY APPLICATION

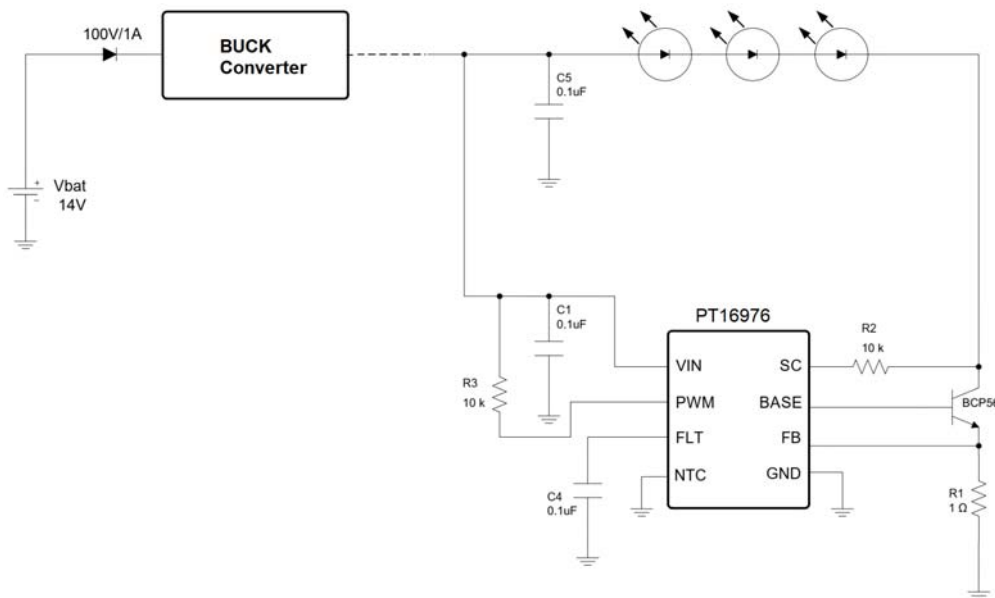

Figure 10. High Efficiency Application

In two or three LEDs series connected application, the forward voltage of LED string is 6~9V, the redundant voltage drops across the NPN transistor and cause the large power dissipation. To improve the system efficiency, a step-down converter can be inserted between battery and PT16976. The output voltage of the converter is set to close the forward voltage of LED string, the power dissipation of the NPN transistor can be limit.

STOP/TAIL LIGHT APPLICATION

Automotive applications have a need to drive the RCL (Rear Combination Light). Combining the PT16976 with a Timer or PWM Generator accomplishes that task. Figure 11 shows the interface of STOP/TAIL light using additional diodes. The STOP input signal provides a signal to the PT16976 which will provide a 100% duty cycle output to the LED strings when STOP is high. When TAIL input signal is high, a modulated duty cycle input is provided to the PWM input.

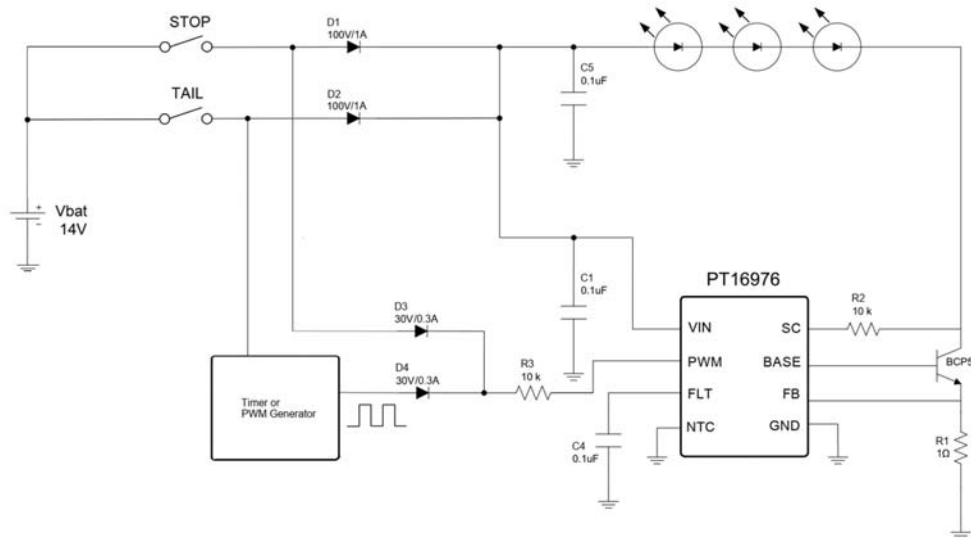

Figure 11. Stoplight / Taillight Application

OTHERS

Figure 12: Application Diagram with no microprocessor. A resistor pull-up from PWM to VIN illustrates how the device can be used as a standalone LED driver without using a microprocessor to drive the PWM input.

Figure 13 along with Figure 14 and Figure 15 highlight the use of the PT16976 device with multiple strings connected to a common drive BASE pin and using external resistors to tie additional strings to a common feedback point (FB). The FB pin will maintain regulation with the FB pin at 152 mV. R1 is used to limit current in the event of an open circuit on one of the strings.

Figure 14: Open Circuit. It shows the change in BASE drive which occurs with an open circuit in one of the strings. The drive current out of BASE changes from $(I_b(Q1) + I_b(Q2))$ to $(I_b(Q1) + I_c(Q2))$ as regulation will try to maintain in the loop to get 152 mV on FB.

Figure 15 shows the equivalent circuit when an open load occurs.

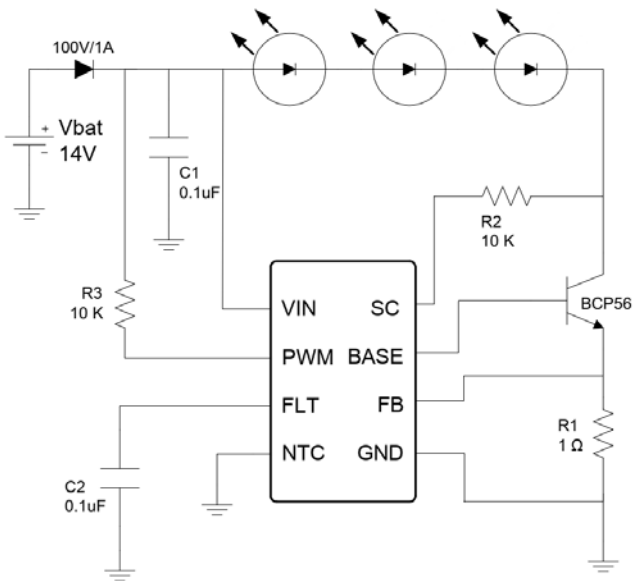

Figure 12. Application Diagram with No Microprocessor

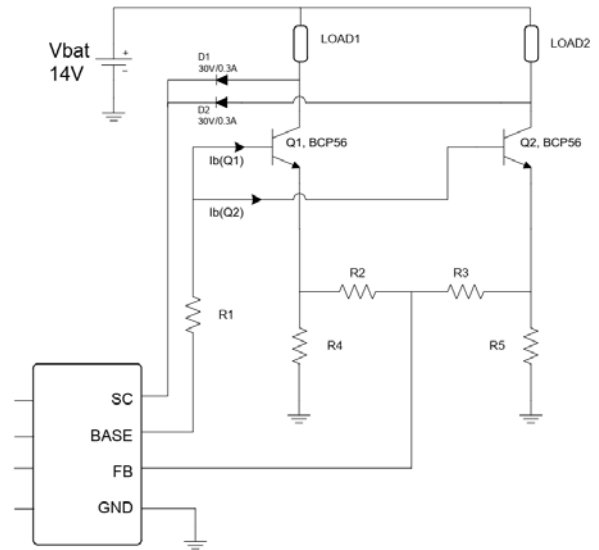

Figure 13. Driving Multiple Strings

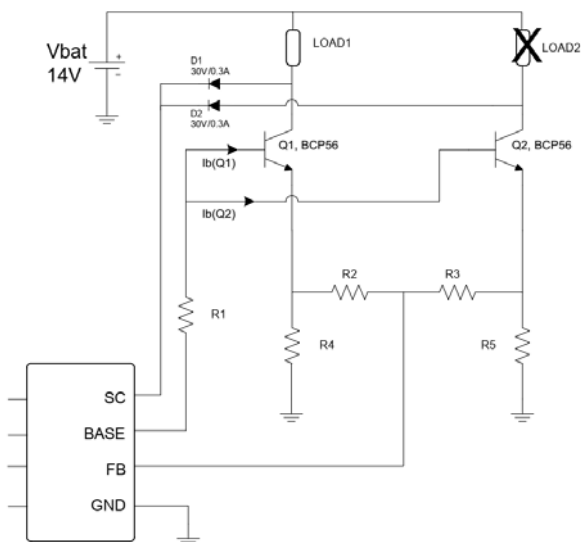

Figure 14. Open Circuit

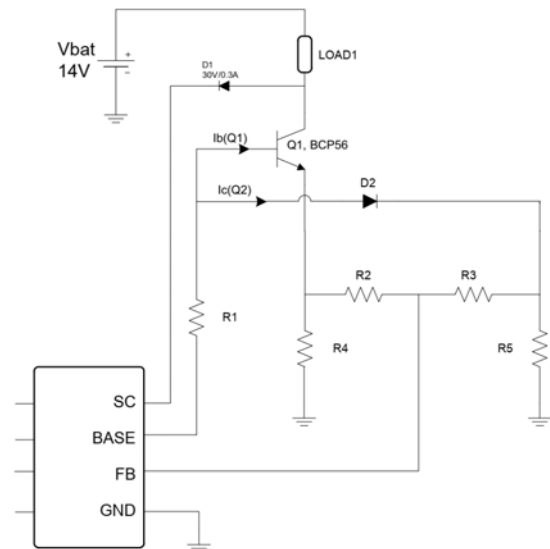
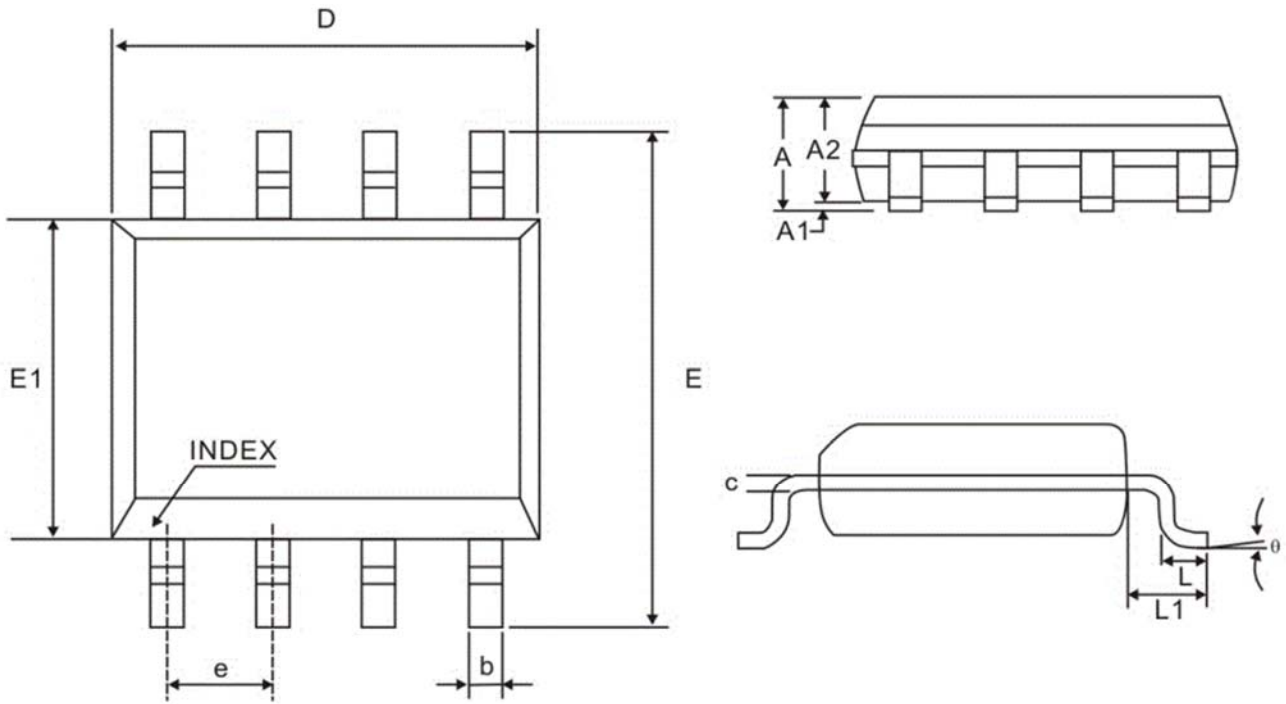

Figure 15. Open Circuit Equivalent



PACKAGE INFORMATION

SOP8



SYMBOL	MILLIMETER		
	MIN	NOM	MAX
A	-	-	1.75
A1	0.10	-	0.25
A2	1.25	-	-
b	0.31	-	0.51
c	0.10	-	0.25
D	4.90 BSC		
E	6.00 BSC		
E1	3.90 BSC		
e	1.27 BSC		
L	0.40	-	1.27
L1	1.04 REF		
θ	0°	-	8°

Note: 1. Refer JEDEC MS-012 AA
2. Unit: millimeter



IMPORTANT NOTICE

Princeton Technology Corporation (PTC) reserves the right to make corrections, modifications, enhancements, improvements, and other changes to its products and to discontinue any product without notice at any time.

PTC cannot assume responsibility for use of any circuitry other than circuitry entirely embodied in a PTC product. No circuit patent licenses are implied.

Princeton Technology Corp.
2F, 233-1, Baociao Road,
Sindian Dist., New Taipei City 23145, Taiwan
Tel: 886-2-66296288
Fax: 886-2-29174598
<http://www.princeton.com.tw>