

DESCRIPTION

PT16977 is a three-channel linear constant current LED driver with analog and PWM dimming control, and each channel has independent PWM dimming. The driver designed to accommodate a slow input voltage of 0.5 V/min with no issues. Its full-diagnostic and built-in protection capabilities make it a suitable choice for variable-intensity LED lighting applications up to the medium-power range.

The device is available in a HTSSOP16 package, and the operating junction temperature range is -40°C to 150°C .

APPLICATIONS

- Rear Combination Light (RCL)
- Position Light
- Turn Light
- Stop or Tail Light
- Fog Light
- General linear LED Light

FEATURES

- Automotive AEC-Q100, Grade 1 (-40°C ~ $+125^{\circ}\text{C}$) Qualified
- Input voltage range: 5 V–40 V
- Single resistor set for output current
 - Max. Current: 150 mA per Channel
 - Channel Accuracy: $\pm 2\%$ @ $I_{(\text{IOUT}_x)} > 30\text{mA}$
 - Device Accuracy: $\pm 3\%$ @ $I_{(\text{IOUT}_x)} > 30\text{mA}$
 - Max. Current: 450 mA in parallel operation mode
- Parallel outputs for higher current using multiple ICs or multiple channels of a single IC
- Low dropout voltage: 800mV@150mA per channel
- Independent PWM dimming per channel
- Open and shorted LED detection with deglitch timer
- LED-string voltage feedback per channel for single-LED short detection
- Fault pin for open, short, and thermal shutdown failure reporting, allowing parallel bus connection up to 15 Devices
- Separate fault pin for single-LED short failure

TYPICAL APPLICATION

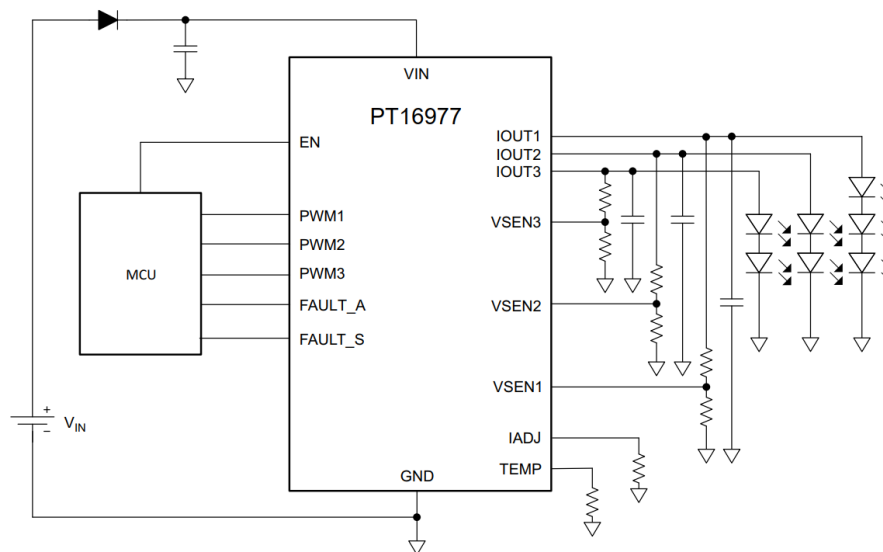

1 ORDER INFORMATION

Part Number	Package	Top Code
PT16977-HT	HTSSOP 16pins	PT16977-HT

2 PIN CONFIGURATION

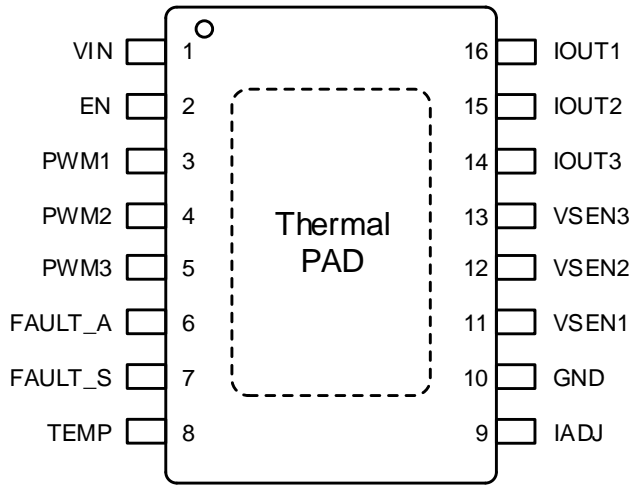

3 PIN DESCRIPTION

PIN Name	PIN No.	I/O	DESCRIPTION
VIN	1	--	Supply voltage input.
EN	2	I	Enable and shut down. Setting input signal to logic-low, turn off the device.
PWM1	3	I	PWM input and channel ON or OFF. Tie to GND if this channel is not used.
PWM2	4	I	
PWM3	5	I	
FAULT_A	6	I/O	Fault pin. Leave floating if not used.
FAULT_S	7	I/O	Single-LED short fault. Leave floating if not used.
TEMP	8	I/O	Temperature fold-back threshold program. Tie to GND if not used.
IADJ	9	O	Reference resistor pin for normal current setting.
GND	10	--	Ground.
VSEN1	11	I	String voltage sense. Connect to IOUT1 if not used.
VSEN2	12	I	String voltage sense. Connect to IOUT2 if not used.
VSEN3	13	I	String voltage sense. Connect to IOUT3 if not used.
IOUT3	14	O	Current output pin. Connect to VSNS3 if not used.
IOUT2	15	O	Current output pin. Connect to VSNS2 if not used.
IOUT1	16	O	Current output pin. Connect to VSNS1 if not used.

4 FUNCTIONAL BLOCK DIAGRAM

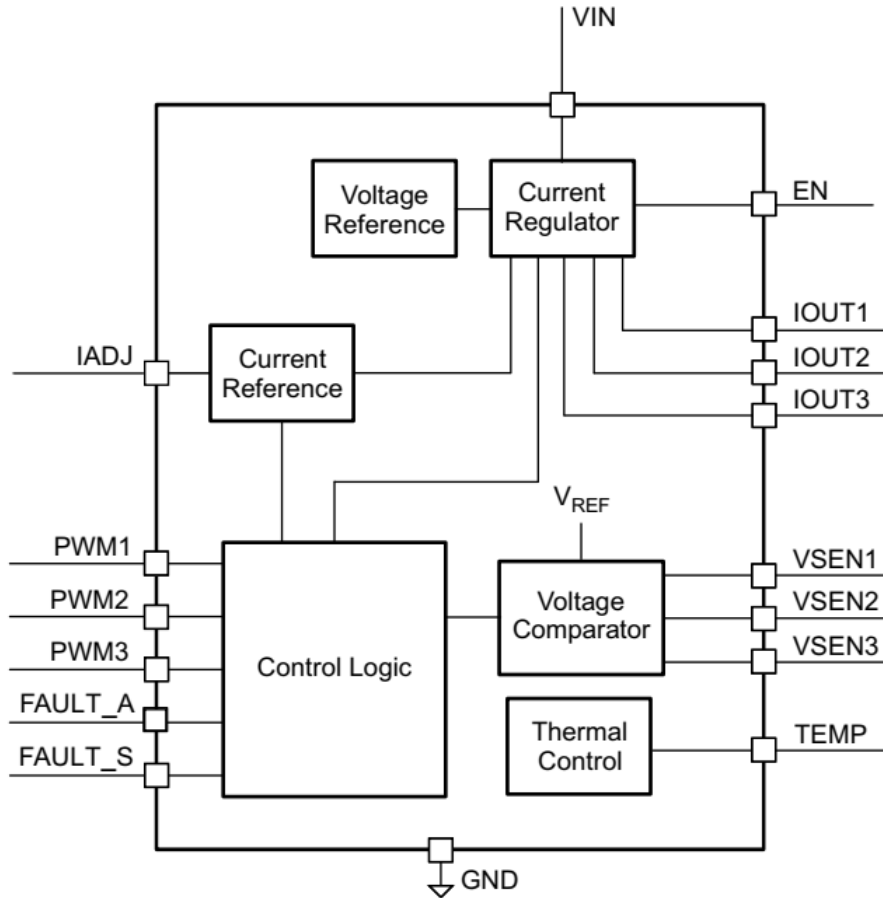

5 FUNCTION DESCRIPTION

5.1 OVERVIEW

PT16977 is a three-channel constant-current regulator with individual PWM dimming, designed for high brightness LEDs in automotive lighting applications. Each channel has up to 150mA current capability, giving a combined 450mA current capability when paralleled. The device provides excellent current matching between channels and devices. A high-side current source allows LED common-cathode connections. The advanced control loop allows high accuracy between channels, even when different numbers of LEDs are connected on the output. Use of a separate PWM channel dims or disables each channel.

The device monitors fault conditions on the output and reports its status on the FAULT_A and FAULT_S pins. It features single-short-circuited-LED detection, output short-to-ground detection, open-load detection, and thermal shutdown. Two separate fault pins allow maximum flexibility of fault-mode reporting to the MCU in case of an error. In case there is no MCU, one can connect multiple ICs in a bus mode. Integrated thermal fold-back protects the devices from thermal shutdown by reducing the output current linearly when reaching a preset threshold. Use an external resistor to program the temperature fold-back threshold. Tying the TEMP pin to ground to disable the thermal fold-back function.

5.2 PWM CONTROL

The device features a separate PWM dimming control pin for each output channel. PWM inputs also function as shutdown pin when an output is unused. Tying PWM to ground disables the corresponding output. The PWM signal has a precise threshold, which one can use to define the start-up voltage of LED as an under-voltage lockout (UVLO) function with the divider resistor from the VIN pin.

5.3 FAULT DIAGNOSTICS

The device has two fault pins, FAULT_A and FAULT_S. FAULT_A is for general faults, such as short, open, and thermal shutdown. FAULT_S is a dedicated fault pin for single LED short failure. The dual pins allow maximum flexibility based on all requirements and application conditions. The device fault pins can be connected to an MCU for fault reporting. Both fault pins are open-drain transistors with a weak internal pull-up. Figure 1 shows the detailed fault timing diagram.

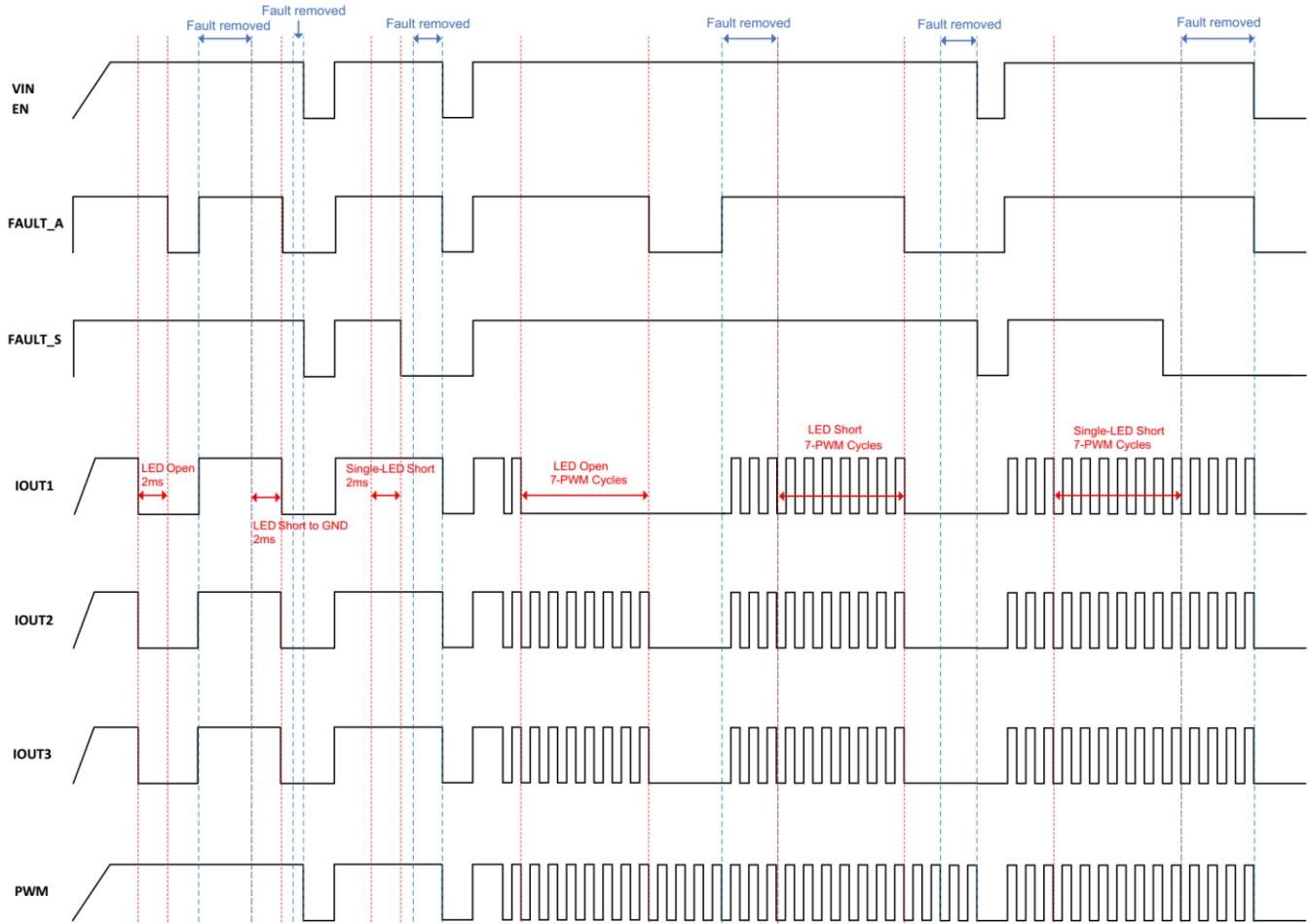

Figure 1 Detailed Timing Diagram (FAULT_A and FAULT_S floating)

In case there is no MCU, one can connect up to 15 PT16977 FAULT_A and FAULT_S pins together. When one or more devices have errors, the respective FAULT pins go low, pulling the connected FAULT bus down and shutting down all device outputs. Figure 2 shows the fault-line bus connection. The device releases the FAULT bus when external circuitry pulls the FAULT pin high, on toggling of the EN pin, or on a power cycle of the device. In case there is no MCU, only a power cycle clears the fault. Figure 3 shows the fault timing diagram when the FAULT_A and FAULT_S pins are connected together.

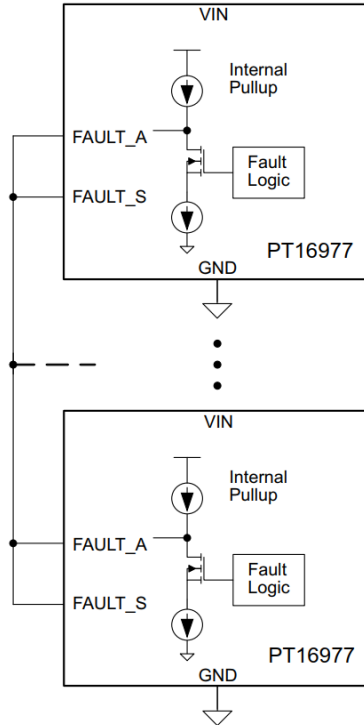

Figure 2 Fault-Line Bus Connection

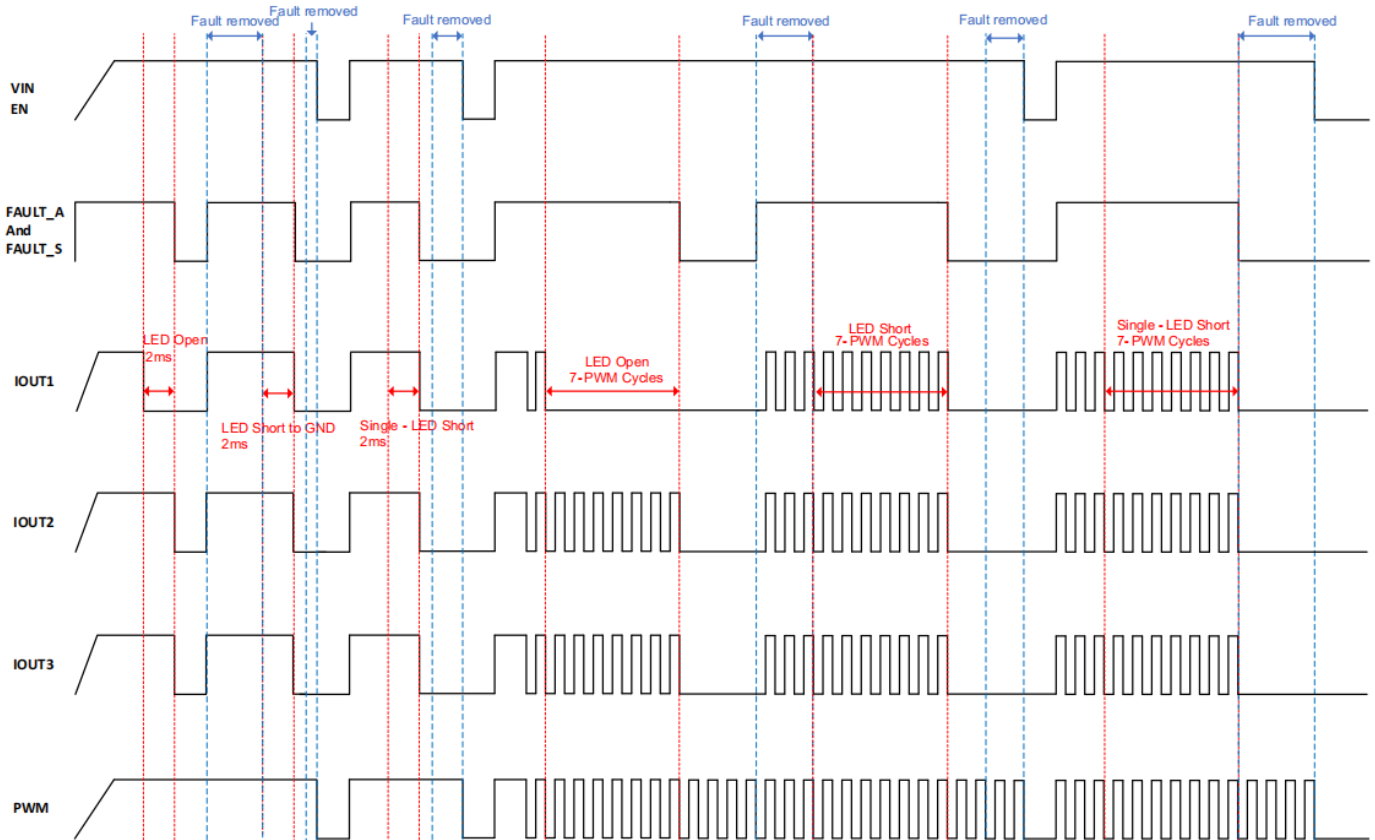

Figure 3 Detailed Timing Diagram

The following faults result in the FAULT_A or FAULT_S pin going low: thermal shutdown, open load, output short circuit, single LED short, and IADJ open or shorted. For thermal shutdown or LED open, release of the FAULT_A pin occurs when the thermal-shutdown or LED-open condition no longer exists. For other faults, the FAULT_A and FAULT_S pins stay low even if the condition does not exist. Clearing the faults requires a power cycle of the device.

5.4 LED CURRENT SETTING

Control of the three LED output channels is through separate linear current regulators. A common external resistor sets the current in each channel.

LED current can be calculated by Equation 1:

$$I_{OUTX} = \frac{V_{IADJ} \times K_I}{R_{IADJ}} \tag{1}$$

V_{IADJ} = Reference Voltage: 1.198 V (typ)

K_I = Ratio of I_(IOUTx) to reference current: 100(typ)

5.5 THERMAL FOLDBACK

The PT16977 integrates thermal shutdown protection to prevent the device from overheating. In addition, to prevent LEDs from flickering because of rapid thermal changes, the device includes a programmable thermal current-foldback feature to reduce power dissipation at high junction temperatures.

The device reduces the LED current as the junction temperature increases (see Figure 4). By mounting the device on the same thermal substrate as the LEDs, use of this feature can also limit the dissipation of the LEDs. As the junction temperature of the device increases, the device reduces the regulated current, reducing the dissipated power in the device and in the LEDs. The current reduction is from the 100% level at typically 2% of I(setting) per °C until the point at which the current drops to 50% of the full value.

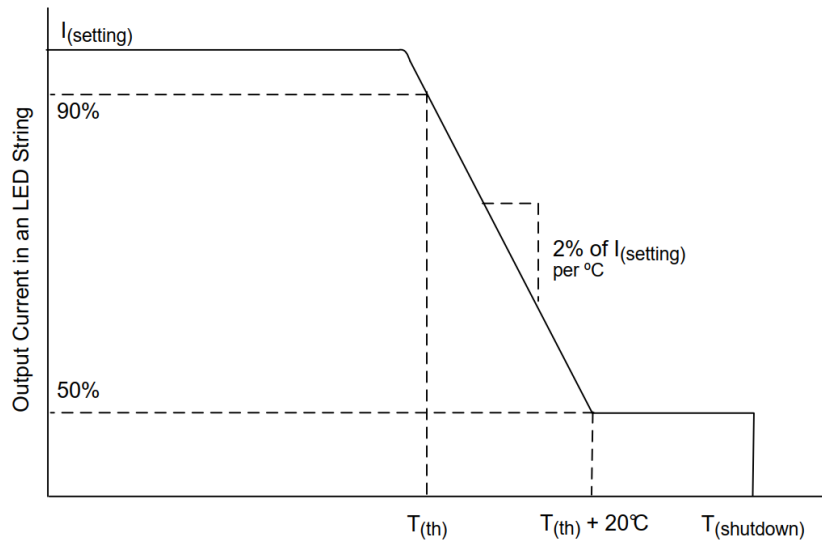

Figure 4 Thermal Foldback

Above this temperature, the current continues to decrease at a lower rate until the temperature reaches the over temperature shutdown threshold temperature, T_(shutdown). Changing the voltage on the TEMP pin adjusts the temperature at which the current reduction begins. With TEMP floating, the definition of thermal monitor activation temperature, T_(th), is the temperature at which the current reduction begins. The specification of T_(th) in the characteristics table is at the 90% current level. T_(th) increases as the voltage at the TEMP pin, V_(TEMP), declines and is defined as approximately:

$$T_{th} = 222.9 - 104 \times V_{TEMP} \tag{2}$$

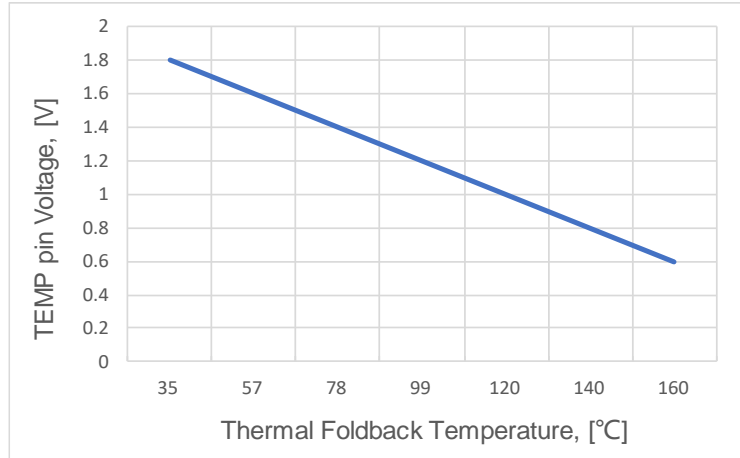

Figure 5 TEMP Pin Voltage vs Temperature

A resistor connected between TEMP and GND reduces $V_{(TEMP)}$ and increases $T_{(th)}$. A resistor connected between TEMP and a reference supply greater than 1 V increases $V_{(TEMP)}$ and reduces $T_{(th)}$. Figure 6 shows how the nominal value of the thermal-monitor activation temperature varies with the voltage at TEMP and with either a pulldown resistor to GND or with a pullup resistor to 3.3 V or 5 V

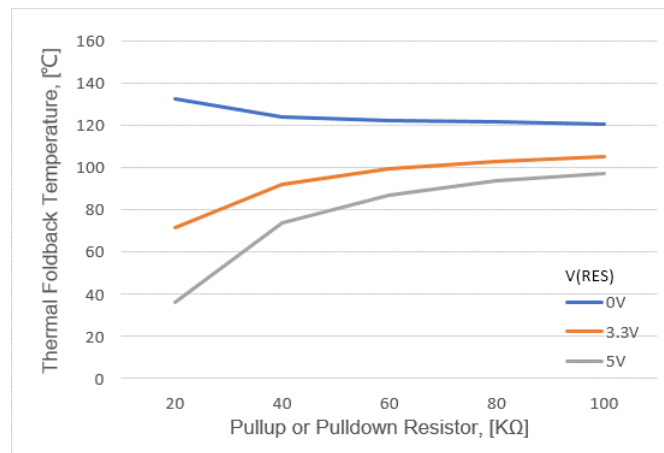

Figure 6 Pullup and Pulldown Resistors vs $T_{(th)}$

In extreme cases, if the junction temperature exceeds the over temperature limit, $T_{(shutdown)}$, the device disables all channels. Temperature monitoring continues, and channel reactivation occurs when the temperature drops below the threshold provided by the specified hysteresis.

Note the possibility of the PT16977 device transitioning rapidly between thermal shutdown and normal operation. This can happen if the thermal mass attached to the exposed thermal pad is small and $T_{(th)}$ is increased to close to the shutdown temperature. The period of oscillation depends on $T_{(th)}$, the dissipated power, the thermal mass of any heatsink present, and the ambient temperature.

5.6 OPEN LOAD DETECTION

Detection of an open-load condition occurs when the voltage across the channel, $V_{(VIN)} - V_{(IOUTx)}$, is less than the open-load detection voltage, $V_{(OLV)}$. When this condition is present for more than the open-load-detection deglitch (2 ms when PWM is 100% on or one PWM on-time is more than 2 ms, or seven continuous PWM duty cycles when in PWM dimming mode), the FAULT_A pin goes low, keeping the open channel on and turning the other channel off. With the FAULT_A pin tied high, all channels remain turned on. The channel recovers on removal of the open condition. Note that the device can detect an open load if the sum of the forward voltages of the LEDs in a string is close to or greater than the supply voltage on VIN.

5.7 SHORT CIRCUIT DETECTION

The PT16977 includes three internal comparators for LED forward-voltage measurement. With external resistor dividers, the device compares total LED forward voltage with the internal reference voltage. This feature enables the detection of one or more shorted LEDs. Any LED cathode or IOUTx pin shorted to ground results in a short circuit condition. The external resistor dividers control the detection-threshold-voltage setting. Figure 7 illustrates different short-circuit conditions.

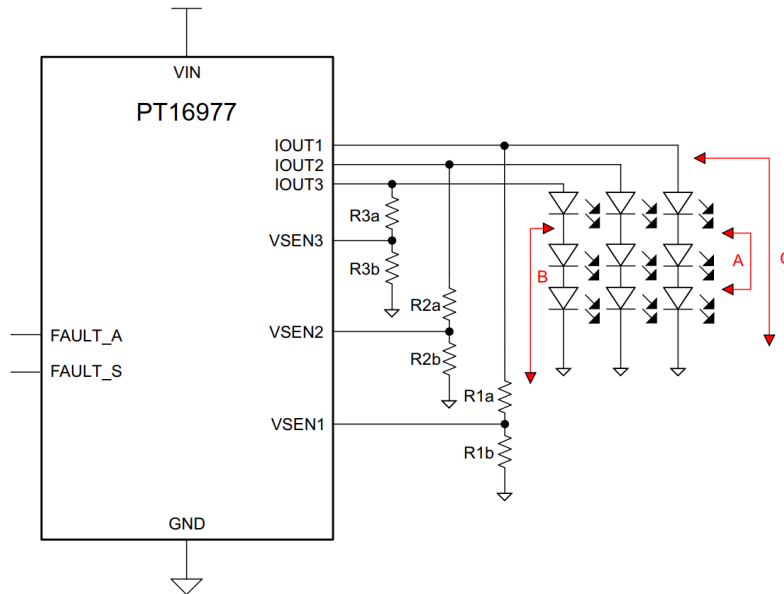

Figure 7 Short Circuit Conditions

A short in one or more LEDs in a string (A and B as Figure 7 illustrated) registers as only a single-LED short when $V(VIN) > 9\text{ V}$.

- The device reports the failure to the MCU. The faulted channel continues sourcing current until the MCU takes actions to turn off channels through the EN or PWMx pin.
- No MCU: with FAULT_S floating, no action results. With FAULT_S tied to FAULT_A, all output channels shut down together.

When an entire string of LEDs is shorted (C as Figure 7 illustrated), the device pulls FAULT_A low to shut down all channels. With the FAULT_A pin tied high, only the faulted channel turns off.

The triggering conditions for single LED short circuit fault can be calculated using the following formula:

$$(N - 1) \times V_{F(max)} < V_{SENx} \times R < N \times V_{F(min)}$$

3

- $V_{F(max)}$ – maximum forward voltage of LED used
- $V_{F(min)}$ – minimum forward voltage of LED used
- N – Number of LEDs used in a string
- R – resistor divider ratio $(R_{xa} + R_{xb}) / R_{xb}$
- $V_{(SENx)}$ – internal reference voltage of comparators

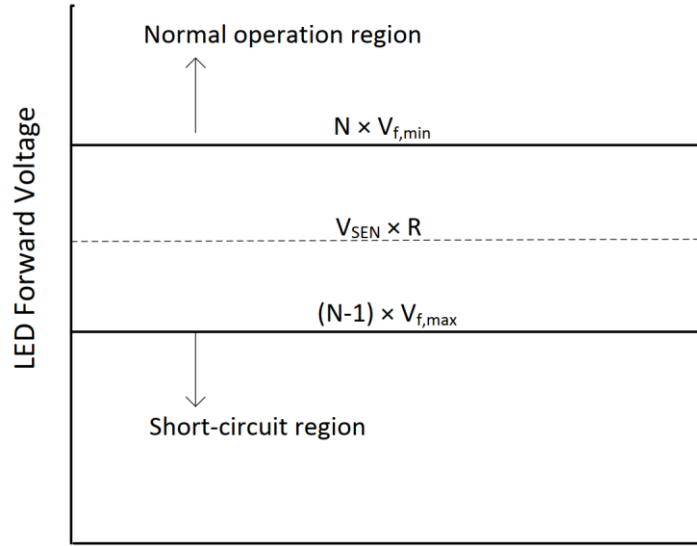

Figure 8 Single-LED Short-Trigger Calculation

Table 1. Fault Table.

FAILURE MODE	JUDGMENT CONDITION			Diagnostic Output Pins	Action	FAULT_A and FAULT_S	Device Reaction	Failure Removed	Self-clearing
	VIN Voltage	Channel Status	DETECTION MECHANISM						
Short circuit: 1 or several LED strings	$V(VIN) > 5V$	ON	$V(IOUTx) < 0.89V$	FAULT_A	Pulled low	Externally pulled high	Failing strings turned OFF, other channels ON	Toggle EN, power cycle	No
						Floating	All strings turned OFF		
Single-LED short circuit: 1 or several LED strings	$V(VIN) > 9V$	ON	$V(VSNSx) < 1.218V$	FAULT_S	Pulled low	Externally pulled high	All strings stay ON	Toggle EN, power cycle	No
						Floating	All strings stay ON		
Open load: 1 or several LED strings	$V(VIN) > 5V$	ON	$V(VIN) - V(IOUTx) < 100mV$	FAULT_A	Pulled low	Externally pulled high	All strings stay ON	N/A	Yes
						Floating	Failing string stays ON, other channels turned OFF	N/A	
Short to battery: 1 or several LED strings	$V(VIN) > 5V$	ON or OFF	$V(VIN) - V(IOUTx) < 100mV$	FAULT_A	Pulled low	Externally pulled high	All strings stay ON	N/A	Yes
						Floating	Failing string stays ON, other channels turned OFF	N/A	
Reference resistor open or shorted	$V(VIN) > 5V$	ON or OFF	$R_{(IADJ)} > 57k\Omega$ or $R_{(IADJ)} < 350\Omega$	FAULT_A	None	N/A	All strings turned OFF	Toggle EN, power cycle	No
Thermal shutdown	$V(VIN) > 5V$	ON or OFF	Temperature $> 170^\circ C$	FAULT_A	Pulled low	Externally pulled high	All strings turned OFF	Temperature $< 155^\circ C$	Yes
						Leave open			
Thermal foldback	$V(VIN) > 5V$	ON or OFF	Temperature $> 110^\circ C$	N/A	None	N/A	All strings with reduced current	Temperature $< 100^\circ C$	Yes

- (1) With diagnostic pins FAULT_A and FAULT_S tied high externally, pullup must be strong enough to override internal pulldown.
- (2) To achieve single-LED short circuit to turn off all strings, FAULT_A and FAULT_S pins must be connected together.
- (3) Pulling FAULT_A and FAULT_S high externally changes the behavior of the device reaction. If not externally forced high, the device pulls the pins low based on the failure mode.

5.8 OPERATION WITH $5\text{ V} < V(\text{VIN}) < 9\text{ V}$

The devices operate with input voltages above 5 V. When the input voltage is lower than normal automotive 9 V, the devices shield single-LED-short fault status. With fault status shielded, if a single-LED-short fault occurs the devices do not report the fault with the FAULT_S pin.

5.9 THERMAL INFORMATION

This device operates a thermal shutdown (TSD) circuit as a protection from overheating. For continuous normal operation, the junction temperature should not exceed the thermal-shutdown trip point. If the junction temperature exceeds the thermal-shutdown trip point, the output turns off. When the junction temperature falls below the thermal-shutdown trip point, the output turns on again.

Calculate the power dissipated by the device according to the following formula:

$$P_T = V_{VIN} \times I_{VIN} - n_1 \times V_{LED1} \times I_{LED1} - n_2 \times V_{LED2} \times I_{LED2} - n_3 \times V_{LED3} \times I_{LED3} - \frac{V_{IADJ}^2}{R_{IADJ}} \quad 4$$

P_T = Total power dissipation of the device

n_x = Number of LEDs for channel x

$V_{(LEDx)}$ = Voltage drop across one LED for channel x

$I_{(LEDx)}$ = Average LED current for channel x

V_{IADJ} = Reference voltage, typically 1.198 V

After determining the power dissipated by the device, calculate the junction temperature from the ambient temperature and the device thermal impedance.

$$T_J = T_A + R_{\theta JA} \times P_T \quad 5$$

6 ABSOLUTE MAXIMUM RATINGS

	Value	UNIT
VIN, IOUTx	-0.3 to 42	V
PWMx, EN, VSENx	-0.3 to 50	V
FAULT_A, FAULT_S	-0.3 to 30	V
TEMP, IADJ	-0.3 to 9	V

(1) Stresses beyond those listed under Absolute Maximum Ratings may cause permanent damage to the device. These are stress ratings only, and functional operation of the device at these or any other conditions beyond those indicated under Recommended Operating Conditions is not implied. Exposure to absolute-maximum-rated conditions for extended periods may affect device reliability.

(2) All voltage values are with respect to GND.

7 ATTRIBUTES

ESD Capability	
Human Body Model (HBM)	± 4000V
Charge Device Mode (CDM)	± 1000 V
Operating ambient temperature, T _A	
	-40 to 125°C
Junction Temperature, T _J	
	-40 to 150°C
Storage Temperature, T _{STG}	
	-65 to 150°C
Moisture Sensitivity	
	MSL 3

8 RECOMMENDED OPERATING CONDITIONS

	MIN	MAX	UNIT
VIN	5	40	V
IOUTx, PWMx, EN, VSENx	0	40	V
FAULT_A, FAULT_S	0	20	V
TEMP, IADJ	0	5	V

9 THERMAL INFORMATION

		UNIT
R _{θJA}	Junction-to-ambient thermal resistance	41.6 °C/W
R _{θJC(top)}	Junction-to-case (top) thermal resistance	26.8 °C/W
R _{θJB}	Junction-to-board thermal resistance	23.4 °C/W
R _{θJC(bot)}	Junction-to-case (bottom) thermal resistance	3.6 °C/W



10 ELECTRICAL CHARACTERISTICS

($V_{(VIN)} = 14\text{ V}$, $T_J = -40^\circ\text{C}$ to 140°C)

PARAMETER		TEST CONDITIONS	MIN	TYP	MAX	UNIT
Supply Voltage and Current (VIN)						
V_I	Input Voltage		5		40	V
$I_{(quiescent)}$	Quiescent current	All PWMx = high, $I_{(IOUTx)} = 100\text{ mA}$, Not including I_{IADJ}	0.55	0.7	1	mA
$I_{O(sd)}$	Shutdown current	$V_{(EN)} = 0\text{ V}$	40	50	150	μA
$I_{(fault)}$	Shutdown current in fault mode (device to GND)	PWM = EN = high, FAULT_A = low, $V_{(VIN)} = 5\text{-}40\text{ V}$, $I = 100\text{ mA}$	0.7	0.8	1.2	mA
	Shutdown current in fault mode (from $V_{(VIN)}$)	PWM = EN = high, FAULT_A = low, $V_{(VIN)} = 5\text{-}40\text{ V}$, $I = 100\text{ mA}$	1.5	1.8	2.2	
PWMx and EN						
$V_{IL(EN)}$	Logic input, low level	IOUTx disabled	0		0.7	V
$V_{IH(EN)}$	Logic input, high level	IOUTx enabled	2.0			V
$I_{(EN-pd)}$	EN internal pulldown	$V_{(EN)} = 0\text{ V}$ to 40 V	2.0	4.5	6	μA
$V_{IL(PWMx)}$	Logic input, low level	IOUTx disabled	1.13	1.182	1.26	V
$V_{IH(PWMx)}$	Logic input, high level	IOUTx enabled	1.16	1.218	1.29	V
$V_{hys(PWM)}$	Hysteresis		20	40	60	mV
$I_{(PWM-pd)}$	PWMx internal pulldown current	$V_{(PWMx)} = 40\text{ V}$	100	160	250	nA
IOUT (Output Current)						
$I_{(IOUTx)}$	Regulated output current range	Each channel	10		150	mA
		Three channels in parallel mode	30		450	
$\Delta I_{O(channel)}$	Channel accuracy	$30\text{mA} \leq I_{(IOUTx)} < 150\text{mA}$, $V_{(VIN)} = 5\text{-}40\text{V}$ Channel accuracy = $\frac{I_{IOUTx} - I_{AVG}}{I_{AVG}}$	-2%		2%	
$\Delta I_{O(device)}$	Device accuracy	$30\text{mA} < I_{(IOUTx)} < 150\text{mA}$, $V_{(VIN)} = 5\text{-}20\text{V}$ Device accuracy = $\frac{I_{IOUTx} - I_{SET}}{I_{SET}}$	-3%		3%	
V_{IADJ}	Reference voltage		1.195	1.198	1.235	V
$K_{(I)}$	Ratio of $I_{(IOUTx)}$ to reference current		98	100	102	
$V_{(DROP)}$	Channel dropout voltage	At 150 mA load per channel	0.7	0.8	1.2	V
		At 60 mA load per channel	0.2	0.3	0.6	
SR	Current rise and fall slew rate	Current rising from 10% to 90% or falling from 90% to 10% at $I_{(IOUTx)} = 60\text{ mA}$.	10	17	40	mA/ μs
		Current rising from 10% to 90% or falling from 90% to 10% at $I_{(IOUTx)} = 150\text{ mA}$.	15	21	40	mA/ μs

* $I_{(AVG)} = [I_{(IOUT1)} + I_{(IOUT2)} + I_{(IOUT3)}] / 3$

* $I_{(SET)}$ is the target current set by R_{ref}



PARAMETER		TEST CONDITIONS	MIN	TYP	MAX	UNIT
FAULT_A and FAULT_S						
V_{IL}	Logic input low threshold				0.7	V
V_{IH}	Logic input high threshold		2.0			V
V_{OL}	Logic output low level		0	0.35	0.7	V
V_{OH}	Logic output high level		2	3.5	5	V
$I_{(pulldown)}$	Strong pulldown current		550	790	1000	μ A
$I_{(pullup)}$	Weak pullup current		3	7	16	μ A
COMPARATOR (VSENx)						
$V_{(VSENx)}$	Internal comparator reference		1.195	1.218	1.235	V
I_{kg}	Leakage current	$V_{(VSENx)} = 3\text{ V}$	0	100	500	nA
$V_{(th)}$	Voltage at which the chip enables the single-short alarm function		8.0	8.5	9.0	V
	$V_{(th)}$ hysteresis			150		mV
PROTECTION						
$V_{(OLV)}$	Open-load detection voltage	$V_{(OLV)} = V_{(VIN)} - V_{(IOUTx)}$	60	100	150	mV
$V_{(OL-hys)}$	Open-load detection hysteresis		200	300	400	mV
$V_{(SV)}$	Short-detection voltage		0.84	0.87	0.93	V
	Short-detection hysteresis		320	340	360	mV
	Short-detection deglitch		1	2	3	ms
		During PWM, count the number of continuous cycles when $V_{(VSNSx)} < 1.24\text{ V}$	7		8	Cycles
	Single-short detection deglitch		1	2	3	ms
		During PWM, count the number of continuous cycles when $V_{(VSENx)} < 1.24\text{ V}$	7		8	Cycles
	Open-load detection deglitch		1	2	3	ms
		During PWM, count the number of continuous cycles when $V_{(VIN)} - V_{(IOUTx)} < V_{(OLV)}$	7		8	Cycles
$R_{(IADJ_open)}$	IADJ pin resistor open detection		40	54	65	k Ω
$R_{(IADJ_short)}$	IADJ pin resistor short detection		350	500	800	Ω
THERMAL PROTECTION						
$T_{(shutdown)}$	Thermal shutdown		155	170	175	$^{\circ}$ C
$T_{(hys)}$	Thermal shutdown hysteresis			15		$^{\circ}$ C
$T_{(th)}$	Thermal foldback activation temperature	90% of I_{OUTx} normal (TEMP pin floating)	105	120	135	$^{\circ}$ C
$I_{(TFCmin)}$	Minimum foldback current		40%	50%	60%	
$V_{(T-disable)}$	Thermal foldback function disable voltage			0	0.2	V
TIMING REQUIREMENTS						
$t_{(startup)}$	Start-up time	$V_{(VIN)} > 5\text{ V}$, $I_{(IOUTx)} = 50\%$, $I_{(set)} = 60\text{ mA}$	50	100	150	μ s
$t_{d(on)}$	Delay time between PWM rising edge to 10% of $I_{(IOUTx)}$		3	4.5	6	μ s
$t_{d(off)}$	Delay time between PWM falling edge to 90% of $I_{(IOUTx)}$		5	6.5	8	μ s

11 TYPICAL CHARACTERISTICS

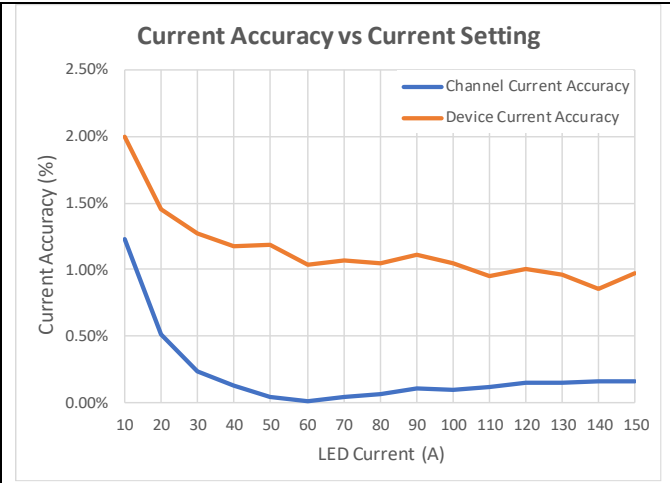

Figure 1. Current Accuracy vs Current Setting
 $V_{(VIN)} = 14\text{ V}$, 3 LEDs

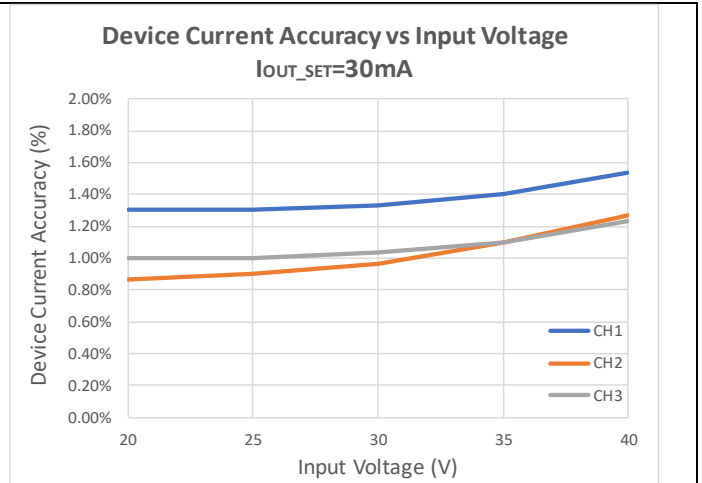

Figure 2. Device Current Accuracy vs Input Voltage
 $I_{OUT_SET}=30\text{mA}$

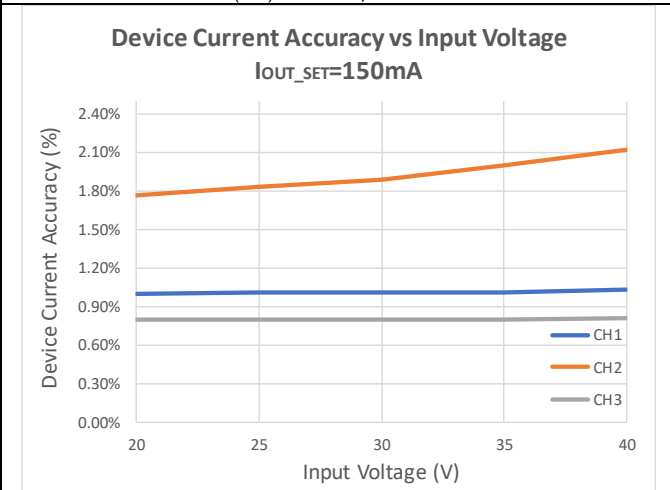

Figure 3. Device Current Accuracy vs Input Voltage
 $I_{OUT_SET}=150\text{mA}$

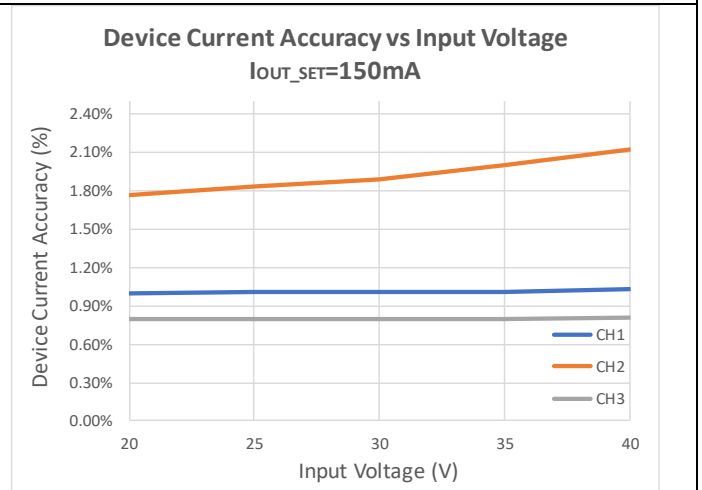

Figure 4. Output Current vs External Resistance
 $I_{OUT_SET}=150\text{mA}$

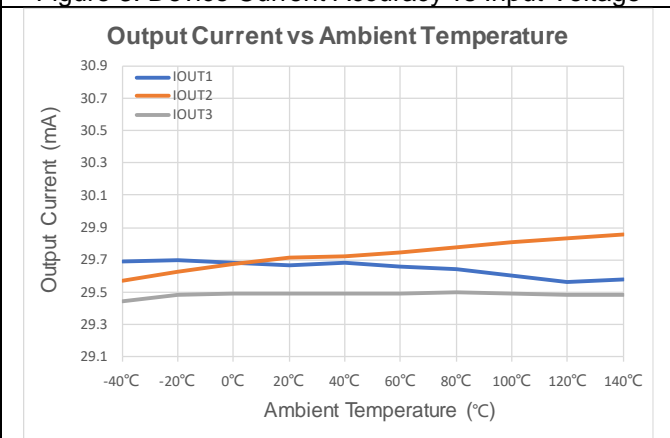

Figure 5. Output Current vs Ambient Temperature
 $V_{(VIN)} = 14\text{ V}$, 3 LEDs

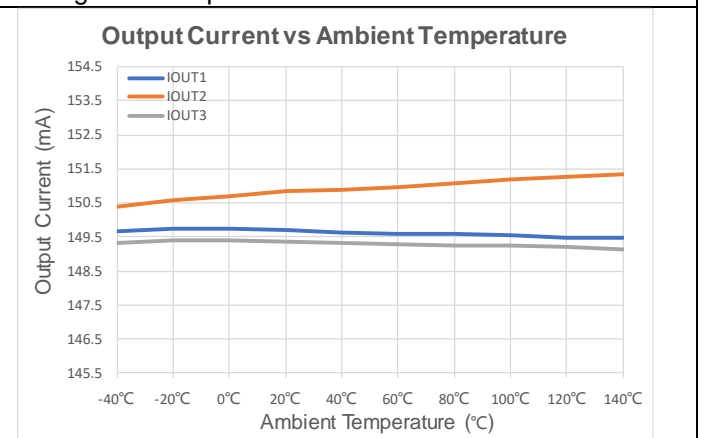

Figure 6. Output Current vs Ambient Temperature
 $V_{(VIN)} = 14\text{ V}$, 3 LEDs

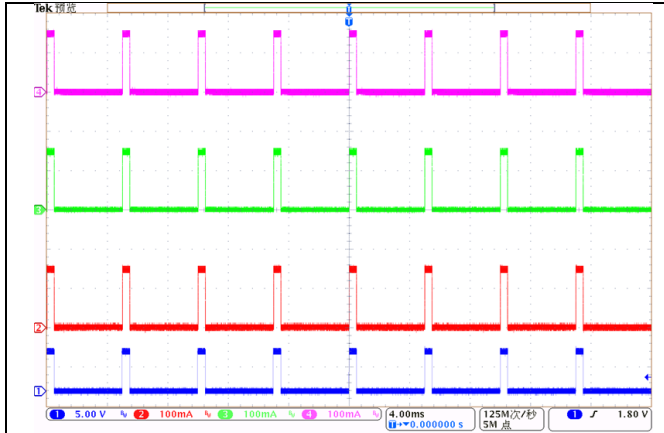

Figure 7. PWM Dimming $f_{(PWM)} = 200$ Hz, $D = 10\%$
CH1=PWM,CH2=IOUT1,CH3=IOUT2,CH4=IOUT3

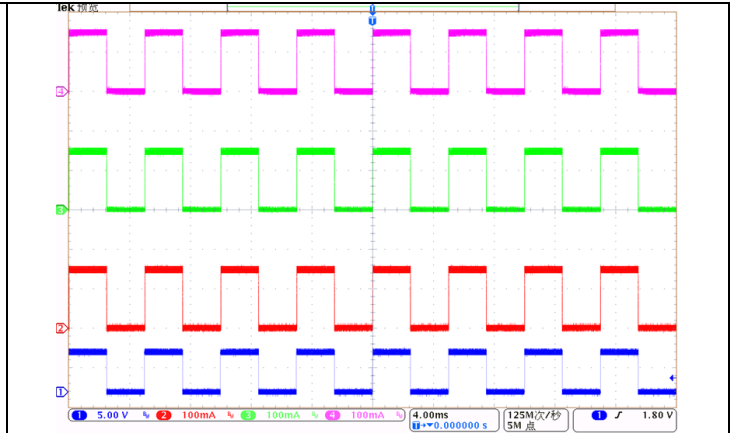

Figure 8. PWM Dimming $f_{(PWM)} = 200$ Hz, $D = 50\%$
CH1=PWM,CH2=IOUT1,CH3=IOUT2,CH4=IOUT3

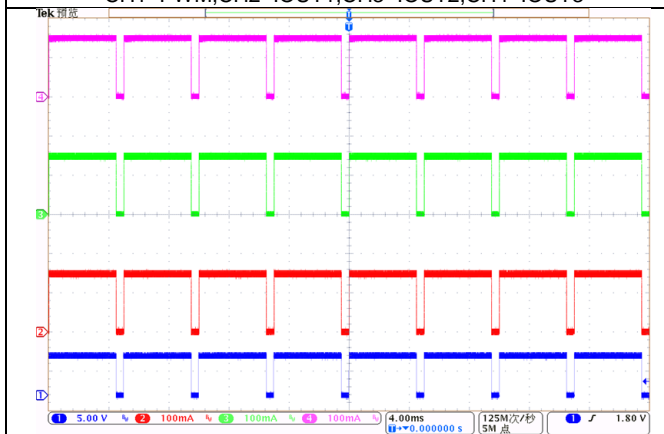

Figure 9. PWM Dimming $f_{(PWM)} = 200$ Hz, $D = 90\%$
CH1=PWM,CH2=IOUT1,CH3=IOUT2,CH4=IOUT3

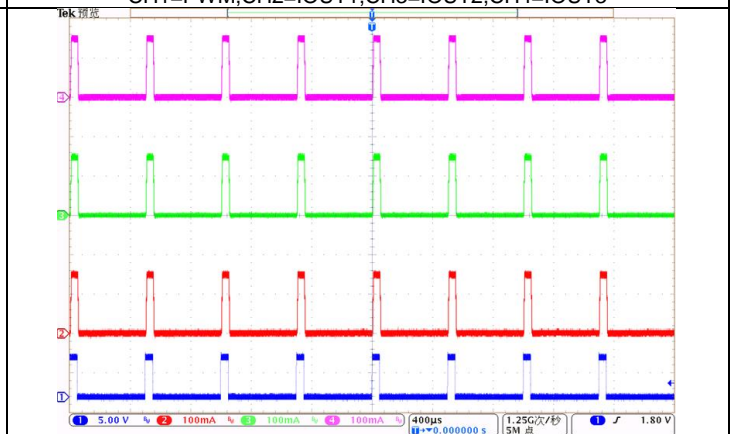

Figure 10. PWM Dimming $f_{(PWM)} = 2000$ Hz, $D = 10\%$
CH1=PWM,CH2=IOUT1,CH3=IOUT2,CH4=IOUT3

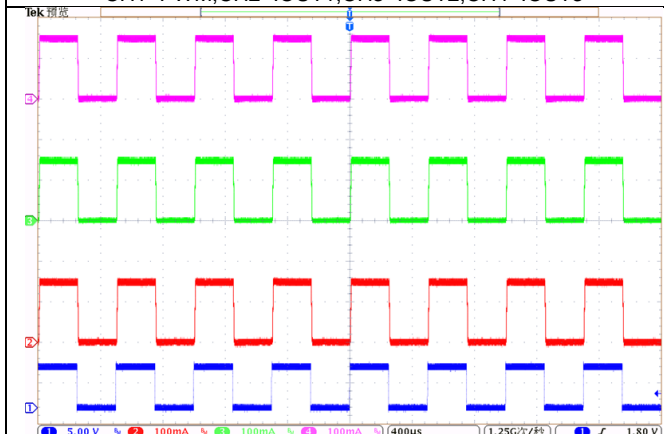

Figure 11. PWM Dimming $f_{(PWM)} = 2000$ Hz, $D = 50\%$
CH1=PWM,CH2=IOUT1,CH3=IOUT2,CH4=IOUT3

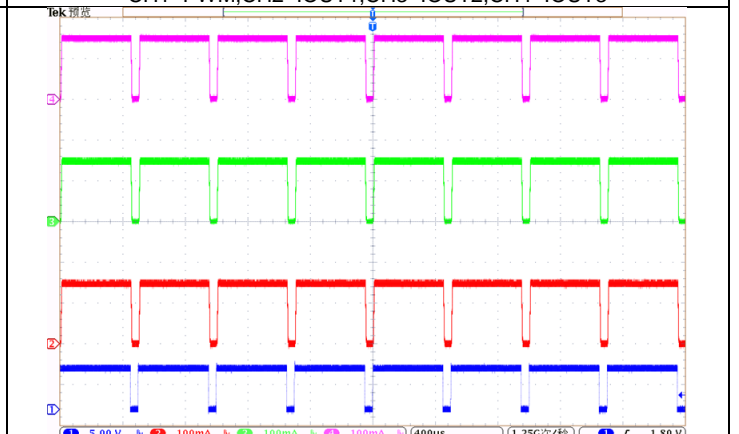
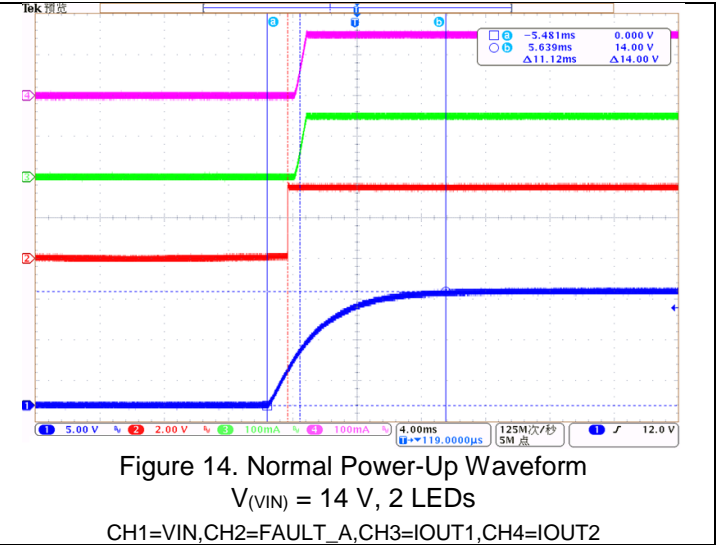
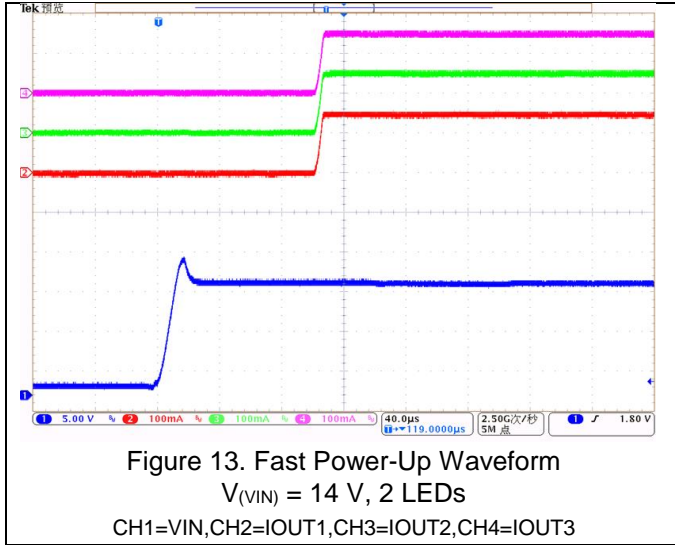

Figure 12. PWM Dimming $f_{(PWM)} = 2000$ Hz, $D = 90\%$
CH1=PWM,CH2=IOUT1,CH3=IOUT2,CH4=IOUT3



12 DESIGN GUIDE

12.1 STOPLIGHT AND TAILLIGHT APPLICATION

For many automobiles, the same set of LEDs illuminates both taillights and stop lights. Thus, the LEDs must operate at two different brightness levels. Figure 9 shows two-level brightness adjustment using the PT16977 device with minimum external components. Set the dimming level with a parallel resistor in IADJ through an external MOS.

It recommends to add capacitors at VIN and IOUTx. An input capacitor of at least 1 μF close to the VIN pin, and output capacitors of 10 nF close to the IOUTx pins. Larger capacitors are helpful for EMC and ESD; however, it takes a longer time to charge up the capacitor and could affect PWM dimming performance.

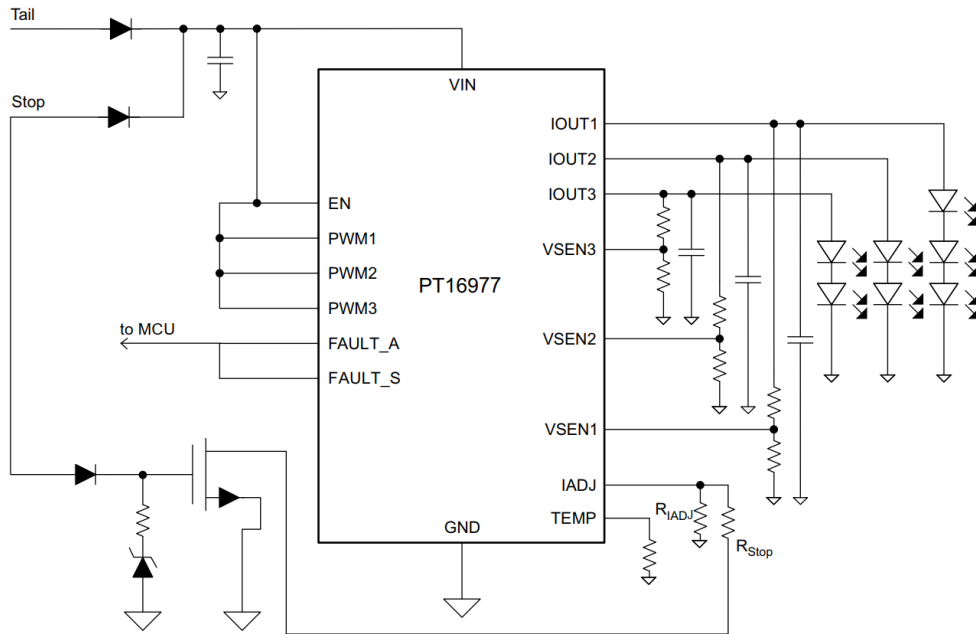

Figure 9. Two-Level Brightness Adjustment Application

LED current can be calculated as follows:

$$I_{STOP} = \frac{V_{IADJ} \times K_I}{(R_{IADJ} \times R_{STOP}) / (R_{IADJ} + R_{STOP})}$$

$$I_{TAIL} = \frac{V_{IADJ} \times K_I}{R_{IADJ}} \quad 7$$

$$R_{STOP} = \frac{V_{IADJ} \times K_I}{I_{STOP} - I_{TAIL}} \quad 8$$

V_{IADJ} = Reference Voltage: 1.198 V (typ)
 K_I = Ratio of $I_{(IOUTx)}$ to reference current: 100(typ)

12.2 PARALLEL CONNECTION

This device can drive up to three strings with one to three LEDs in each string, at a total current up to 150 mA per channel. Outputs can be paralleled to provide higher current drive up to 450 mA. For example, if the load current is up to 2 times the device rating, connect the outputs of two devices in parallel as shown in Figure 10.

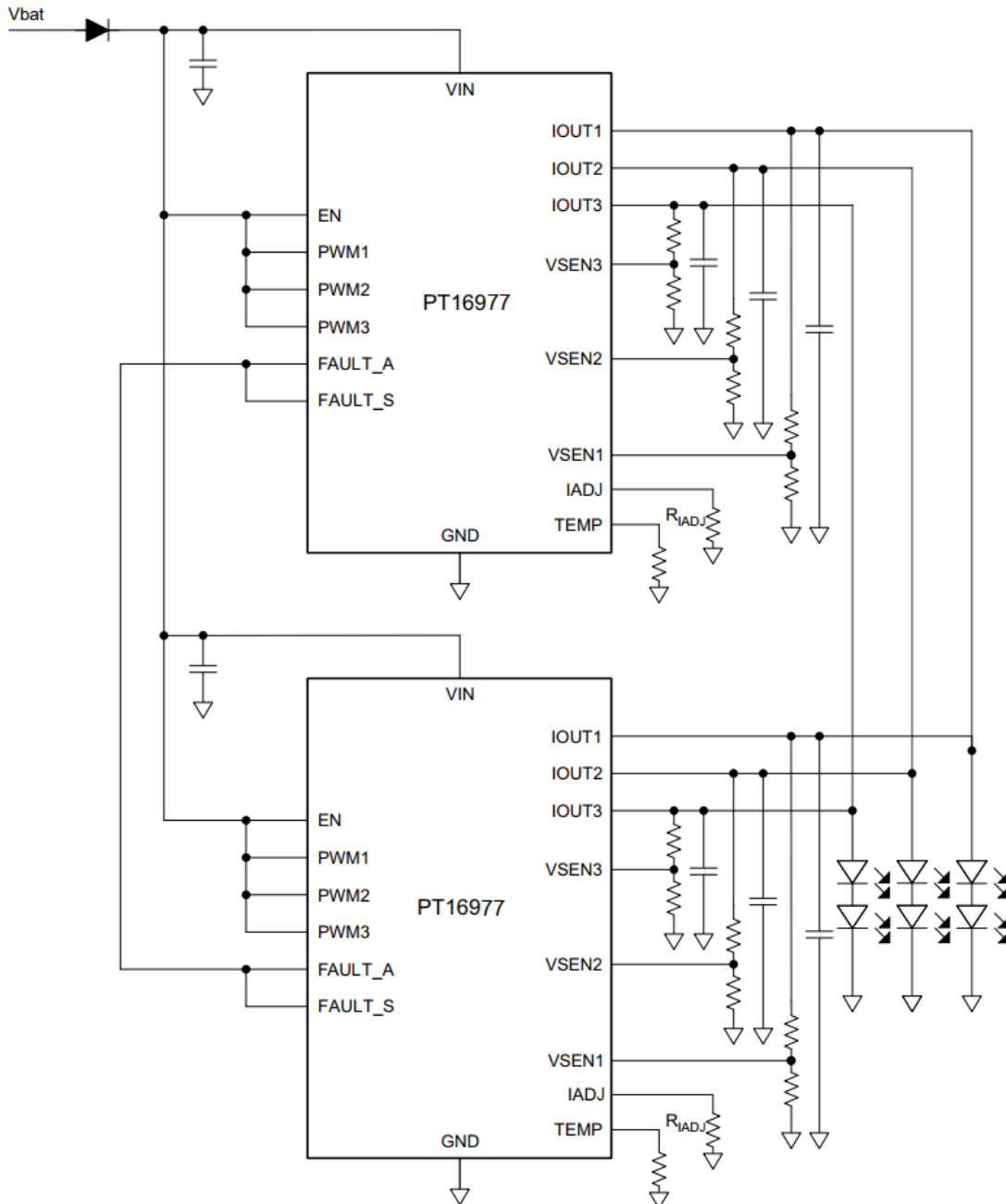

Figure 10. Devices in Parallel Application

12.3 HIGH-SIDE PWM DIMMING

If the system has no MCU or PWM, one can use the high-side driver to do the dimming directly. When using the high-side driver to do PWM dimming, a resistor divider must be put in the PWM pin in case of current overshoot on the PWM rising edge. The resistor divider is needed to turn off the channel before the next PWM rising edge. Figure 11 shows the details.

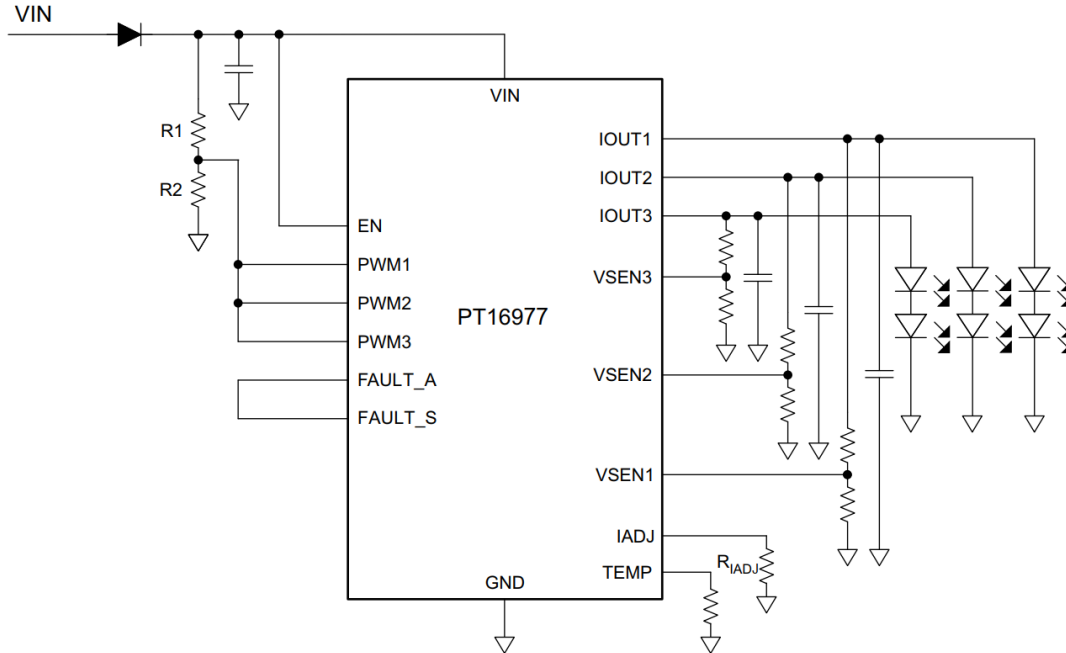

Figure 11. High-Side PWM Dimming

Measure the voltage on the VIN pin when the high-side dimming voltage is at a low level. Then calculate the ratio of R1 / R2 using the formula of Equation 9.

$$\frac{R1}{R2} = \frac{VIN_{LOW} + 0.1}{1.178 \times 0.95}$$

9

12.4 LAYOUT GUIDELINES

In order to prevent thermal shutdown, T_J must be less than 150°C. If the input voltage is very high, the power dissipation might be large. The PCB layout is also very important. Good PCB design can optimize heat transfer, which is absolutely essential for the long-term reliability of the device.

- Maximize the copper coverage on the PCB to increase the thermal conductivity of the board, because the major heat-flow path from the package to the ambient is through the copper on the PCB. Maximum copper is extremely important when the design does not include heat sinks attached to the PCB on the other side of the package.
- Add as many thermal vias as possible directly under the package ground pad to optimize the thermal conductivity of the board.
- All thermal vias should be either plated shut or plugged and capped on both sides of the board to prevent solder voids. To ensure reliability and performance, the solder coverage should be at least 85%.

PACKAGE INFORMATION

HTSSOP16

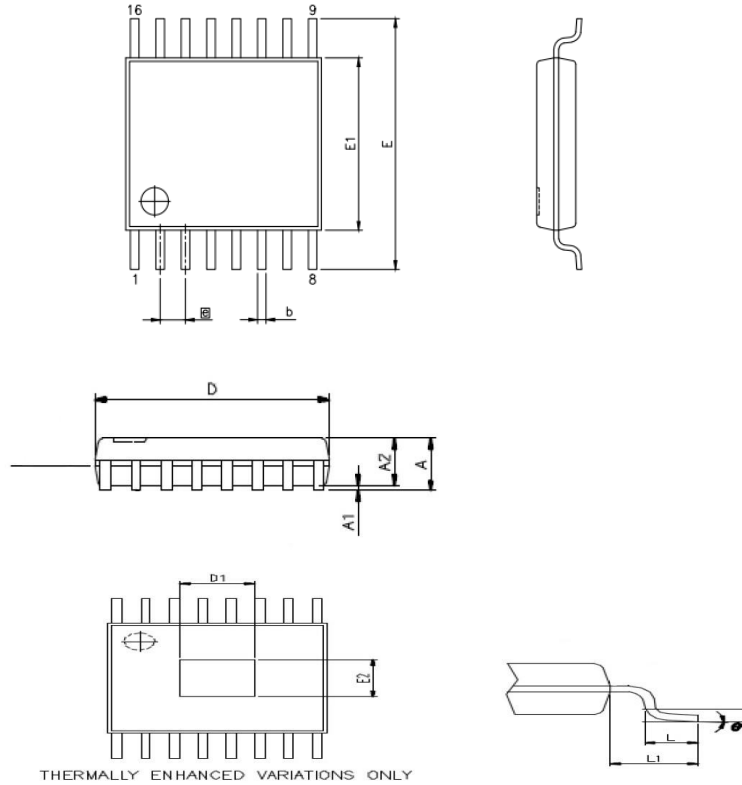

SYMBOL	MILLIMETER		
	MIN	NOM	MAX
A	-	-	1.2
A1	0.05	-	0.15
A2	0.8	1	1.05
b	0.19	-	0.30
D	4.90	5.00	5.10
E1	4.30	4.40	4.50
E	6.40 BSC		
e	0.65 BSC		
L1	1.00 REF		
L	0.45	0.60	0.75
S	0.20	-	-
θ	0°	-	8°

Thermally Enhanced Dimensions (mm)

Pad Size	E2		D1	
	MIN	MAX	MIN	MAX
118 X 11	2.40	3.00	2.40	3.00

Note: 1. Refer JEDEC MO-153 AB
 2. Unit: millimeter

IMPORTANT NOTICE

Princeton Technology Corporation (PTC) reserves the right to make corrections, modifications, enhancements, improvements, and other changes to its products and to discontinue any product without notice at any time.

PTC cannot assume responsibility for use of any circuitry other than circuitry entirely embodied in a PTC product. No circuit patent licenses are implied.

Princeton Technology Corp.
2F, 233-1, Baociao Road,
Sindian Dist., New Taipei City 23145, Taiwan
Tel: 886-2-66296288
Fax: 886-2-29174598
<http://www.princeton.com.tw>