

DESCRIPTION

The PT2464 provides 2 channel Full-On H-Bridge drivers. The output driver features wide operating range from 2.0V and low power consumption. It also provides fast switching speed in a compact surface mount package.

APPLICATION

- Single-lens reflex camera system
- Mobile system
- Home appliance
- Amusement system

FEATURES

- Range of motor power supply voltage:
 - Control (VCC) : 2.5V to 5.5V
 - Motor (VM) : 2.0V to 16V
- Low current consumption when power-down: <math><1\mu\text{A}</math>@25°C
- Ultra low RDS(ON)(TOP+BOT): 0.4Ω(TYP)@25°C
- Charge pump-less, P-channel DMOS as upper side switches
- H-bridge output current (DC):
 - For SOP and WCSP package: ±1.8A(Max.)
 - For QFN package: ±2.8A(Max.)
- High-speed switching:
 - Turn On Time: 200ns, Turn Off Time: 80ns (Typ.)
- Operating temperature range: -30°C to +85°C
- Built-in protection circuits
 - Under Voltage Lock Out (UVLO)
 - Thermal Shut Down (TSD)

BLOCK DIAGRAM

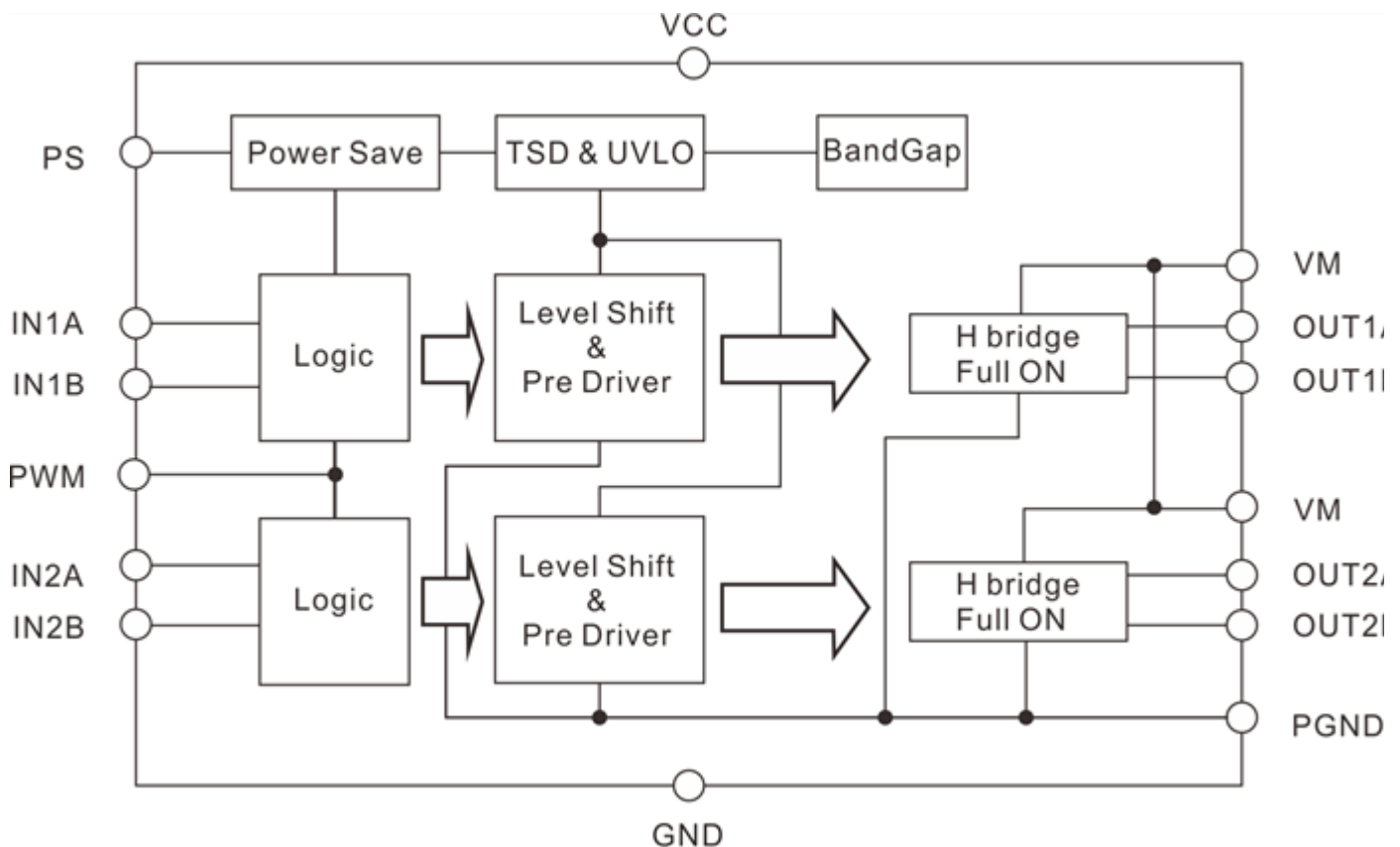

APPLICATION CIRCUIT

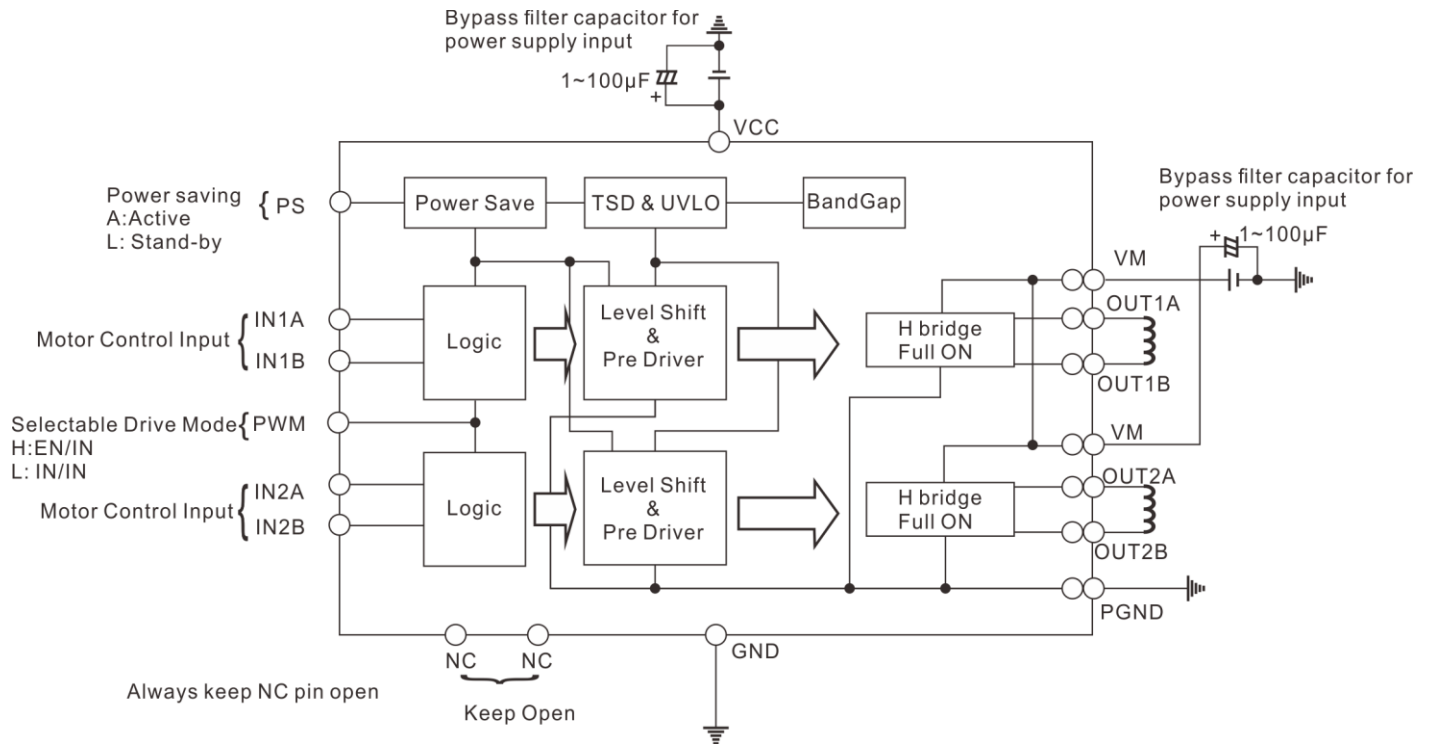

Note: The VM pin group includes pin 9, 10 and pin 21, 22 should be short-circuit connection by PCB track or pattern. If cannot, check into transitional characteristics of total application circuit including two motors. Through low impedance materials, the possibility of causing some unexpected malfunctions is incontrovertible.

ORDER INFORMATION

Part Number	Package Type	Top Code
PT2464	24 Pins, QFN, 4*4mm	PT2464
PT2464-S	16 Pins, SOP	PT2464-S
PT2464	15 Balls, WCSP	2464

PIN CONFIGURATION

QFN24 (TOP VIEW)

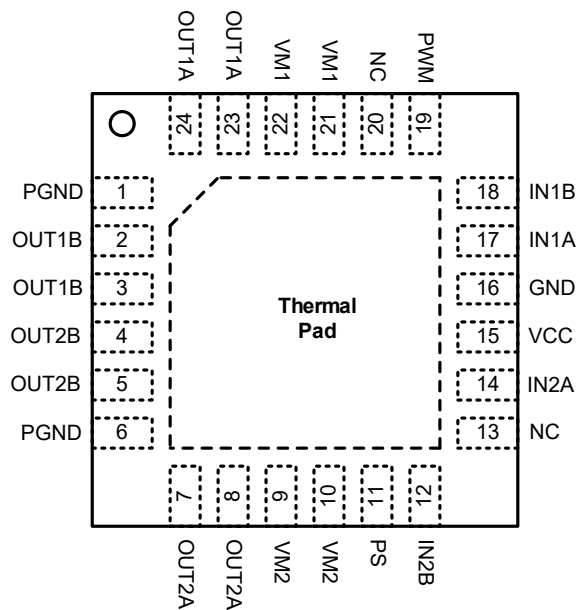

WCSP (TOP VIEW)

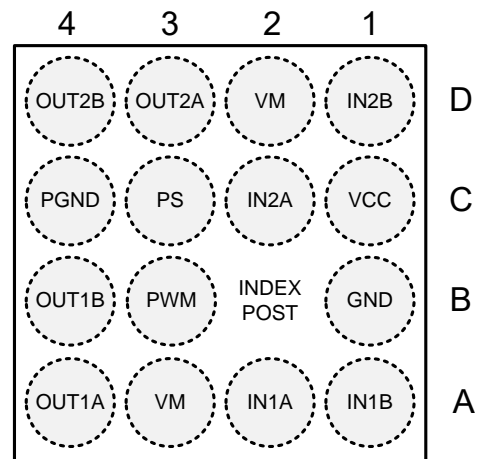

SOP16 (TOP VIEW)

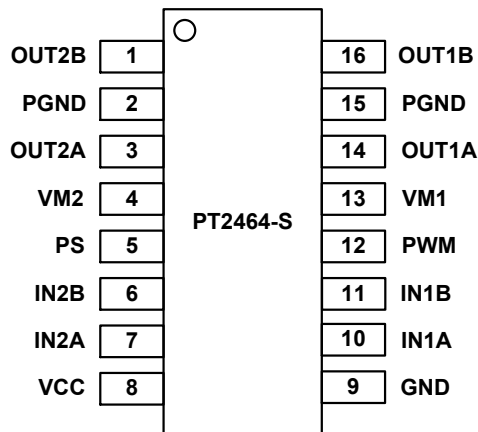

PIN DESCRIPTION

QFN, 24 PINS

Pin Name	I/O	Description	Pin No.
PGND	GND	Motor ground terminal	1
OUT1B	O	H-bridge output terminal ch.1B	2
OUT1B	O	H-bridge output terminal ch.1B	3
OUT2B	O	H-bridge output terminal ch.2B	4
OUT2B	O	H-bridge output terminal ch.2B	5
PGND	GND	Motor ground terminal	6
OUT2A	O	H-bridge output terminal ch.2A	7
OUT2A	O	H-bridge output terminal ch.2A	8
VM2	Power	Motor power supply terminal	9
VM2	Power	Motor power supply terminal	10
PS	I	Power-saving terminal	11
IN2B	I	Control input terminal ch.2B	12
N.C.	-	No connect.	13
IN2A	I	Control input terminal ch.2A	14
VCC	Power	Power supply terminal	15
GND	GND	Ground terminal	16
IN1A	I	Control input terminal ch.1A	17
IN1B	I	Control input terminal ch.1B	18
PWM	I	Drive mode selection pin	19
N.C.	-	No connect.	20
VM1	Power	Motor power supply terminal	21
VM1	Power	Motor power supply terminal	22
OUT1A	O	H-bridge output terminal ch.1A	23
OUT1A	O	H-bridge output terminal ch.1A	24

Note: Each of the same named terminals (VM1, VM2, PGND, OUT1A, OUT1B, OUT2A, OUT2B) must be connected together on the PCB (Printed Circuit Board).

SOP, 16 PINS

Pin Name	I/O	Description	Pin No.
OUT2B	O	H-bridge output terminal ch.2B	1
PGND	GND	Motor ground terminal	2
OUT2A	O	H-bridge output terminal ch.2A	3
VM2	Power	Motor power supply terminal	4
PS	I	Power-saving terminal	5
IN2B	I	Control input terminal ch.2B	6
IN2A	I	Control input terminal ch.2A	7
VCC	Power	Power supply terminal	8
GND	GND	Ground terminal	9
IN1A	I	Control input terminal ch.1A	10
IN1B	I	Control input terminal ch.1B	11
PWM	I	Drive mode selection pin	12
VM1	Power	Motor power supply terminal	13
OUT1A	O	H-bridge output terminal ch.1A	14
PGND	GND	Motor ground terminal	15
OUT1B	O	H-bridge output terminal ch.1B	16

Note: The same named terminals (VM1 & VM2, PGND) must be connected together on the PCB (Printed Circuit Board).

WCSP, 15 BALLS

Pin Name	I/O	Description	Pin No.
IN1B	I	Control input terminal ch.1B	A1
IN1A	I	Control input terminal ch.1A	A2
VM	Power	Motor power supply terminal	A3
OUT1A	O	H-bridge output terminal ch.1A	A4
GND	GND	Ground terminal	B1
INDEX POST	-	Empty space for alignment index.	B2
PWM	I	Drive mode selection pin	B3
OUT1B	O	H-bridge output terminal ch.1B	B4
VCC	Power	Power supply terminal	C1
IN2A	I	Control input terminal ch.2A	C2
PS	I	Power-saving terminal	C3
PGND	GND	Motor ground terminal	C4
IN2B	I	Control input terminal ch.2B	D1
VM	Power	Motor power supply terminal	D2
OUT2A	O	H-bridge output terminal ch.2A	D3
OUT2B	O	H-bridge output terminal ch.2B	D4

Note: The same named terminals (VM) must be connected together on the PCB (Printed Circuit Board).

INPUT/OUTPUT CONFIGURATION

IN1A, IN1B, IN2A, IN2B, PWM

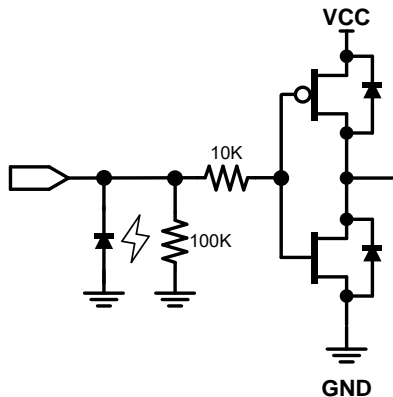

VM, PGND, OUTxA, OUTxB

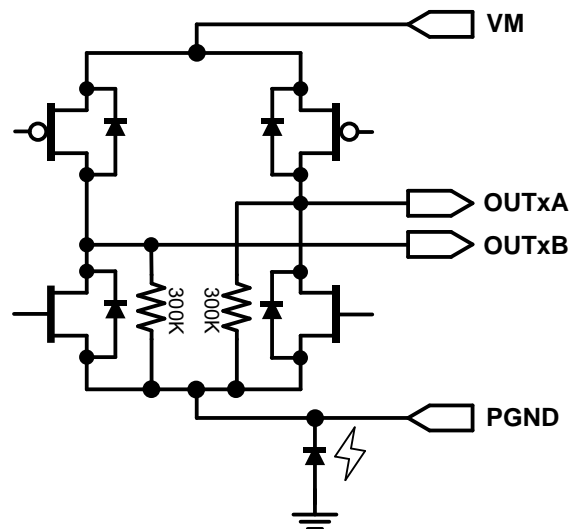

PS

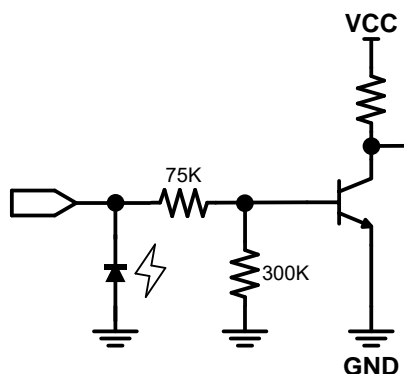

FUNCTION DESCRIPTIONS

INPUT-OUTPUT LOGIC TABLE

Input Mode	INPUT				OUTPUT			
	PS	PWM	IN1A/IN2A	IN1B/IN2B	OUT1A/2A	OUT1B/2B	Output Mode	
EN/IN	H	H	L	X	L	L	Short Brake	
			H	L	H	L	CW	
			H	H	L	H	CCW	
IN/IN		L	L	L	L	Z	Z	Open
				H	L	H	L	CW
				L	H	L	H	CCW
				H	H	L	L	Short Brake
-	L	X	X	X	Z	Z	Open	

Note: L: Low, H: High, X: Don't care, Z: Hi impedance PS=High, Operation Mode; PS=Low, Stand-by Mode
CW: current flows from OUTA to OUTB, CCW: current flows from OUTB to OUTA.

INPUT-OUTPUT AC DEFINITION

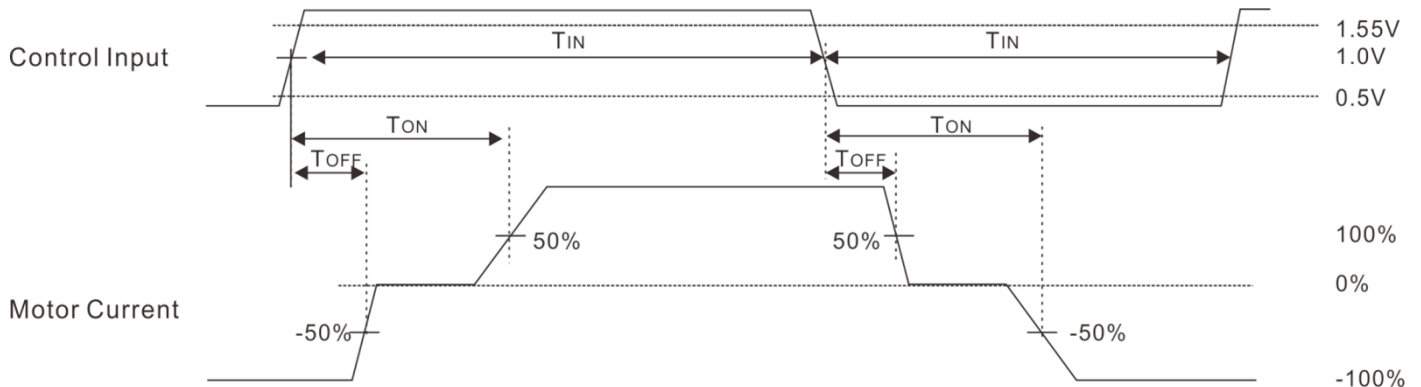

APPLICATION NOTES

1) ABSOLUTE MAXIMUM RATINGS

Use of the IC in excess of absolute maximum ratings such as the applied voltage or operating temperature range (T_{opr}) may result in IC damage. Assumptions should not be made regarding the state of the IC (short mode or open mode) when such damage is suffered. The implementation of a physical safety measure such as a fuse should be considered when use of the IC in a special mode where the absolute maximum ratings may be exceeded is anticipated.

2) POWER SUPPLY PINS AND LINES

None of the VM line for the H-bridge is internally connected to the VCC power supply line, which is only for the control logic or analog circuit. Therefore, the VM and VCC lines can be driven at different voltages. Although these lines can be connected to a common power supply, do not open the power supply pin but connect it to the power supply externally. Regenerated current may flow as a result of the motor's back electromotive force. Insert capacitors between the power supply and ground pins to serve as a route for regenerated current. Determine the capacitance in full consideration of all the characteristics of the electrolytic capacitor, because the electrolytic capacitor may lose some capacitance at low temperatures. If the connected power supply does not have sufficient current absorption capacity, regenerative current will cause the voltage on the power supply line to rise, which combined with the product and its peripheral circuitry may exceed the absolute maximum ratings. It is recommended to implement a physical safety measure such as the insertion of a voltage clamp diode between the power supply and ground pins.

For this IC with 2 power supplies and a part consists of the CMOS block, it is possible that rush current may flow instantaneously due to the internal powering sequence and delays, and to the unstable internal logic, respectively. Therefore, give special consideration to power coupling capacitance, width of power and ground wirings, and routing of wiring.

3) GROUND PINS AND LINES

Ensure a minimum GND pin potential in all operating conditions. Make sure that no pins are at a voltage below the GND at any time, regardless of whether it is a transient signal or not.

When using both small signal GND and large current PGND patterns, it is recommended to isolate the two ground patterns, placing a single ground point at the application's reference point so that the pattern wiring resistance and voltage variations caused by large currents do not cause variations in the small signal ground voltage. Be careful not to change the GND wiring pattern of any external components, either.

The power supply and ground lines must be as short and thick as possible to reduce line impedance.

4) THERMAL DESIGN

Use a thermal design that allows for a sufficient margin in light of the power dissipation (P_d) in actual operating conditions.

5) ACTIONS IN STRONG MAGNETIC FIELD

Use caution when using the IC in the presence of a strong magnetic field as doing so may cause the IC to malfunction.

6) ASO

When using the IC, set the output transistor for the motor so that it does not exceed absolute maximum ratings or ASO.

7) THERMAL SHUTDOWN CIRCUIT

This IC incorporates a TSD (thermal shutdown) circuit. If the temperature of the chip reaches the following temperature, the motor coil output will be opened. The TSD circuit is designed only to shut the IC off to prevent runaway thermal operation. It is not designed to protect the IC or guarantee its operation. Do not continue to use the IC after operating this circuit or use the IC in an environment where the operation of this circuit is assumed.

TSD ON temperature [°C] (Typ.)	Hysteresis temperature [°C] (Typ.)
175	20

8) N.C. PIN

Always keep N.C. pins open.

9) THERMAL PAD

Connect the Thermal PAD with a small signal GND terminal.

10) APPLICATION EXAMPLE

The application circuit is recommended for use. Make sure to confirm the adequacy of the characteristics. When using the circuit with changes to the external circuit constants, make sure to leave an adequate margin for external components including static and transitional characteristics as well as dispersion of the IC.

ABSOLUTE MAXIMUM RATINGS

Parameter	Symbol	Limit	Unit	Note	
Power supply voltage	VCC	-0.3 to +5.5	V		
Motor power supply voltage	VM	-0.3 to +16.0	V		
Control input voltage	VIN	-0.3 to VCC+0.3	V		
Power dissipation	Pd	QFN	730	mW	Note 1
		SOP	870		
		WCSP	1450		Note 2
H-bridge output current (DC)	IOUT	QFN	±2.8	A	Note 3
		SOP	±1.8		
		WCSP	±1.8		
H-bridge output current (AC)	IOUT1	±3.2		Note 4	
	IOUT2	±4.0		Note 5	
Storage temperature range	Tstg	-40 to +150	°C		
Junction temperature	Tjmax	+150	°C		

Note 1 : Reduced by 5.84mW/°C over 25°C, when mounted on a glass epoxy 1-layer board (74.2mm x 74.2mm x 1.6mm) in surface layer copper foil area: 10.29mm².

Note 2 : Reduced by 11.6mW/°C over 25°C, when mounted on a glass epoxy 2-layer board (74.2mm x 74.2mm x 1.6mm) in surface layer copper foil area: 10.29mm².

Note 3 : Must not exceed Pd, ASO, or Tjmax of 150°C.

Note 4 : Terminal OUTA,OUTB pulse width =100ms, pulse length = 500ms (Duty cycle ≦ 20%)

Note 5 : Terminal OUTA,OUTB pulse width =10ms, pulse length = 200ms (Duty cycle ≦ 5%)

Operation outside the Absolute Maximum Ratings may cause permanent device damage. These ratings are stress limits only, and functional operation of the device at these or any other conditions beyond those specified under Recommended Operating Conditions is not guaranteed. Operating outside the Recommended Operating Conditions but within the Absolute Maximum Ratings may impair device functionality, reliability, or longevity.

PACKAGE THERMAL DERATINGS

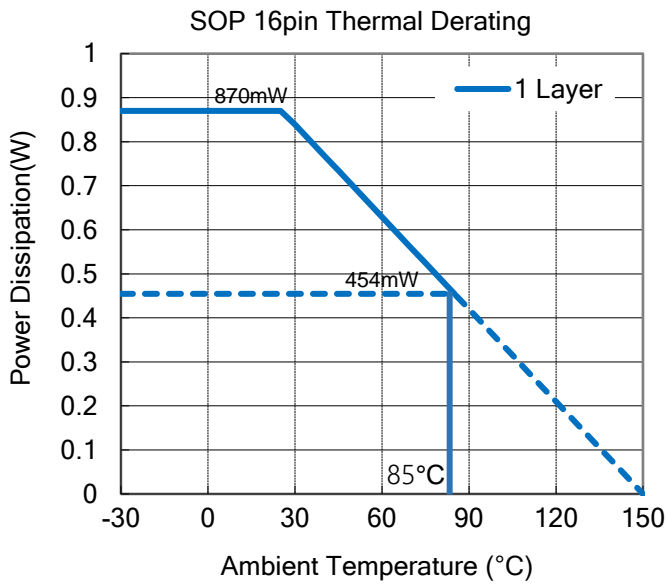
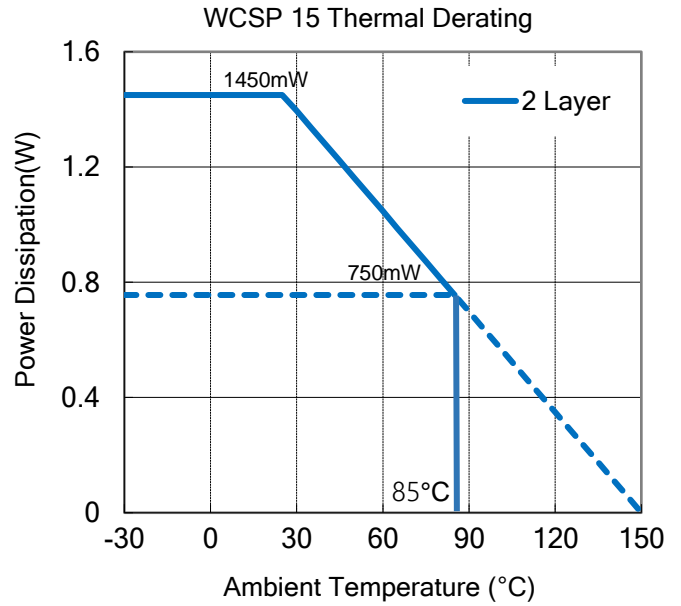
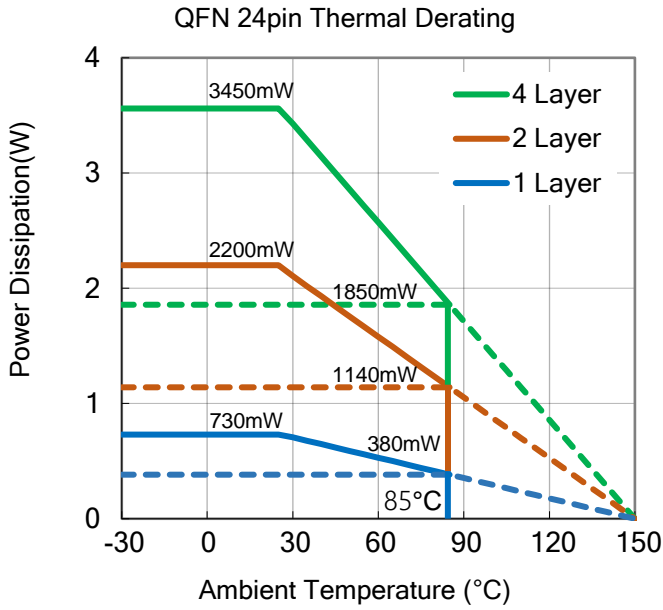

RECOMMENDED OPERATION CONDITIONS

Parameter	Symbol	Min.	Typ.	Max.	Unit
Power Supply Voltage	VCC	2.5	-	5.5	V
Motor Power Supply Voltage	VM	2.0	-	16	V
Control Input Voltage	VIN	0	-	VCC	V
Logic Input Frequency	FIN	0	-	500	KHz
Min. Logic Input Pulse Width (note)	TIN	0.5	-	-	μs
Operating Temperature Range	Topr	-30	+25	+85	°C

Note: there is no shoot through current when the logic input pulse width is equal or smaller than 0.5μs.

Functional operation is guaranteed only within the Recommended Operating Conditions. Operation outside this range may result in degraded performance, reduced reliability, or shortened lifetime of the device.

ELECTRICAL CHARACTERISTICS

 (Unless otherwise specified, $T_a=25^{\circ}\text{C}$, $V_{CC}=3.0\text{V}$, $V_M=7.4\text{V}$)

Parameter	Symbol	Test Condition	Min.	Typ.	Max.	Unit
All Circuits Current						
Stand-by Current	I_{CCST}	$V_{PS}=0\text{V}$	-	0	1	μA
Circuit Current 1	I_{CC1}	$V_{PS}=3\text{V}$, Open Mode	-	0.35	0.55	mA
Circuit Current 2	I_{CC2}	$V_{PS}=3\text{V}$, CW & CCW Mode	-	0.55	0.75	mA
Circuit Current 3	I_{CC3}	$V_{PS}=3\text{V}$, Short Brake Mode	-	0.55	0.75	mA
Vcc Current						
Circuit Current 1	I_{VCC1}	$V_{PS}=3\text{V}$, Open Mode	-	0.25	0.35	mA
Circuit Current 2	I_{VCC2}	$V_{PS}=3\text{V}$, CW & CCW Mode	-	0.25	0.35	mA
Circuit Current 3	I_{VCC3}	$V_{PS}=3\text{V}$, Short Brake Mode	-	0.25	0.35	mA
VM Current						
Circuit Current 1	I_{VM1}	$V_{PS}=3\text{V}$, Open Mode	-	0.1	0.2	mA
Circuit Current 2	I_{VM2}	$V_{PS}=3\text{V}$, CW & CCW Mode	-	0.3	0.4	mA
Circuit Current 3	I_{VM3}	$V_{PS}=3\text{V}$, Short Brake Mode	-	0.3	0.4	mA
PS Input (PS)						
High-Level Input Voltage	VPSH		1.45	-	V_{CC}	V
Low-Level Input Voltage	VPSL		0	-	0.5	V
High-Level Input Current	IPSH	$V_{PS}=3\text{V}$	15	30	60	μA
Low-Level Input Current	IPSL	$V_{PS}=0\text{V}$	-1	0	1	μA
Control Input (IN=IN1A, IN1B, IN2A, IN2B, PWM)						
High-Level Input Voltage	VINH		1.55	-	V_{CC}	V
Low-Level Input Voltage	VINL		0	-	0.5	V
High-Level Input Current	IINH	$V_{IN}=3\text{V}$	15	30	60	μA
Low-Level Input Current	IINL	$V_{IN}=0\text{V}$	-1	0	1	μA
Under Voltage Locked Out (UVLO)						
UVLO Voltage	UV1	VCC pin, all outputs off	2.0	-	-	V
	UV2	VCC pin, all outputs on	-	-	2.4	V
Full ON Type H-Bridge Driver						
Output ON-Resistance	R_{ON}	$I_{OUT}=\pm 500\text{mA}$, Upper & Lower Total	-	0.4	0.6	Ω
Pull Down Resistance	R_{PD}	Open Mode	240	300	360	$\text{K}\Omega$
Turn On Time	T_{ON}	20 Ω Loaded	140	200	300	ns
Turn Off Time	T_{OFF}	20 Ω Loaded	55	80	100	ns
Thermal Shut Down						
TSD ON Temperature	T_{SD}	All outputs off	155	175	-	$^{\circ}\text{C}$
Hysteresis Temperature	T_{HY}		-	20	-	$^{\circ}\text{C}$

PACKAGE INFORMATION

QFN, 24 PINS

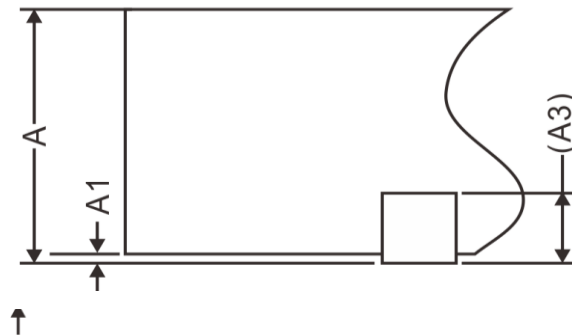
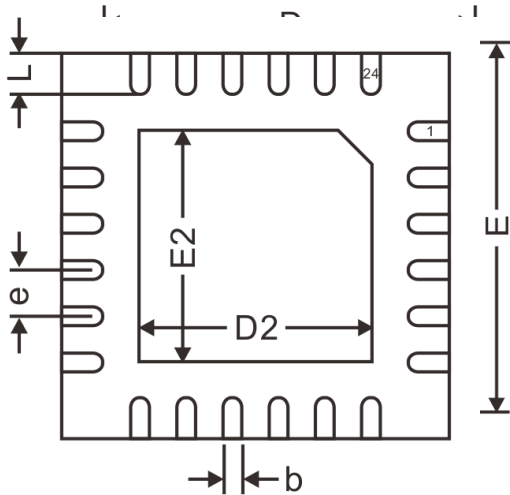

Symbol	Dimensions		
	Min.	Nom.	Max.
A	0.70	0.75	0.80
A1	0.00	0.02	0.05
A3		0.20 REF.	
b	0.18	0.25	0.30
D		4.00BSC	
E		4.00BSC	
D2	2.50	2.65	2.80
E2	2.50	2.65	2.80
e		0.50 BSC	
L	0.35	0.40	0.45

Notes:

1. All dimensions refer to JEDEC MO-220 VGGD-6
2. All dimensions are in millimeter.

WCSP, 15 BALLS

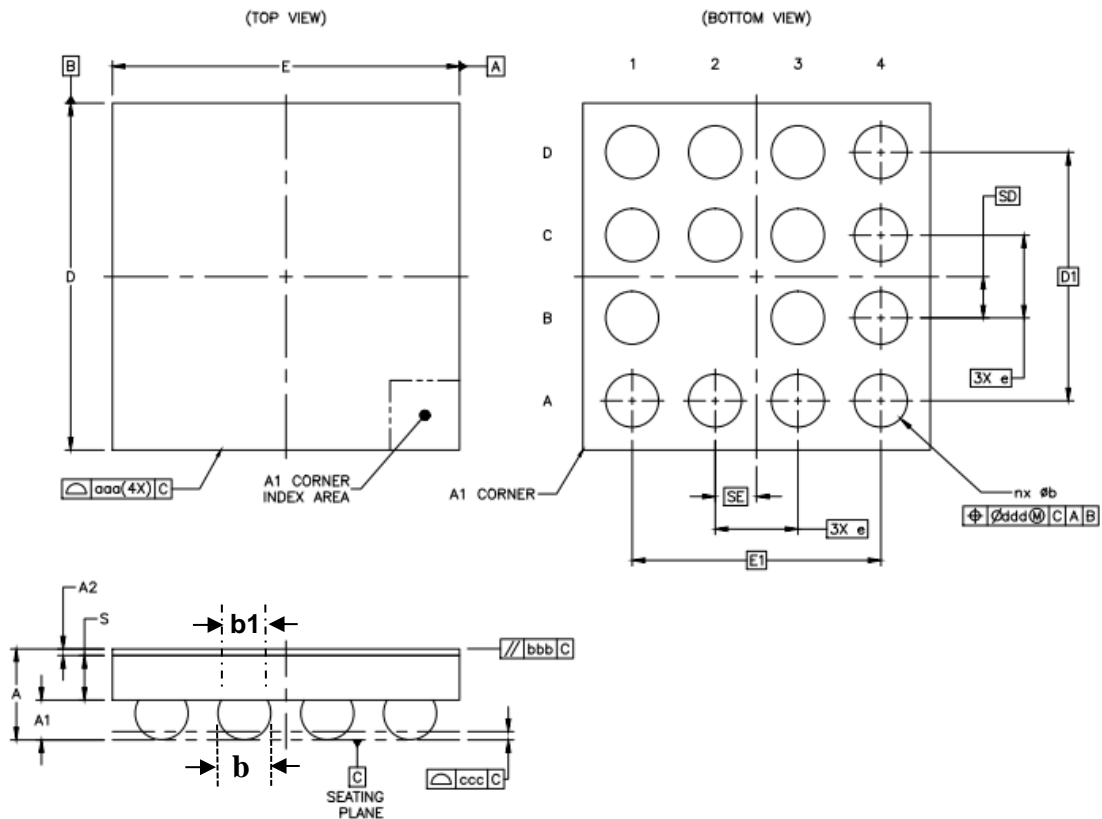

		Symbol	Common Dimensions
TOTAL THICKNESS		A	0.55 ± 0.059
WAFER THICKNESS		S	0.27 ± 0.025
STAND OFF		A1	0.21 ~ 0.27
FILM THICKNESS		A2	0.04 ± 0.004
BODY SIZE	X	E	2.095
	Y	D	2.095
BALL/BUMP PITCH	X	SE	0.25 BSC
	Y	SD	0.25 BSC
EDGE BALL CENTER TO CENTER	X	E1	1.5 BSC
	Y	D1	1.5 BSC
PITCH		e	0.5 BSC
UBM PAD DIAMETER (UBMに搭載前の半田ボール径)		b1	0.3 ± 0.004
BALL/BUMP WIDTH		b	0.29 ~ 0.35
BALL/BUMP COUNT		n	15
PACK EDGE TOLERANCE		aaa	0.03
WAFER FLATNESS		bbb	0.06
COPLANARITY		ccc	0.05
BALL/BUMP OFFSET (PACKAGE)		ddd	0.015

Notes:

- All dimensions are in millimeter.

SOP, 16PINS

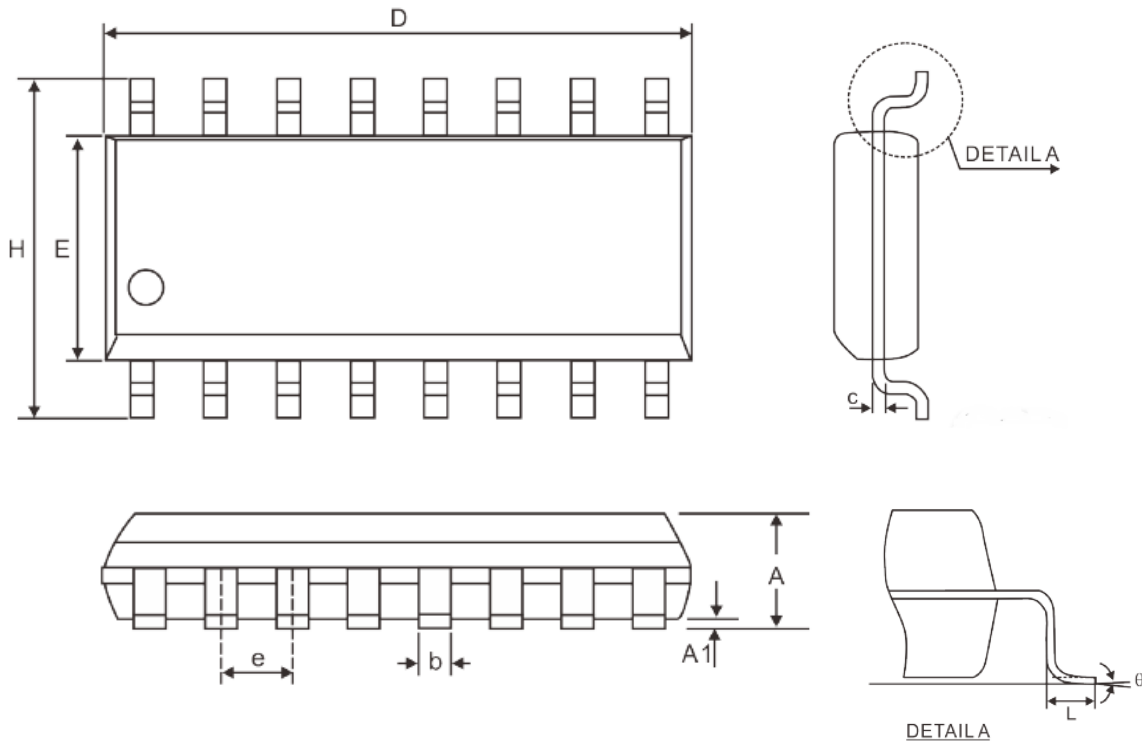

Symbol	Dimensions		
	Min.	Nom.	Max.
A	1.35	-	1.75
A1	0.1	-	0.25
b	0.31	-	0.51
c	0.10	-	0.25
e	1.27 BSC		
D	9.90 BSC		
H	6.00 BSC		
E	3.90 BSC		
L	0.4	-	1.27
θ	0°	-	8°

Notes:

1. All dimensions refer to JEDEC MS-012 AC
2. All dimensions are in millimeter.

IMPORTANT NOTICE

Princeton Technology Corporation (PTC) reserves the right to make corrections, modifications, enhancements, improvements, and other changes to its products and to discontinue any product without notice at any time.

PTC cannot assume responsibility for use of any circuitry other than circuitry entirely embodied in a PTC product. No circuit patent licenses are implied.

Princeton Technology Corp.
2F, 233-1, Baociao Road,
Sindian, Taipei 23145, Taiwan
Tel: 886-2-66296288
Fax: 886-2-29174598
<http://www.princeton.com.tw>