

DESCRIPTION

The PT2474 is a dual channel H-bridge motor driver that operates on wide supply voltage range from 4V to 16V. The control logic pins have built-in phase generator function; it could drive a four-wire bipolar stepping motor with only 2 input pins. The input waveform is generated by the external MCU and phase relation between two input pins is a standard full-step excitation.

APPLICATIONS

- Airflow flap control for refrigerators.
- Air Conditioner venting control
- Home appliance
- Office automation machines

FEATURES

- Wide Supply Voltage Range: 4V to 16V
- Single voltage supply with built-in regulator; control logic supply is not necessary.
- Dual H-bridge Drivers for a bipolar stepping motor
- MOSFET RDS(on) Resistance, HS + LS = 1.2Ω
- Maximum Output Current: 1.0 Amp (Peak), 700mA (RMS).
- Low Power Sleep mode
- Built-in Protection Circuits with Thermal Shutdown (TSD), Under Voltage Lock-Out (UVLO)
- Output current limiting (OCL) during output terminal shorted to GND.
- 10Pins Small Outline Package (SOP), Pitch=1.0mm.

BLOCK DIAGRAM

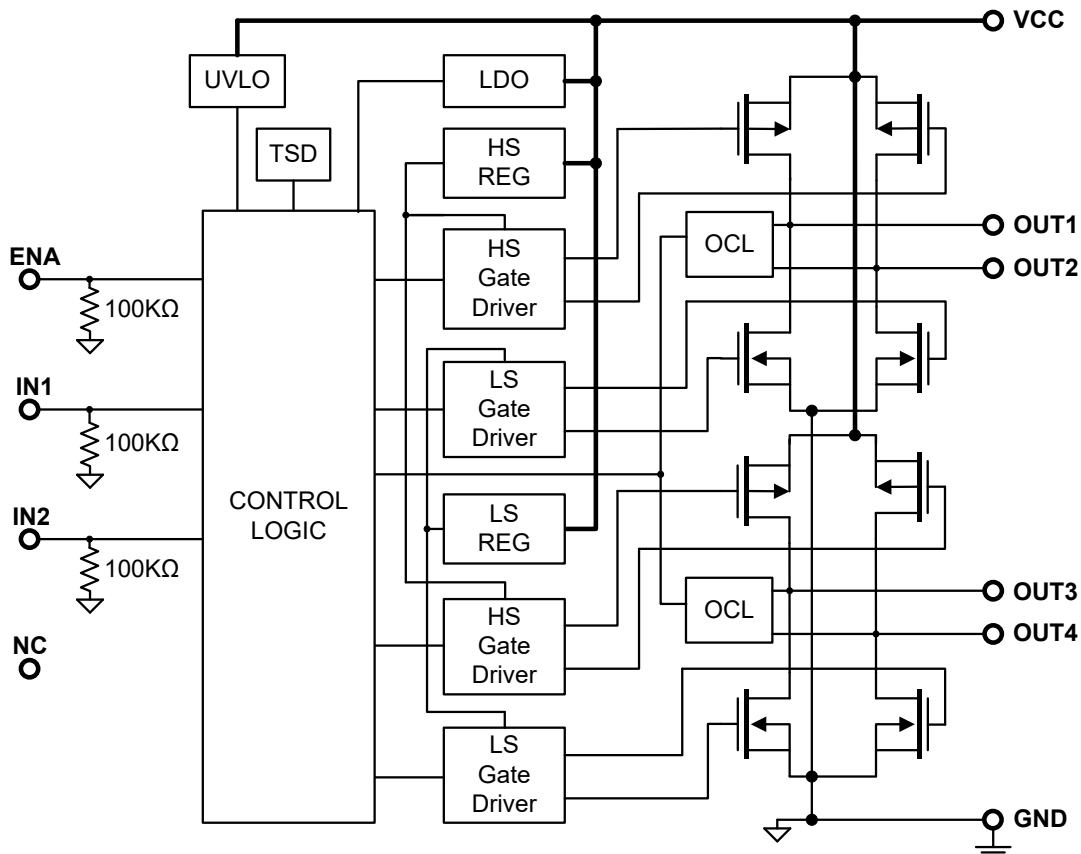

APPLICATION CIRCUIT

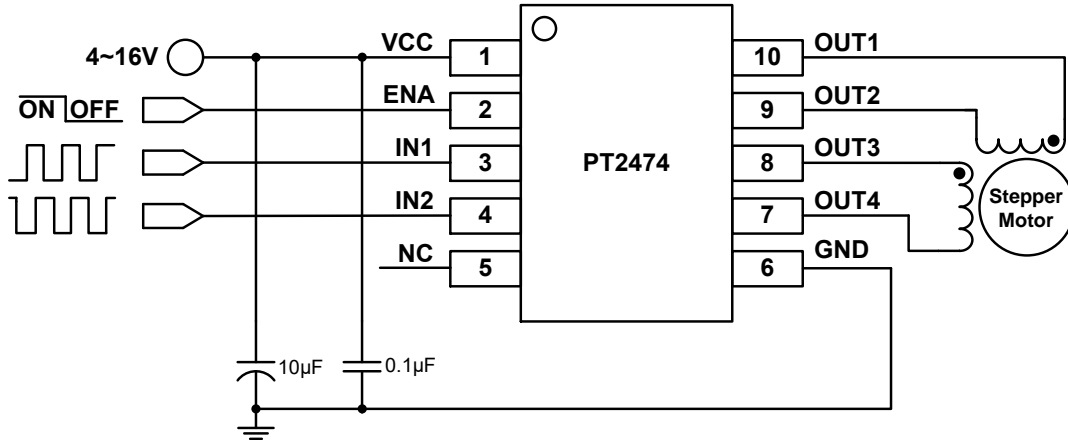

ORDER INFORMATION

Valid Part Number	Package Type	Top Code
PT2474-S	10Pins, SOP	PT2474-S

PIN CONFIGURATION

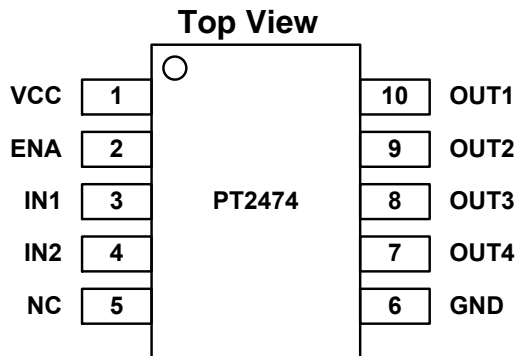

PIN DESCRIPTION

Pin Name	I/O	Description	Pin No.
VCC	Power	Power input pin, the operation voltage is from 4V to 16V. Connects a 0.1µF bypass capacitor between VCC and GND pin and add at least 10µF capacitor in the power line.	1
ENA	I	Chip Enable control input, Logic H=enable, logic L=stand-by.	2
IN1	I	Control input pin 1 for H-bridge driver 1, built-in a 100KΩ pull-down resistor.	3
IN2	I	Control input pin 2 for H-bridge driver 1, built-in a 100KΩ pull-down resistor.	4
NC	--	No connect. Do not connects this pin to any circuit.	5
GND	Power	Ground pin	6
OUT4	O	OUT4 of H-bridge driver 2	7
OUT3	O	OUT3 of H-bridge driver 2	8
OUT2	O	OUT2 of H-bridge driver 1	9
OUT1	O	OUT1 of H-bridge driver 1	10

FUNCTION DESCRIPTION

The PT2474 is a dual H-bridge motor driver integrates P-channel and N-channel MOSFET switches. The PT2474 powered from a single supply and range from 4V to 16V, and it could drives output current up to 1.0 Amp to the motor, the output current is determinate by motor winding resistance; winging inductance and back EMF and VCC supply voltage. The P2474 has low power sleep mode could reduce quiescent current down to less than 3μA to minimize system standby consumption.

H-BRIDGE OUTPUT CONFIGURATION

The motor winding current direction is determinate by input logic status, and output polarity between the OUT1 and OUT2 (or OUT3 and OUT4) is opposite phase. This logic configuration is specially design for a 4-wire bipolar stepping motor with full step excitation, because of the OUT1 and 2 (or OUT3 and 4) is always keeps in opposite phase polarity, therefore only two logic inputs (IN1, IN2) is needs for full step drives. Please refer to Table 1 for corresponds between input and output.

ENA	VCC	IN1	IN2	OUT1	OUT2	OUT3	OUT4	DESCRIPTION
L	X	x	x	Hi-Z	Hi-Z	Hi-Z	Hi-Z	Low power sleep mode.
H	<UVLO	x	x	Hi-Z	Hi-Z	Hi-Z	Hi-Z	All outputs in high impedance states,
H	>UVLO	L	L	H	L	H	L	Step 1
H		H	L	L	H	H	L	Step 2
H		H	H	L	H	L	H	Step 3
H		L	H	H	L	L	H	Step 4

Table 1. H-Bridge Output Operation

INPUT LOGIC FOR FULL-STEP EXCITATION

The full-step drives clock signals are applying to IN1 and IN2, both signal should be keeps on 50% duty cycle and with 90° phase shifted. The output current of H-bridge 1(OUT1-2) and H-bridge-2(OUT3-4) is a standard full-step excitation. During the ENA pulls to high, all of outputs need a reset time to wake-up internal circuit before fully operation.

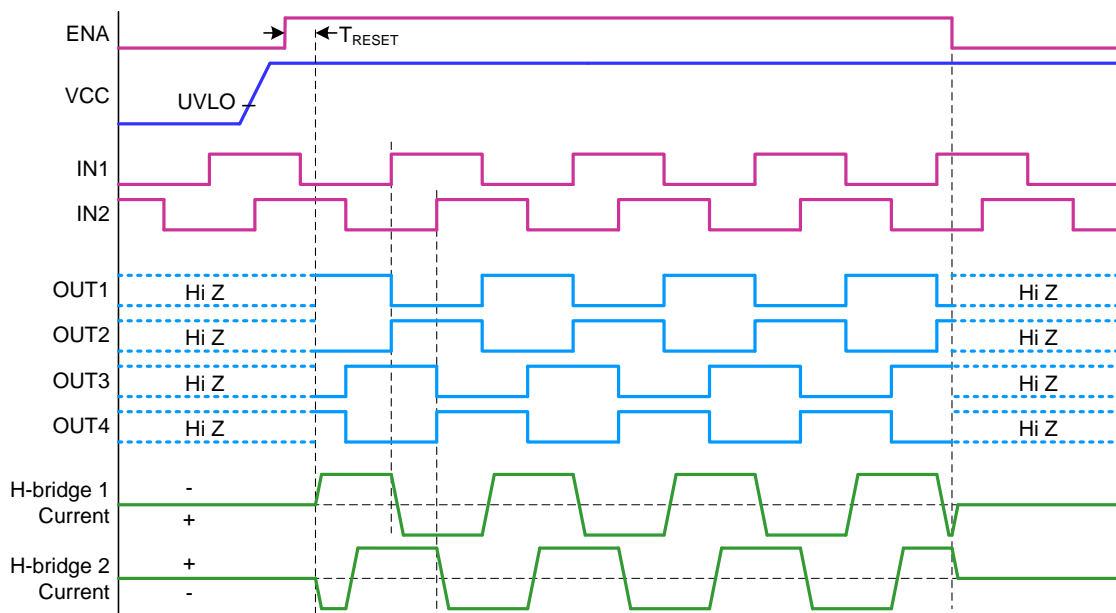

Figure 1. Full-Step Excitation Waveform for a Bipolar Step Stepping Motor

OUTPUT CURRENT LIMITING (OCL)

If any H-bridge output terminal is short circuits to GND unintentionally, or the motor winding is short internally, the Output Current Limiting (OCL) circuit will suppress the output current under 1.0 Amp; this function can help the driver staying on safe operation area and avoid over current stresses. If short circuit event is not removes, the chip junction temperature will rise and finally trigger the thermal shutdown (TSD) to turn off the output.

THERMAL SHUTDOWN (TSD)

If the chip junction temperature exceeds internal preset threshold 170°C, the H-bridge will be turn off. Once the chip temperature is under the hysteresis window, the H-bridge outputs will re-enable.

UNDERVOLTAGE LOCKOUT (UVLO)

If the VCC pin voltage drops below the under voltage lockout threshold (3.8V), the H-bridge outputs will be disabled and internal logic state will be reset. Operation will resume when VCC voltage rises above the UVLO threshold.

POWER SUPPLY BYPASS AND LAYOUT GUIDE

The parasitic inductance between the power supply and the motor driver will limits the current slew rate, and if local bounce absorb capacitance is not enough, the parasitic inductance/capacitance will easily goes oscillation and causes system unstable. Therefore, the VCC pin should be bypassing to GND with a 0.1μF low-ESR MLCC capacitor in minimum distance, and a 10μF bypass capacitor should be placed on the VCC power line track, the PCB track between the VCC pin and power input terminal (also the GND track) should be a thick trace or polygon connection.

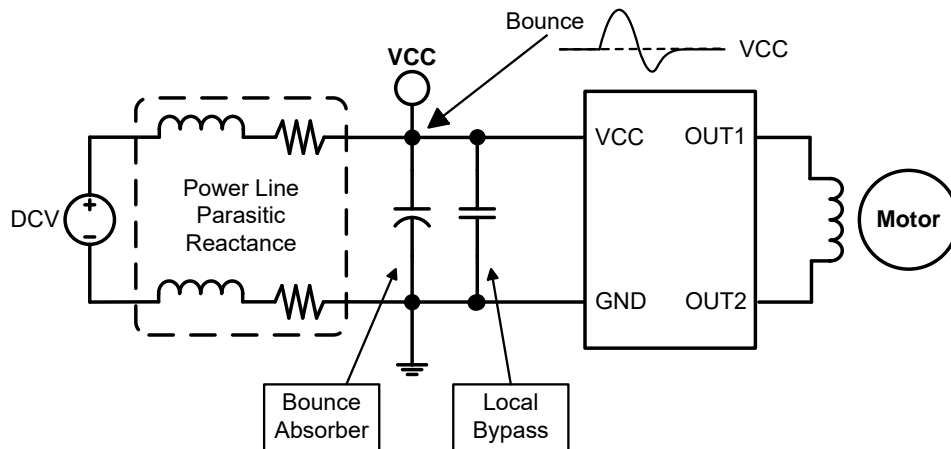

Figure 3 : Example Setup of Motor Drive System with External Power Supply

ABSOLUTE MAXIMUM RATINGS

Parameter	Symbol	Min.	Max.	Unit
Supply voltage	V_{CC}	-0.3	20	V
Digital pin voltage	V_{IN}	-0.3	7	V
Output current	I_{OUT}		1	A
Operating temperature	T_{opr}	-40	85	°C
Storage temperature	T_{stg}	-40	150	°C
ESD, Human body model	HBM	-4000	+4000	V
ESD, Machine model	MM	-400	+400	V

ELECTRICAL CHARACTERISTICS

$T_A=25^{\circ}\text{C}$, $V_{CC}=12\text{V}$, over recommended operating conditions unless otherwise noted

Parameter	Symbol	Conditions	Min.	Typ.	Max.	Unit
Power Supply						
Input supply voltage	V_{CC}		4		16	V
UVLO threshold	$UVLO_1$	Rising	3.55	3.8	3.95	V
	$UVLO_2$	Falling	3.3	3.5	3.65	
Quiescent current	I_{CC}	ENA=5V, IN1=IN2=L		1	3	mA
	I_{CC_STBY}	ENA=L, IN1 or IN2=5V	30	50	65	μA
	I_{CC_SLEEP}	ENA=L, IN1=IN2=L		1.5	3	μA
H-Bridge MOSFETs						
Body-diode forward voltage	V_F	$I_{OUT}=1\text{Amp}$		1	1.2	V
MOSFETs on resistance	R_{DS}	$I_{OUT}=1\text{A}$, HS+LS	1	1.2	1.5	Ω
Off-state output leakage current	I_{OFF}	ENA=L			10	μA
Output current	I_{OUT}			0.7	1	A
Control Logic						
Input logic low voltage	V_{IL}	IN1, IN2, ENA			0.6	V
Input logic high voltage	V_{IH}	IN1, IN2, ENA	2.2			V
Input pulldown resistance	R_{PD}	Logic input pins	80	100	120	$\text{K}\Omega$
Output dead time	T_{DT}		250	400	600	ns
Wake-up time	T_{RESET}	ENA high to outputs on	1	1.5	3	μs
Protection Circuitry						
Output current limiting	I_{OCL}		1.2			A
Thermal shutdown	TSD			170		°C
Thermal shutdown hysteresis	T_{HYS}			60		°C

PACKAGE INFORMATION

10PINS, SOP, 4.9mm × 6.0mm, PITCH=1.0mm

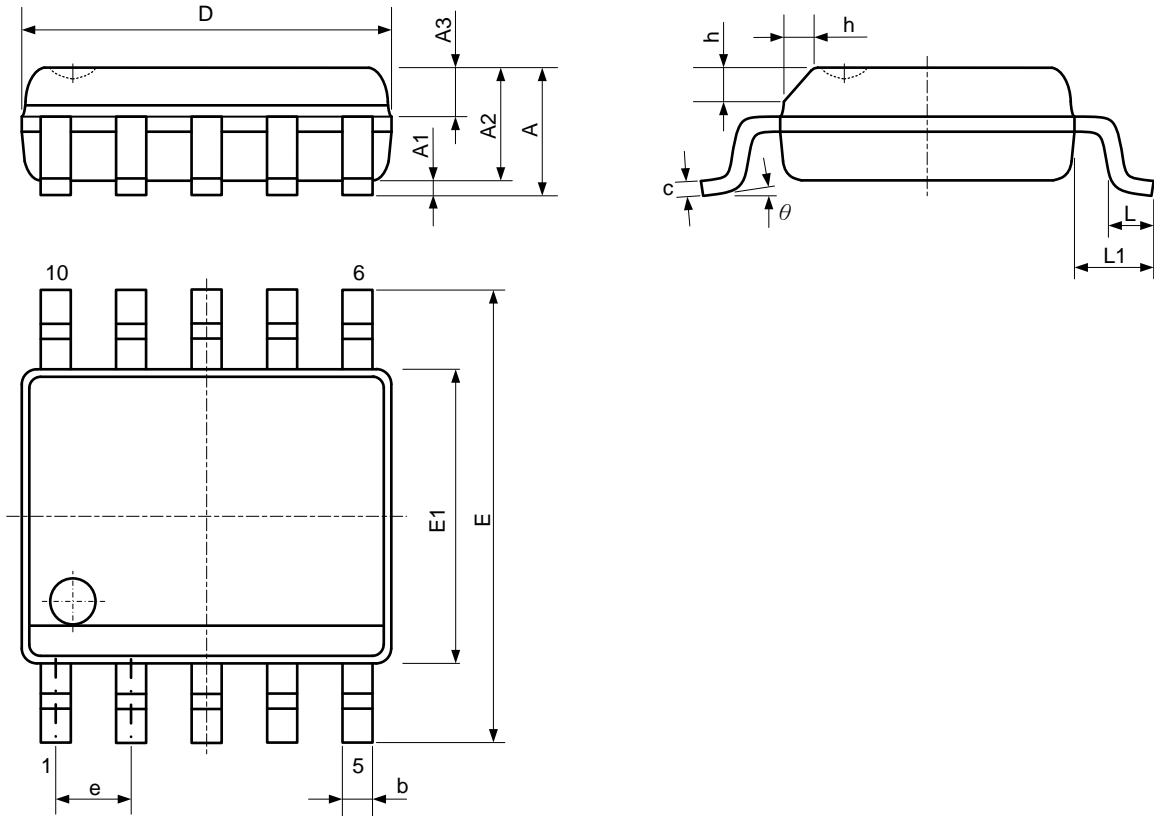

Symbol	Dimensions		
	Min.	Nom.	Max.
A			1.75
A1	0.10		0.25
A2	1.25		1.5
b	0.30		0.47
c	0.10		0.25
D	4.80	4.90	5.00
e	1.00 BSC		
E	5.80	6.00	6.20
E1	3.80	3.90	4.00
L	0.50		0.80
L1	1.05 REF		
h	0.25		0.5
θ	0°		8°

IMPORTANT NOTICE

Princeton Technology Corporation (PTC) reserves the right to make corrections, modifications, enhancements, improvements, and other changes to its products and to discontinue any product without notice at any time.

PTC cannot assume responsibility for use of any circuitry other than circuitry entirely embodied in a PTC product. No circuit patent licenses are implied.

Princeton Technology Corp.
2F, 233-1, Baociao Road,
Sindian Dist., New Taipei City 23145, Taiwan
Tel : 886-2-66296288
Fax: 886-2-29174598
<http://www.princeton.com.tw>