

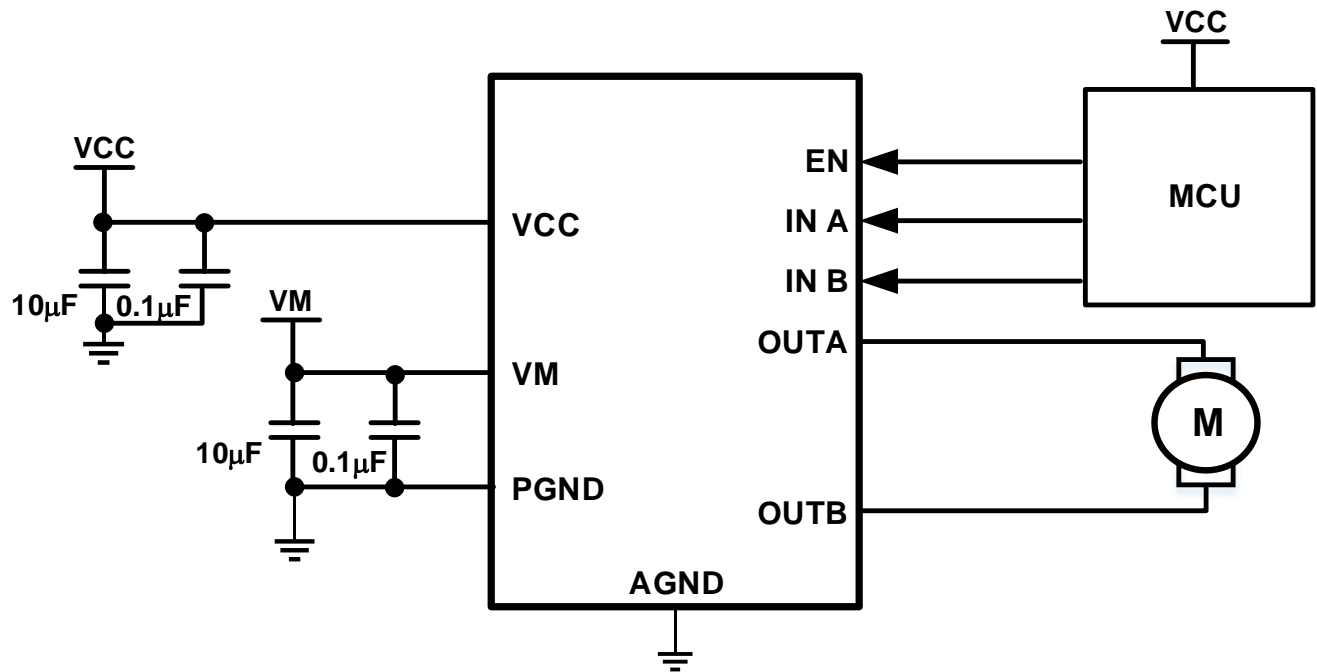

# APPLICATION CIRCUITS

## HSOP8



## ORDER INFORMATION

Valid Part Number	Package Type	Top Code
PT2476-HS	8 Pins, HSOP	PT2476-HS

## PIN CONFIGURATION

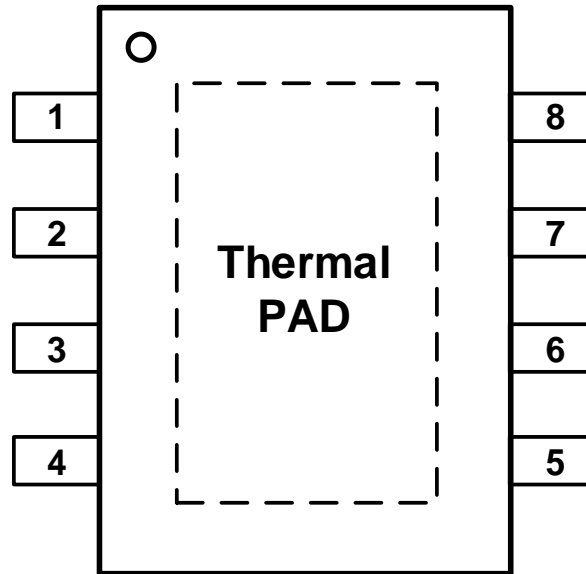

## PIN DESCRIPTION

Pin Name	I/O	Description	Pin No.
			HSOP8
AGND	GND	Logic GND	1
VCC	Power	Power supply for Logic circuit	2
VM	Power	Power supply for driver	3
OUTA	O	H-Bridge output terminal A of the driver	4
OUTB	O	H-Bridge output terminal B of the driver	5
INA	I	Control input	6
INB	I	Control input	7
EN	I	Logic Enable [300KΩ pull up for VCC]	8
PGND	GND	Power MOS GND	Thermal PAD

## FUNCTION DESCRIPTION

### INPUT/OUTPUT CONFIGURATION

#### INA, INB

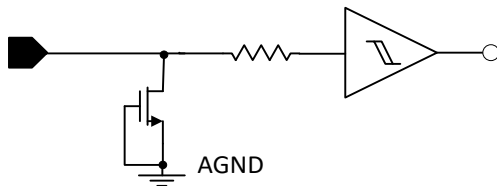

#### EN

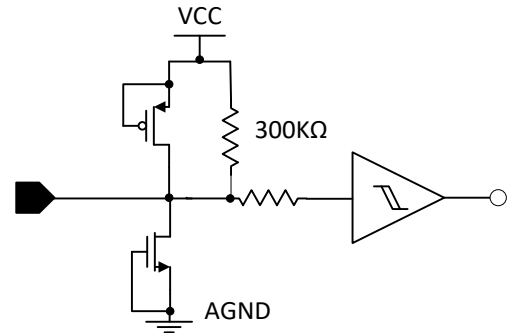

#### OUTA, OUTB

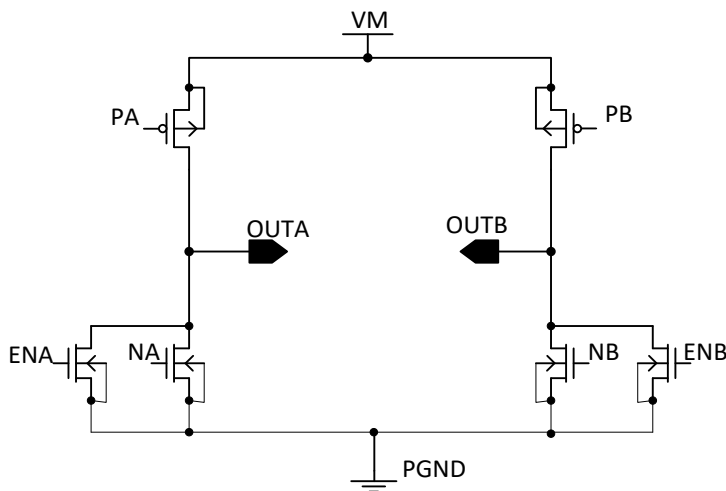

**Note:**

INA=INB=H and EN=H, OUTA and OUTB are low level in brake state, here the power NMOS NA and NB are on, the enable NMOS ENA and ENB are off. The NA and NB have the ability of sink current.

INA=INB=X and EN=L, OUTA and OUTB are low level in off state, here the power NMOS NA and NB are off, the enable NMOS ENA and ENB are on. The ENA and ENB only pull down the OUTA and OUTB, and they haven't the ability of sink current.

## INPUT-OUTPUT LOGIC TABLE

EN	Input Signal		Output Driver		Actuator status
	INA	INB	OUTA	OUTB	
H	L	L	Z	Z	Standby
H	L	H	L	H	Reverse
H	H	L	H	L	Forward
H	H	H	L	L	Brake
L	X	X	L	L	Off

## FUNCTION SEQUENCE

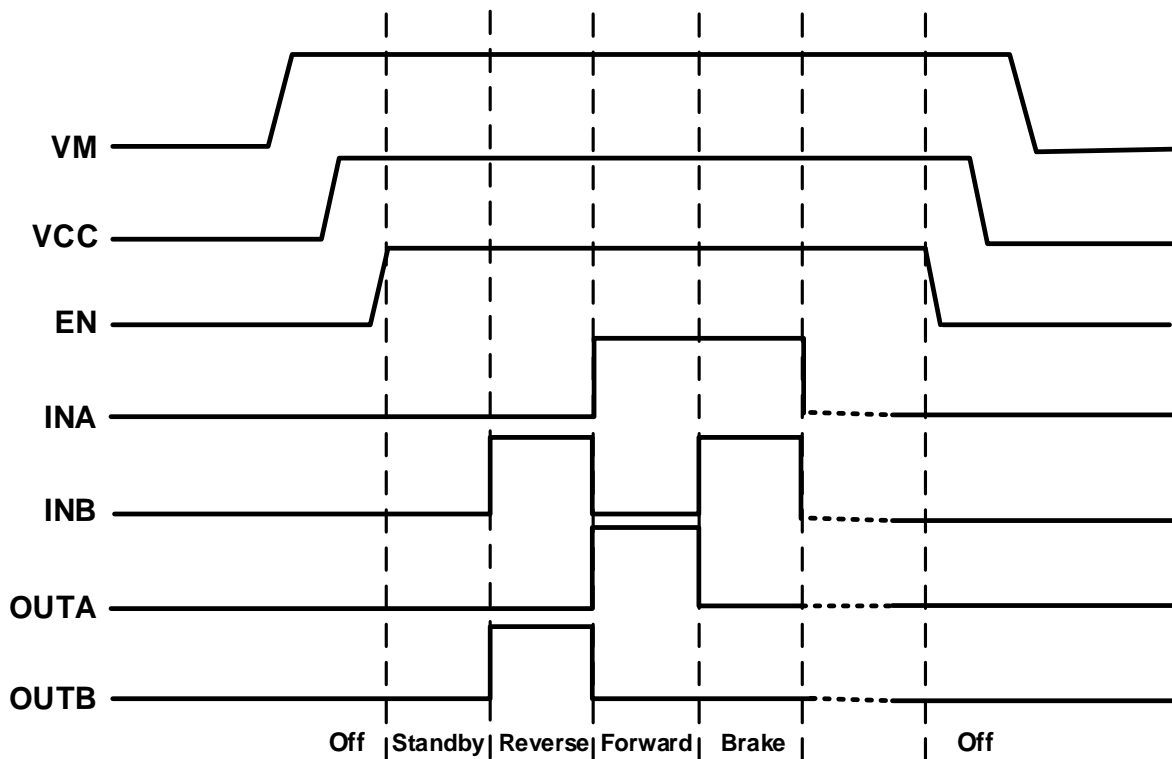

Note: VM & VCC power on have no timing sequence  
 VM & VCC power off have no timing sequence  
 EN power on have no timing sequence  
 EN power off have no timing sequence

## ***THERMAL SHUTDOWN (TSD) CIRCUIT***

The PT2476 includes a thermal shutdown circuit, which turns the output transistors off when the junction temperature ( $T_j$ ) exceeds  $175^{\circ}\text{C}$  (Typ.).

The output transistors are automatically turned on when  $T_j$  cools past the shutdown threshold, which is lowered by a hysteresis of  $30^{\circ}\text{C}$ .

$TSD = 175^{\circ}\text{C}$

$\Delta TSD = 30^{\circ}\text{C}$

\* In thermal shutdown mode, the circuits powered by VCC are work normal, and the circuits powered by VM are shut down.

## ***UNDER VOLTAGE LOCKOUT (UVLO) CIRCUIT***

The PT2476 includes an under voltage lockout circuit, which puts the output transistors in the high-impedance state when VCC decreases to  $2.13\text{V}$  (Typ.) or lower.

The output transistors are automatically turned on when VCC increases past the lockout threshold, which is raised to  $2.21\text{V}$  by a hysteresis of  $0.08\text{V}$ .

\* In UVLO shutdown mode, a part of circuits powered by VCC are work normal, and the circuits powered by VM are shut down.

## ***SHOOT-THROUGH CURRENT PROTECTION***

During Dead Time (Shoot through current circuit is operated.), Power MOS both of HI side and Low side are turned off. But in this time, internal parasitic diode is turned on according to current direction.

## ***OVER-CURRENT PROTECTION***

In the PT2476, a current monitor will protect the IC from damage due to output shorts. The internal Overcurrent Protection (OCP) has the following features:

If a short is detected, then the fault will be latched, and the IC will disable the outputs. The fault latch can only be cleared by reset EN pin or by cycling the power to VM.

## ABSOLUTE MAXIMUM RATINGS

Parameter	Symbol	Min.	Max.	Unit	Note
Supply voltage VCC	VCC	-0.5	6	V	-
Control input voltage	INA/INB/EN	-0.5	6	V	-
Supply voltage VM	VM	-0.5	22	V	-
H-Bridge output current DC	Iload_dc_MD	-	2.8	A	-
H-Bridge output current AC	Iload_peak_MD	-	5.0	A	Note1
Continuous power dissipation	Pd Ta=85°C	-	1083	mW	Note2
Operation temperature	Ta	-40	85	°C	-
Junction temperature	Tj	-	150	°C	-
Storage temperature	Tstg	-40	150	°C	-
Minimum ESD rating(HBM)	Vesd	2000	-	V	-
Minimum ESD rating(MM)	Vesd	200	-	V	-

Operation outside the Absolute Maximum Ratings may cause permanent device damage. These ratings are stress limits only, and functional operation of the device at these or any other conditions beyond those specified under Recommended Operating Conditions is not guaranteed. Operating outside the Recommended Operating Conditions but within the Absolute Maximum Ratings may impair device functionality, reliability, or longevity.

Notes:

1. Terminal OUTA,OUTB pulse with  $\leq 200\text{ms}$  :Duty 1%
2. Glass epoxy board : 4 layer circuit board,  $R_j=39^\circ\text{C}/\text{W}$   
 EP pin is connected to GND. (EP pin has 4 thermal VIA holes.)

## RECOMMENDED OPERATION CONDITIONS

Parameter	Symbol	Min.	Typ.	Max.	Unit
Supply voltage VCC	VCC	2.7	3.3	5.5	V
Control input voltage	INA/INB/EN	1.62	1.8/3.3	VCC	V
Supply voltage VM	VM	2	-	20	V
Logic input frequency	Fin	0	-	200	KHz
Logic input duty for frequency=200KHz (Ta=25°C, VCC=3.3V, VM=12V, Rload=50Ω)	Duty	6%	-	94%	%

Functional operation is guaranteed only within the Recommended Operating Conditions. Operation outside this range may result in degraded performance, reduced reliability, or shortened lifetime of the device.

# ELECTRICAL CHARACTERISTICS

 (Unless otherwise specified,  $T_a=25^{\circ}\text{C}$ ,  $V_{CC}=3.3\text{V}$ ,  $V_M=7.4\text{V}$ )

Parameter	Symbol	Conditions	Min.	Typ.	Max.	Unit
<b>VDET</b>						
VCC UVLO	VCDET_LV		1.90	2.13	2.50	V
<b>TSD (Note)</b>						
Thermal shut down temperature	TDET		-	175	-	$^{\circ}\text{C}$
Hysteresis	TDETHYS		-	30	-	$^{\circ}\text{C}$
<b>OCP</b>						
Over current protection trip level	IOCP			3.6		A
Over current deglitch time	ldgt			2		$\mu\text{S}$
<b>Power supply current</b>						
VM standby current1	IVM_NOPOW	$V_{CC}=L$	-	0.005	0.05	$\mu\text{A}$
VM standby current2	IVM_STBY	$EN=L$	-	0.005	0.05	$\mu\text{A}$
VCC work current	IVCC_WORK	$EN=H, INA=INB=L$	-	110	300	$\mu\text{A}$
VCC off current	IVCC_OFF	$EN=L$	-	11	30	$\mu\text{A}$
Operation circuit current	IVCC_PWM	$INA=200\text{KHz}, INB=H$	-	0.38	0.8	$\text{mA}$
<b>Driver</b>						
Output on resistance 1 (HSD or LSD)	RON1	$V_{CC}=3.3\text{V}, I_{OUT}=100\text{mA}$ $T_a=25^{\circ}\text{C}$	-	0.23	0.27	$\Omega$
Output on resistance 2 (HSD or LSD)	RON2	$V_{CC}=3.3\text{V}, I_{OUT}=1.0\text{A}$ $T_a=25^{\circ}\text{C} (T_j=65^{\circ}\text{C})$	-	0.245	0.29	$\Omega$
Output on resistance 3 (HSD or LSD)	RON3	$V_{CC}=3.3\text{V}, I_{OUT}=1.0\text{A}$ $T_a=85^{\circ}\text{C} (T_j=125^{\circ}\text{C})$	-	0.295	0.35	$\Omega$
Diode forward voltage	VF_MD	$IF=100\text{mA}$	-	0.7	1.2	V
<b>Control terminal</b>						
H level input voltage (INA, INB, EN)	VIH		$0.7 \times V_{CC}$	-	-	V
L level input voltage (INA, INB, EN)	VIL		-	-	$0.3 \times V_{CC}$	V
H level input current (INA, INB)	IIH1	$EN=H \text{ or } L$	-	-	1	$\mu\text{A}$
L level input current (INA, INB)	IIL1	$EN=H \text{ or } L$	-	-	1	$\mu\text{A}$
H level input current (EN)	IIH1		-	-	1	$\mu\text{A}$
L level input current (EN)	IIL1		-	11	30	$\mu\text{A}$
<b>Full Swing</b>						
Turn on time 1	TfONH	$V_{CC}=3.3\text{V}, V_M=7.4\text{V}$ $I_{OUT}=500\text{mA}$ , Output state: Forward $\rightarrow$ Reverse. Refer to Fig.1	-	0.42	1.0	$\mu\text{s}$
Turn off time 1	TfOFFH		-	0.11	0.5	$\mu\text{s}$
Output rise time 1	Tfr		-	0.09	1.0	$\mu\text{s}$
Output fall time 1	Tff		-	0.04	0.5	$\mu\text{s}$
Turn on time 2	TrONH	$V_{CC}=3.3\text{V}, V_M=7.4\text{V}$ $I_{OUT}=500\text{mA}$ , Output state: Reverse $\rightarrow$ Forward. Refer to Fig.1	-	0.38	1.0	$\mu\text{s}$
Turn off time 2	TrOFFH		-	0.11	0.5	$\mu\text{s}$
Output rise time 2	Trr		-	0.09	1.0	$\mu\text{s}$
Output fall time 2	Trf		-	0.04	0.5	$\mu\text{s}$

Note: OUTA and OUTB are Hi-Z (off state) at thermal shut down.

# SWITCHING CHARACTERISTICS WAVEFORM

## SWITCHING WAVEFORM

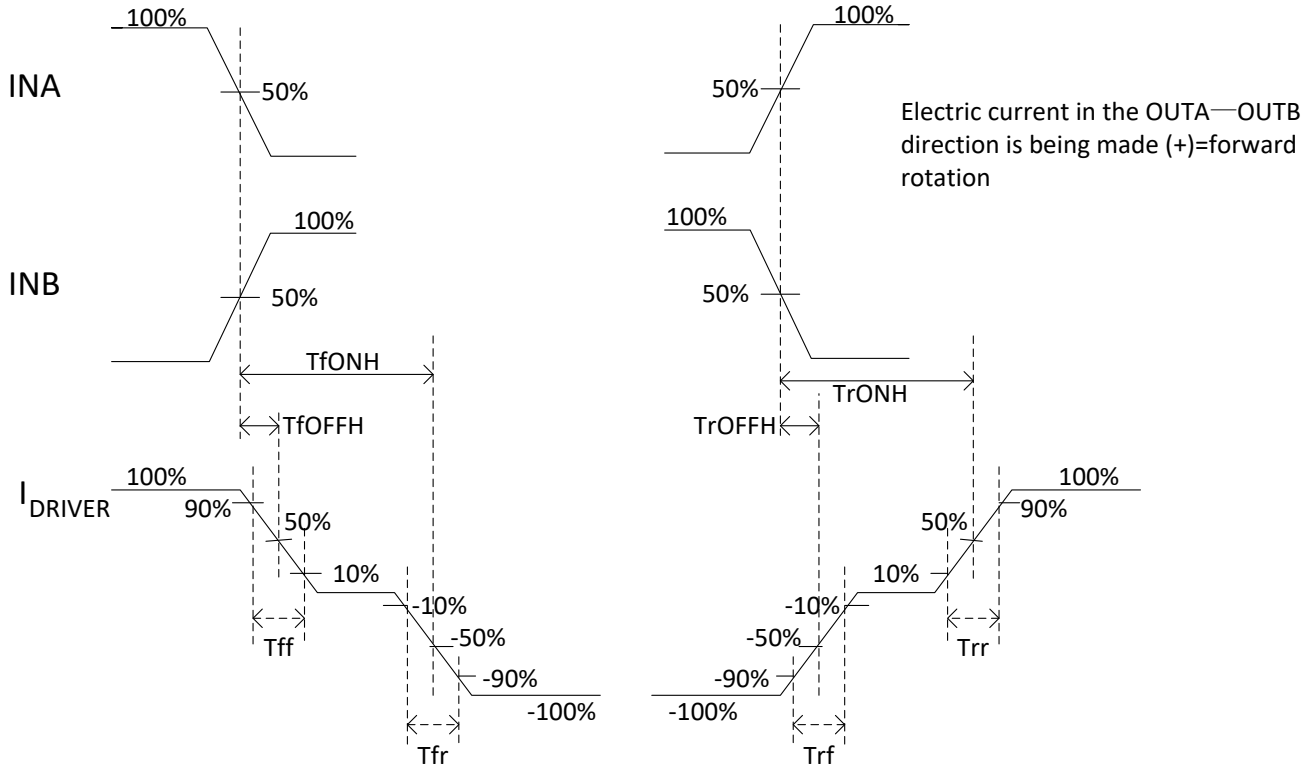
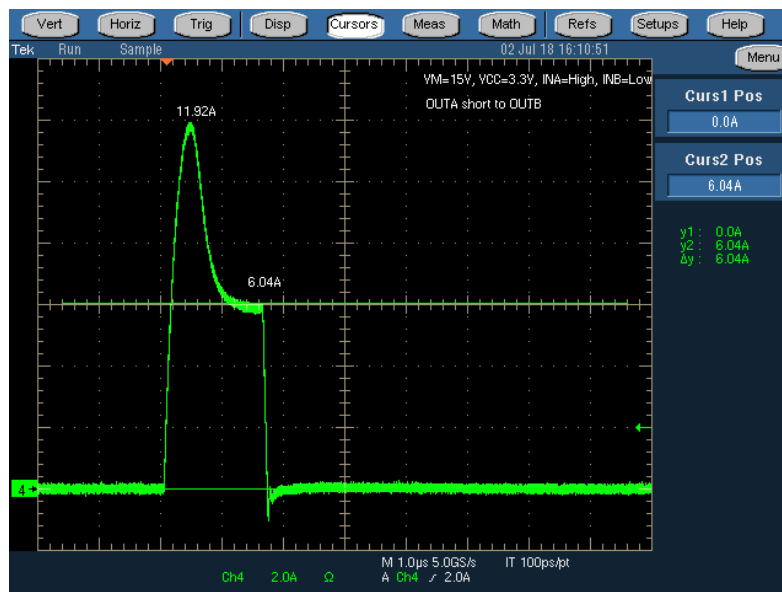
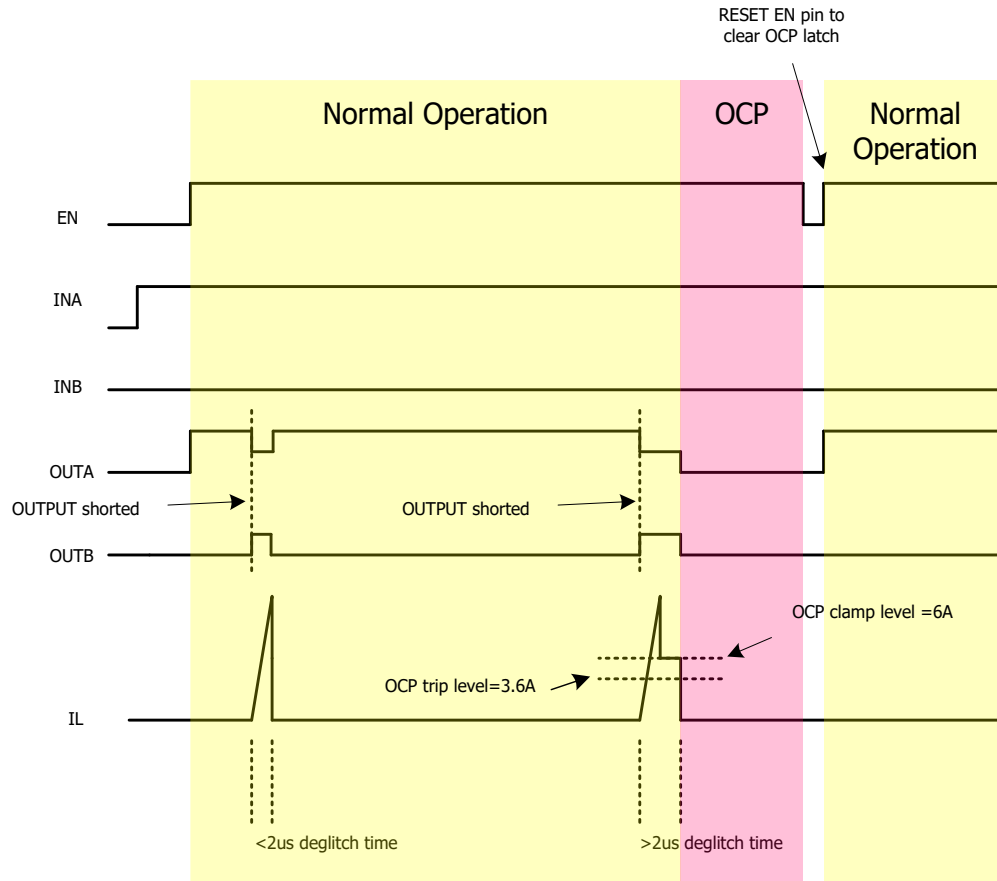

Fig.1 switching characteristics waveform

# OCF CHARACTERISTICS WAVEFORM

## OUTPUT SHORTED WAVEFORM



# PACKAGE INFORMATION

## 8-PIN, HSOP

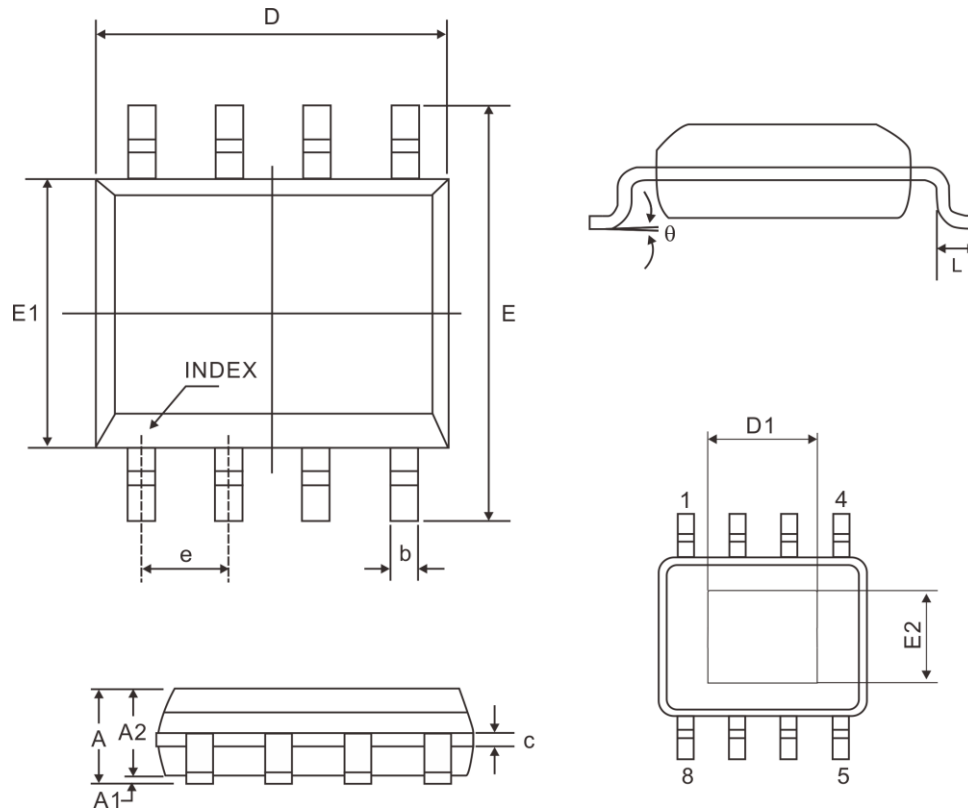

Symbol	Dimensions(mm)		
	Min.	Nom.	Max.
A	-	-	1.70
A1	0.00	-	0.15
A2	1.25	-	-
b	0.31	-	0.51
c	0.10	-	0.25
e	1.27 BSC		
D	4.90 BSC		
D1	2.81	-	3.30
E	6.00 BSC		
E1	3.90 BSC		
E2	2.05	-	2.41
L	0.40	0.60	1.27
$\theta$	0°	-	8°

Notes:

1. Refer to JEDEC MS-012 BA.
2. All dimensions are in millimeter.
3. D1 and E2 refer to supplier spec. The JEDEC MS-012BA classify D1 and E2 minimum value are 1.5mm and 1.0mm.

## **IMPORTANT NOTICE**

Princeton Technology Corporation (PTC) reserves the right to make corrections, modifications, enhancements, improvements, and other changes to its products and to discontinue any product without notice at any time.

PTC cannot assume responsibility for use of any circuitry other than circuitry entirely embodied in a PTC product. No circuit patent licenses are implied.

Princeton Technology Corp.  
2F, 233-1, Baociao Road,  
Sindian Dist., New Taipei City 23145, Taiwan  
Tel : 886-2-66296288  
Fax: 886-2-29174598  
<http://www.princeton.com.tw>