

## DESCRIPTION

PT2509 is a full-bridge driver with build-in driving pattern for the swing head motor application. It integrates the over temperature protection, short-circuit protection, and under voltage protection. With one EN control pin, the PT2509 will deliver 50Hz PWM waveform to drive the AC synchronous motor. Besides the 50Hz pattern, a clock signal can also feed to EN pin to operate with required frequency. PT2509 with package in SOP8.

## FEATURES

- Full-bridge driver with fixed pattern for AC synchronous motor
- Short Circuit Protection (SCP)
- Over Temperature Protection (OTP)
- Under Voltage Lock-Out protection (UVLO)
- Sinewave or trapezoid-like driving waveform
- 40Hz to 100Hz adjustable driving frequency

## APPLICATIONS

- Fan with swing head motor

## BLOCK DIAGRAM

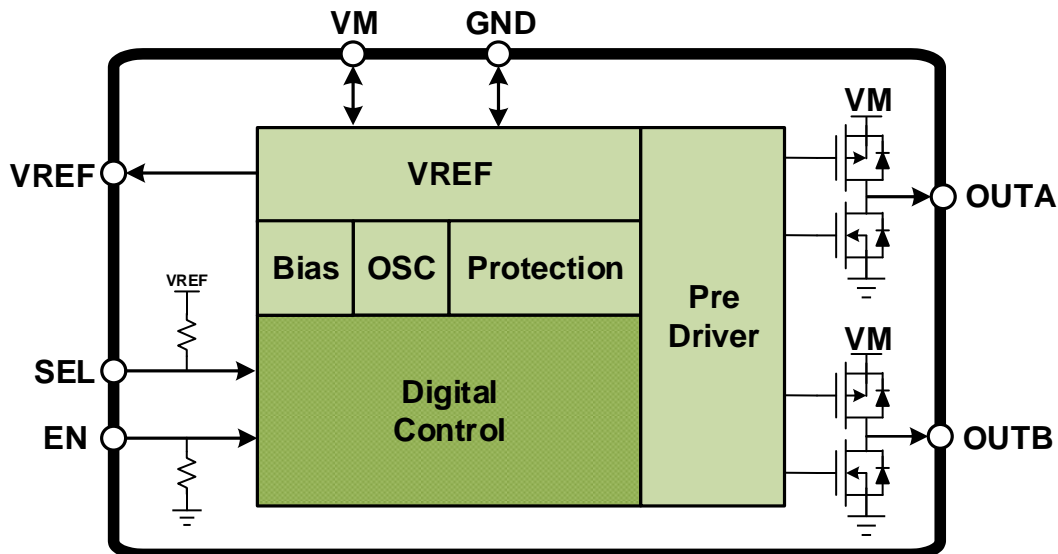

## ORDER INFORMATION

Part Number	Package	Top Logo
PT2509-S	8-PIN, SOP	PT2509-S

## APPLICATION BLOCK DIAGRAM

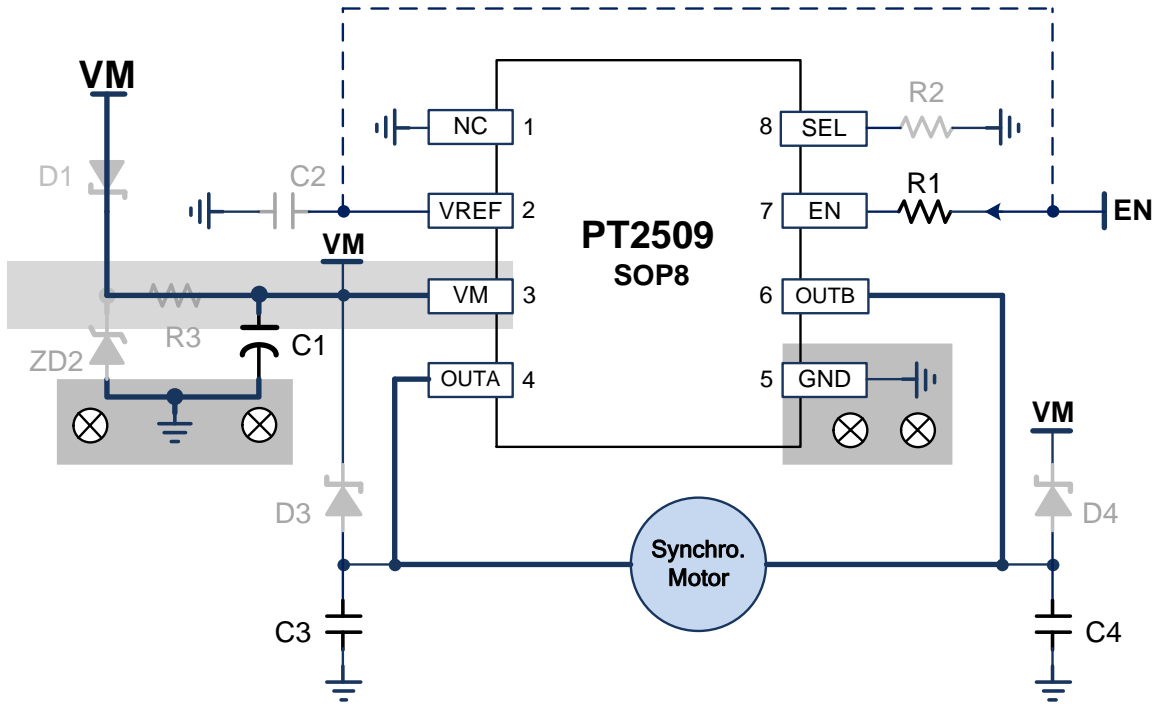

Part	Value	Unit	Description
R1	1K	Ω	Protection resistor for EN input
R2	1K	Ω	Setting resistor for SEL input(option)
R3	0~1	Ω	Filter resistor over the VM input(option) *its selection need care about power rating and heat generation
C1	1u~10u/50V	F	Filter capacitor over VM (Electrolytic or Tantalum Capacitors)
C2	NC~100p	F	Filter capacitor for VREF(option) *<100pF will not influence to circuit response
C3/C4	10n/50V	F	Surge voltage suppressing capacitor over motor terminal
D1	>50V/2A	V	Reverse supply voltage protection(option) *its selection need care about voltage drop and heat generation
ZD2	27V/1A	V	Surge voltage suppressing over VM(option)
D3/D4	>50V/1A	V	Surge voltage suppressing diode over motor terminal(option). *1N5819 Schottky type reacts faster

## PIN ASSIGNMENT

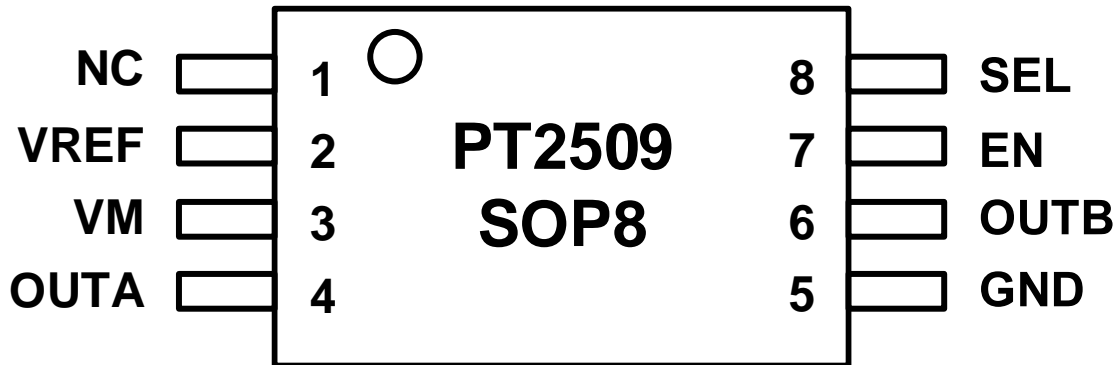

## PIN DESCRIPTION

Pin Name	I/O/P	Description	Pin No.
			8 Pin
NC		No connection(or connect to GND)	1
VREF	P	+5V reference voltage for internal use	2
VM	P	Power supply	3
OUTA	O	Full-bridge driver output A	4
GND	P	Signal ground	5
OUTB	O	Full-bridge driver output B	6
EN	I	It can apply with DC or clock input DC input: 0V to disable, 5V to enable and default driving frequency is 50Hz Clock input: 40Hz to 100Hz square wave input to set the driving frequency EN is internal pull-down to GND via 100KΩ and recommend in series an 1KΩ resistor to it	7
SEL	I	Driving mode selection 5V to sinewave(default) 0V to trapezoid wave SEL is internal pull-up to VREF via 100KΩ	8

## PIN EQUIVALENT CIRCUIT

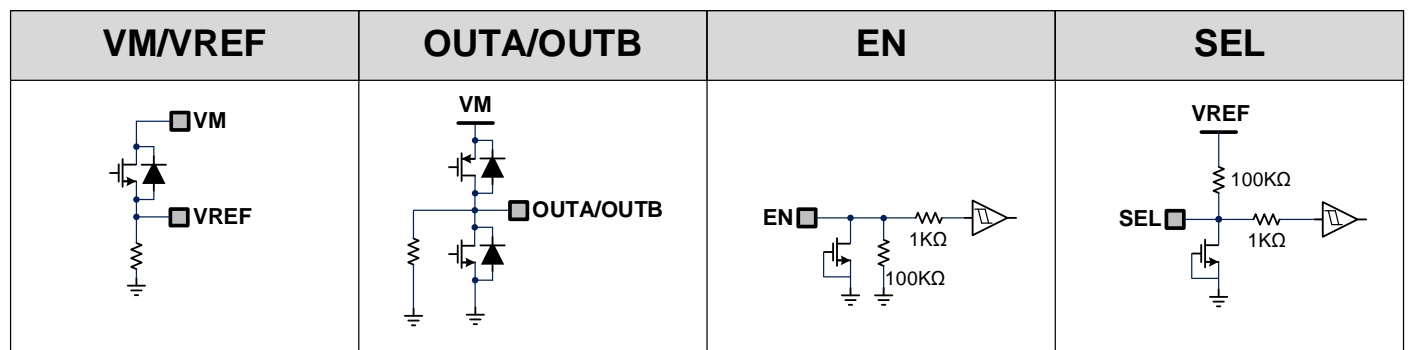

## FUNCTION DESCRIPTION

For FAN application, the swing head function is worked with AC synchronous motor mostly. In the past, the required 50 Hz driving waveform and output driver is implemented with MCU coding and discrete components. In PT2509, it provides the driving waveform with hardware logic without MCU. It also integrates a full-bridge driver with under-voltage lockout protection(UVLO), over-temperature protection(OTP) and short-circuit protection(SCP) to enhance the shortcoming with discrete components.

### Power Supply

PT2509 is designed to work with single supply voltage  $V_M$  and a  $10\mu\text{F}$  shunt capacitor is used to stabilize  $V_M$ .  $V_{REF}$  is internal generated reference voltage (about 4.8V) to supply the bias circuit, clock generator, protection circuit and digital circuit. Due to its limited current delivery,  $V_{REF}$  is not recommended to supply external circuit and an  $100\text{pF}$  bypass capacitor is required.

### Clock Command

For AC power with frequency 50 Hz, PT2509 is designed to output PWM signal in that frequency. During the driving, a 50HZ sinewave current waveform is shown over the coil; For customer need drive with different frequency, a clock signal (40 to 100Hz with duty cycle 40~60%) can apply to EN, then output PWM signal will follow the clock frequency

### Over Temperature Protection

PT2509 with over temperature protection(OTP) inside and its operation range is  $150^\circ\text{C} / 120^\circ\text{C}$ . When the IC internal temperature reach  $150^\circ\text{C}$ , OTP triggered and it will stop output PWM signal to motor. When the temperature cold down to  $120^\circ\text{C}$ , the OTP is released and it will continue to send PWM signal to motor. Beware, the OTP threshold temperature is referred to IC inside, the surface temperature of IC is a little different.

### Short-Circuit Protection

When the coil of motor is shorted, PT2509 detect it and provide short-circuit protection(SCP) for it. During the SCP, the PWM signal to coil will be stop immediately (full-bridge driver output floating) and wait for a short period(100ms) to detect again. If the SCP condition is removed, PT2509 will back to normal operation mode. If the SCP still happened, it continues the process – wait and detect.

### Driving Waveform Selection, SEL

Pin SEL is used to select the trapezoidal-wave or sinewave driving. The trapezoidal-wave driving has larger driving capability than sinewave but larger noise and vibration will be generated. The default setting for P2509 will use sinewave driving. Pin SEL is pull-up to  $V_{REF}$  via  $100\text{K}\Omega$  internally. The figure below is the voltage waveform of SEL=H & SEL=L OUTA/B without load.

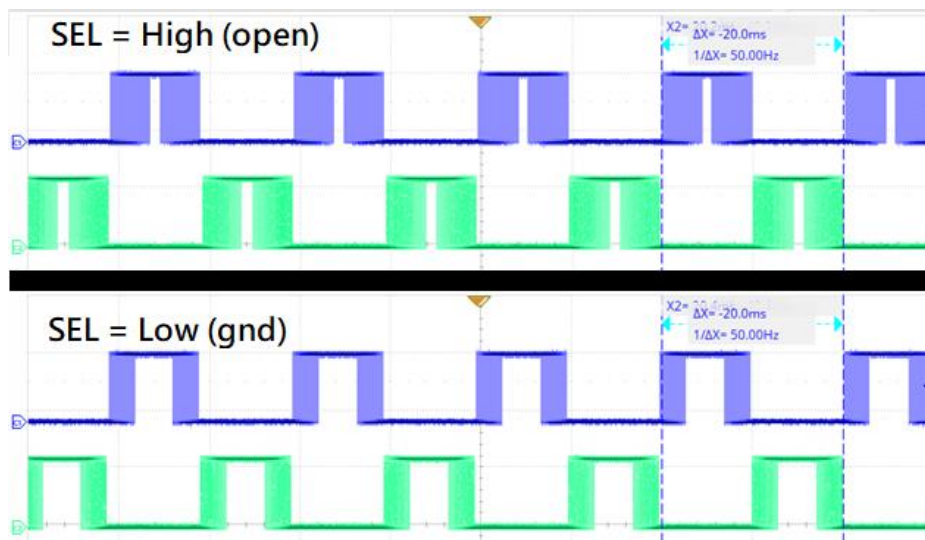

## ABSOLUTE MAXIMUM RATINGS

Parameter	Symbol	Min.	Max.	Unit
Supply voltage range	$V_M$	8	32	V
Input pin withstand voltage	$V_{IN}$	-0.3	6	V
Output driving current	$I_{OUT}$		400*	mA
Operating temperature range	$T_A$	-40	+105	°C
Storage temperature range	$T_{STG}$	-40	+150	°C

\* IC no breakdown

\*over well air circulated environment

## ELECTRICAL CHARACTERISTICS

Nominal conditions:  $V_M=24.0V$ ,  $GND=0V$ ,  $T_A = +27^{\circ}C$ .

Parameter	Symbol	Conditions	Min.	Typ.	Max.	Unit
Supply voltage	$V_M$		8	24	28	V
Current consumption	$I_M$	For chip operation only and the current to motor is not counted		4.6		mA
Reference voltage	$V_{VREF}$	With internal load only		4.8		V
Output stage resistance	$R_{ON}$	High side+low side MOS resistance		5		$\Omega$
Logic input high level	$V_{IH}$	Apply to EN, SEL	2.5		5	V
Logic input low level	$V_{IL}$	Apply to EN, SEL			1	V
Clock command	$F_{CLK}$	Apply to EN	40		100	Hz
Over-temperature protection trigger	$T_{OTPTR}$	Temperature increasing, design target		150		°C
Over-temperature protection release	$T_{OTPREL}$	Temperature decreasing, design target		120		°C

# PACKAGE INFORMATION

8 Pins, SOP

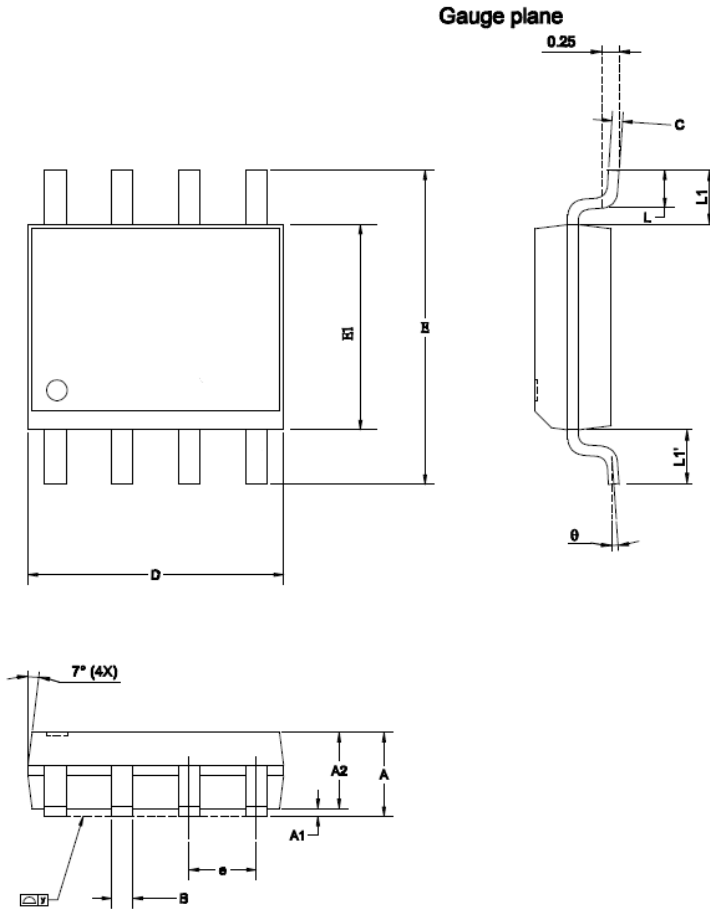

Symbol	Min.	Nom.	Max.
A	1.40	1.50	1.60
A1	0.00	—	0.10
A2	—	1.45	—
B	0.33	—	0.51
C	0.19	—	0.25
D	4.80	—	5.00
E1	3.80	3.90	4.00
e	—	1.27	—
E	5.80	6.00	6.20
L	0.40	—	1.27
y	—	—	0.1
$\theta$	0°	—	8°
$ L1 - L1' $	—	—	0.12
L1	1.04 REF		

Notes:

1. Refer to JEDEC MS-012
2. Unit: mm

**IMPORTANT NOTICE**

Princeton Technology Corporation (PTC) reserves the right to make corrections, modifications, enhancements, improvements, and other changes to its products and to discontinue any product without notice at any time.

PTC cannot assume responsibility for use of any circuitry other than circuitry entirely embodied in a PTC product. No circuit patent licenses are implied.

Princeton Technology Corp.  
2F, 233-1, Baociao Road,  
Sindian Dist., New Taipei City 23145, Taiwan  
Tel: 886-2-66296288  
Fax: 886-2-29174598  
<http://www.princeton.com.tw>