

DESCRIPTION

The PT5126A is 1 Full-On Drive H-Bridge channel with two different packages. The driver features wide range operating from 2V to 24V and low power consumption by fast switching speed.

APPLICATIONS

- Toys
- Lens for DSLR
- Auto icemaker or dumper drive for refrigerator
- HV bi-direction DC Motor
- Intelligent electronic lock

FEATURES

- It is low consumption by BCD process adoption
- Two different small packages: HSOP8, SOP8
- Wide power-supply voltage range:
 - Control (VCC): 2.7V ~ 5.5V
 - Motor (VM): 2.0V ~ 24V
- High DC output current: Max.=2.8A
- Ultra low RDSON(TOP+BOT):
 - 0.51ΩTYP@25°C, 1A for HSOP8;
 - 0.64ΩTYP@25°C, 1A for SOP8
- Low current consumption when power-down: <0.05μA @25°C
- PWM control, Max. input frequency: 200KHz.
- Operating temperature range: -40 ~ +85°C
- Charge-pump less
- Shoot-through current protection
- Built-in protection circuits
 - Under voltage lock out
 - Thermal shut down

BLOCK DIAGRAM

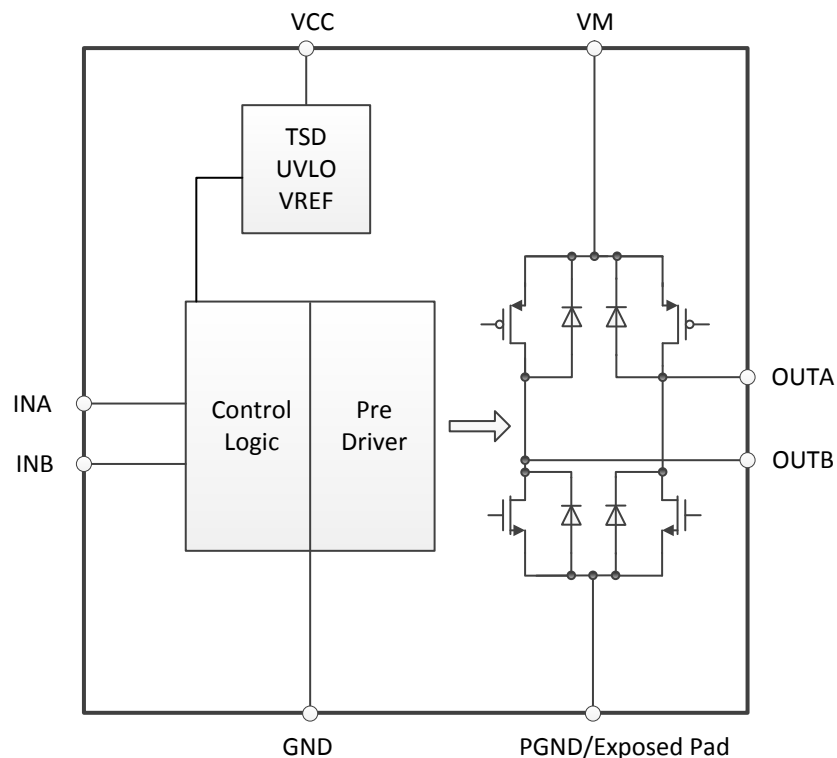

APPLICATION CIRCUITS

SOP8/HSOP8

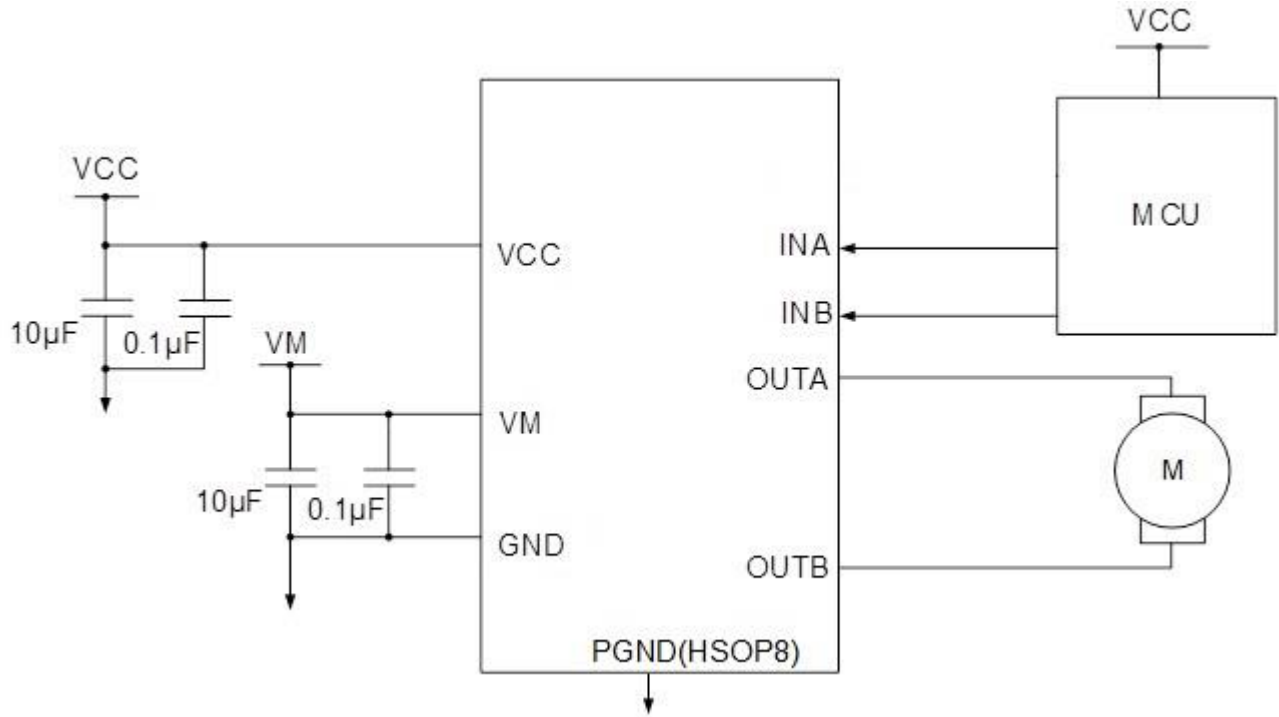

ORDER INFORMATION

Valid Part Number	Package Type	Top Code
PT5126A-S	8 pins, SOP	PT5126A-S
PT5126A-H	8 pins, HSOP	PT5126A-H

PIN CONFIGURATION

SOP8

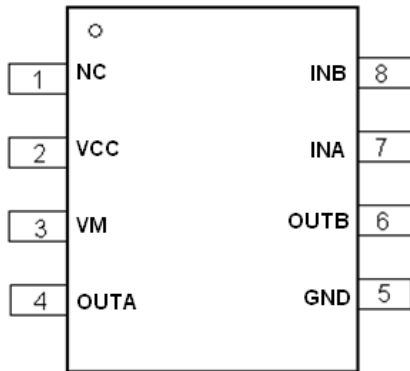

HSOP8

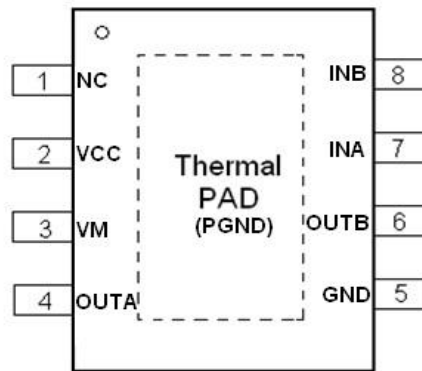

PIN DESCRIPTION

Pin Name	I/O	Description	Pin No.	
			SOP8	HSOP8
NC	-	NC pin	1	1
GND	GND	Ground	5	5
VCC	Power	Power supply for logic circuit	2	2
VM	Power	Power supply for driver	3	3
OUTA	O	H-Bridge output terminal A of the driver	4	4
OUTB	O	H-Bridge output terminal B of the driver	6	6
INA	I	Control input	7	7
INB	I	Control input	8	8
PGND	GND	Power MOS GND	-	Thermal PAD

INPUT/OUTPUT CONFIGURATION

INA, INB

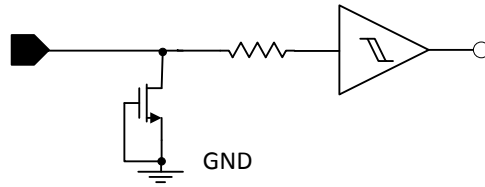

OUTA, OUTB

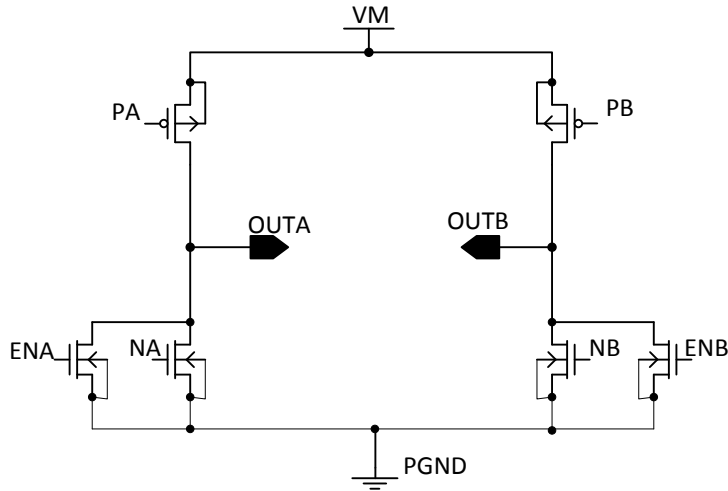

Note:

INA=INB=H, OUTA and OUTB are low level in brake state, here the power NMOS NA and NB are on, the enable NMOS ENA and ENB are off. The NA and NB have the ability of sink current.

INA=INB=L, OUTA and OUTB are low level in off state, here the power NMOS NA and NB are off, the enable NMOS ENA and ENB are on. The ENA and ENB only pull down the OUTA and OUTB, and they haven't the ability of sink current.

FUNCTION TABLE

INPUT-OUTPUT LOGIC TABLE

Input Signal		Output Driver		Actuator status
INA	INB	OUTA	OUTB	
L	L	Z	Z	Stand-by(Stop)
L	H	L	H	Reverse
H	L	H	L	Forward
H	H	L	L	Brake

FUNCTION SEQUENCE

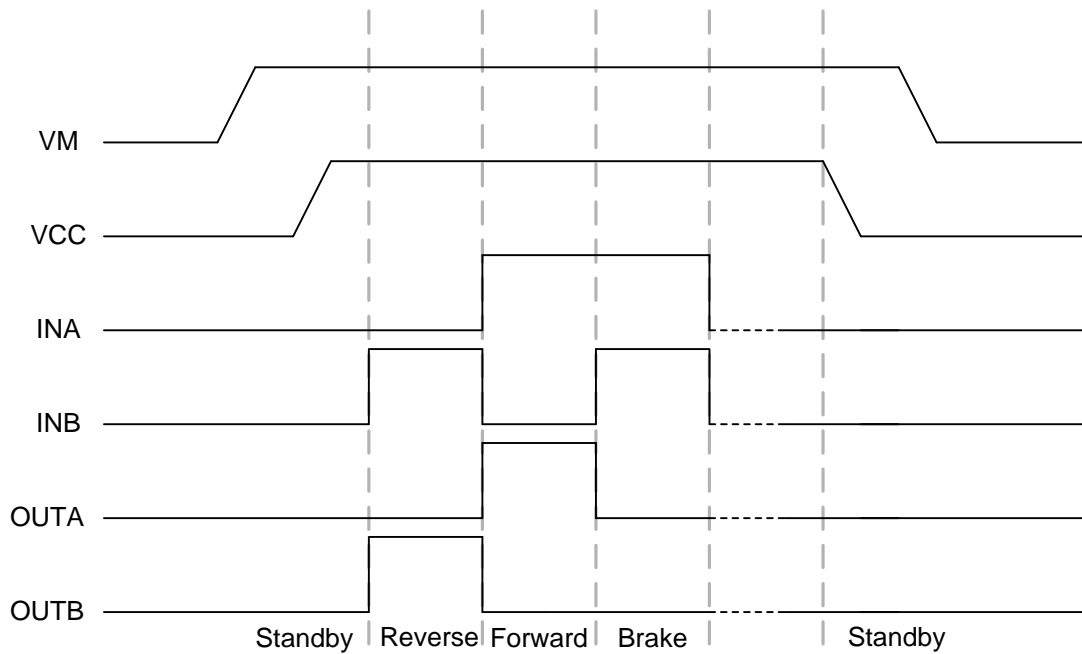

Note: VM & VCC power on have no timing sequence
VM & VCC power off have no timing sequence

PROTECTION FUNCTION

THERMAL SHUTDOWN (TSD) CIRCUIT

The PT5126A includes a thermal shutdown circuit, which turns the output transistors off when the junction temperature (T_j) exceeds 175°C (typ.).

The output transistors are automatically turned on when T_j cools past the shutdown threshold, which is lowered by a hysteresis of 30°C.

TSD = 175°C

Δ TSD = 30°C

* In thermal shutdown mode, the circuits powered by VCC are work normal, and the circuits powered by VM are shut down.

UNDER VOLTAGE LOCKOUT (UVLO) CIRCUIT

The PT5126A includes an under voltage lockout circuit, which puts the output transistors in the high-impedance state when VCC decreases to 2.13V (typ.) or lower.

The output transistors are automatically turned on when VCC increases past the lockout threshold, which is raised to 2.21 V by a hysteresis of 0.08 V.

* In UVLO shutdown mode, a part of circuits powered by VCC are work normal, and the circuits powered by VM are shut down.

SHOOT-THROUGH CURRENT PROTECTION

During Dead Time (Shoot through current circuit is operated.), Power MOS both of HI side and Low side are turned off. But in this time, internal parasitic diode is turned on according to current direction.

ABSOLUTE MAXIMUM RATINGS

Parameter	Symbol	Min	Max	Unit	Note	
Supply voltage	VCC	-0.5	6	V		
Control input voltage	INA/INB	-0.5	6	V		
Supply voltage	VM	-0.5	26	V		
H-Bridge output current DC	Iload_dc_MD(HSOP8)	-	2.8	A		
	Iload_dc_MD(SOP8)	-	1.3	A		
H-Bridge output current AC	Iload_peak_MD(HSOP8)	-	4.8	A	Note1	
	Iload_peak_MD(SOP8)	-	7.5	A	Note2	
Continuous power dissipation	Pd Ta=25°C (HSOP8)	-	3	W	Note4	
	Pd Ta=85°C (HSOP8)	-	1.6	W		
	Pd Ta=25°C (SOP8)	-	1.1	W	Note5	
	Pd Ta=85°C (SOP8)	-	0.58	W		
Operation temperature	Ta	-40	85	°C		
Junction temperature	Tj	-	150	°C		
Storage temperature	Tstg	-40	150	°C		
Minimum ESD rating	HBM	Vesd	2000	-	V	
	MM		200	-	V	

Notes:

- Terminal OUTA,OUTB pulse with $\leq 200\text{ms}$:Duty 5%
- Terminal OUTA,OUTB pulse with $\leq 200\text{ms}$:Duty 1%
- Maximum power dissipation is a function of Tj(max), Rja, and TA. The maximum allowable power dissipation at any allowable ambient temperature is $PD = (Tj(\text{max}) - TA) / Rja$. Operating at the absolute maximum Tj of 150° C can affect reliability.
- The package thermal impedance for HSOP8 is calculated in accordance with JEDEC, 2S2P test PCB, Rja=41°C/W
- The package thermal impedance for SOP8 is calculated in accordance with JEDEC, 2S2P test PCB, Rja=113.5°C/W

RECOMMENDED OPERATION CONDITIONS

Parameter	Symbol	Min	Typ.	Max	Unit
Supply voltage	VCC	2.7	3.3	5.5	V
Control input voltage	INA/INB	1.62	1.8/3.3	VCC	V
Supply voltage	VM	2	-	24	V
Logic input frequency	Fin	0	-	200	KHz
Logic input duty for frequency=200KHz (Ta=25°C, VCC=3.3V, VM=12V, Rload=50Ω, Output state: Forward↔Reverse)	Duty	6%	-	94%	%

ELECTRICAL CHARACTERISTICS

(Unless otherwise specified, Ta=25°C, VCC=3.3V, VM=7.4V)

Parameter	Symbol	Conditions	Min.	Typ.	Max.	Unit
VDET						
VCC UVLO	VCDDET_LV		1.90	2.13	2.50	V
TSD (Note)						
Thermal shut down temperature	TDET		-	175	-	°C
Hysteresis	TDETHYS		-	30	-	°C
Power Supply Current						
VM standby current1	IVM_NOPOW	VCC=L	-	0.005	0.05	μA
VM standby current2	IVM_STBY	INA=INB=L	-	0.005	0.05	μA
VCC work current	IVCC_WORK	INA=H, INB=L	-	130	300	μA
Operation circuit current	IVCC_PWM	INA=200KHz, INB=H	-	0.38	0.8	mA
Driver						
Output on resistance 1 (HSD or LSD)	RON1(HSOP8)	VCC=3.3V, IOUT=100mA Ta=25°C	-	0.25	0.27	Ω
	RON1(SOP8)		-	0.31	0.35	
Output on resistance 2 (HSD or LSD)	RON2(HSOP8)	VCC=3.3V, IOUT=1.0A Ta=25°C (Tj=65°C)	-	0.255	0.29	Ω
	RON2(SOP8)		-	0.32	0.40	
Output on resistance 3 (HSD or LSD)	RON3(HSOP8)	VCC=3.3V, IOUT=1.0A Ta=85°C (Tj=125°C)	-	0.295	0.35	Ω
	RON3(SOP8)		-	0.35	0.45	
Diode forward voltage	VF_MD	IF=100mA	-	0.7	1.2	V
Control Terminal						
H level input voltage(INA, INB)	VIH		0.7xVCC	-	-	V
L level input voltage (INA, INB)	VIL		-	-	0.3xVCC	V
H level input current (INA, INB)	IIH1		-	-	1	μA
L level input current (INA, INB)	IIL1		-	-	1	μA
Full Swing						
Turn on time 1	TfONH	VCC=3.3V, VM=7.4V IOUT=500mA, Output state: Forward→Reverse. Refer to Fig.1	-	0.42	1.0	μs
Turn off time 1	TfOFFH		-	0.11	0.5	μs
Output rise time 1	Tfr		-	0.09	1.0	μs
Output fall time 1	Tff		-	0.04	0.5	μs
Turn on time 2	TrONH	VCC=3.3V, VM=7.4V IOUT=500mA, Output state: Reverse→Forward. Refer to Fig.1	-	0.38	1.0	μs
Turn off time 2	TrOFFH		-	0.11	0.5	μs
Output rise time 2	Trr		-	0.09	1.0	μs
Output fall time 2	Trf		-	0.04	0.5	μs
Turn on time 1	TfONH	VCC=3.3V, VM=7.4V IOUT=500mA, Output state: STBY→Forward/Reverse. Refer to Fig.2	-	2.10	10	μs
Output rise time 1	Tfr		-	0.09	1.0	μs
Turn off time 1	TfOFFH	VCC=3.3V, VM=7.4V IOUT=500mA, Output state: Forward/Reverse→STBY Refer to Fig.2	-	0.11	0.5	μs
Output fall time 1	Tff		-	0.04	0.5	μs

Note: OUTA and OUTB are Hi-Z (off state) at thermal shut down.

SWITCHING CHARACTERISTICS WAVEFORM

SWITCHING WAVEFORM

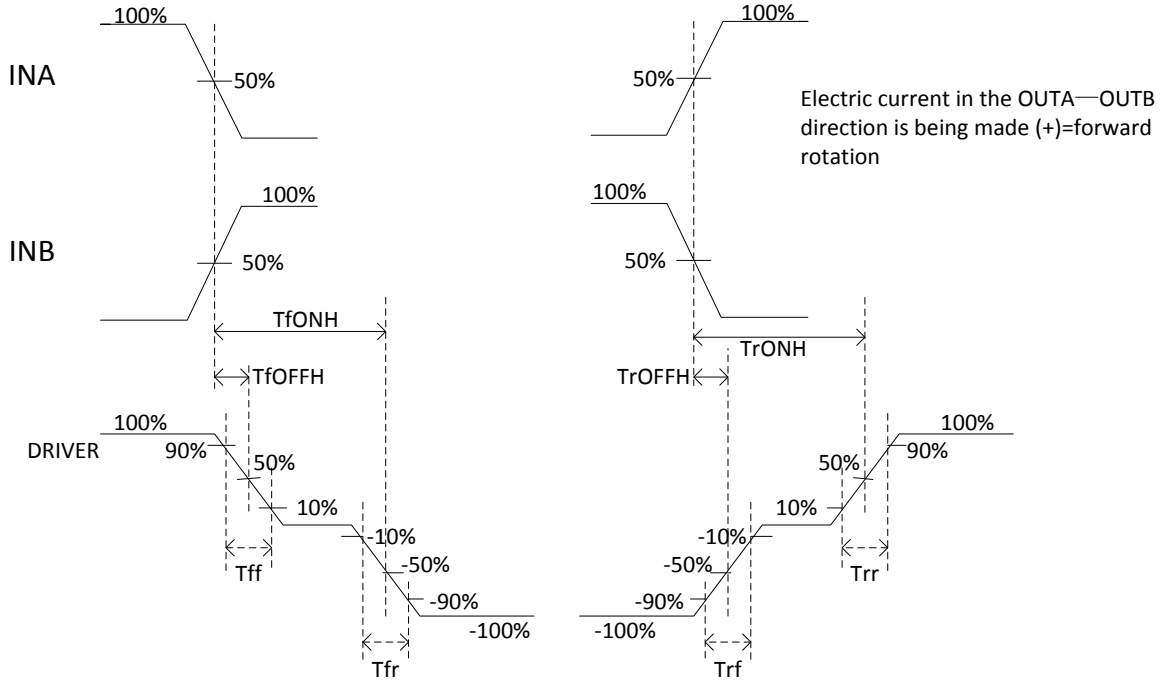

Fig.1 switching characteristics waveform

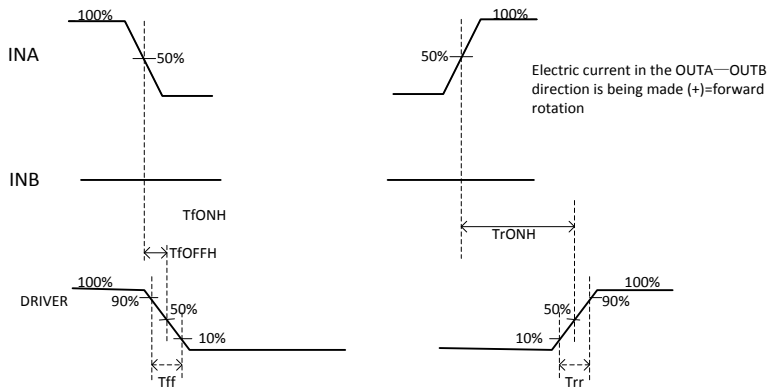
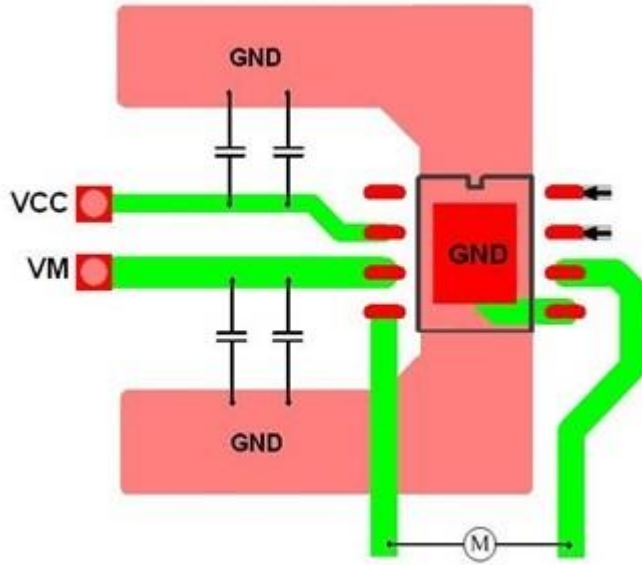

Fig.2 switching characteristics waveform

PCB LAYOUT

8-PIN, HSOP



8-PIN, SOP

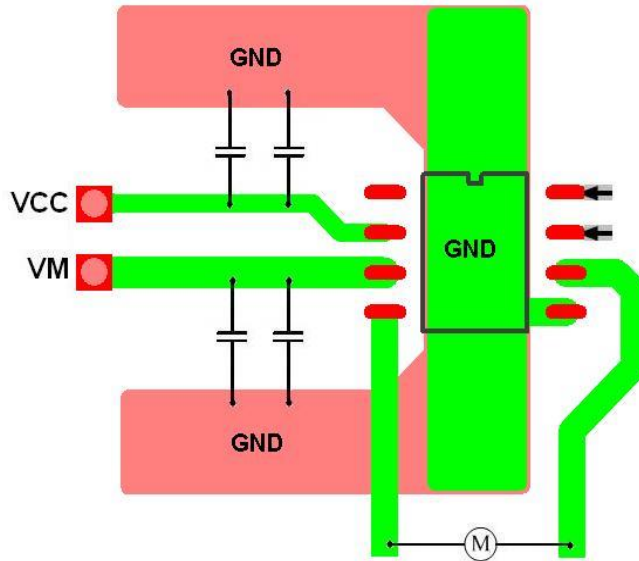

PACKAGE INFORMATION

8 PINS, HSOP

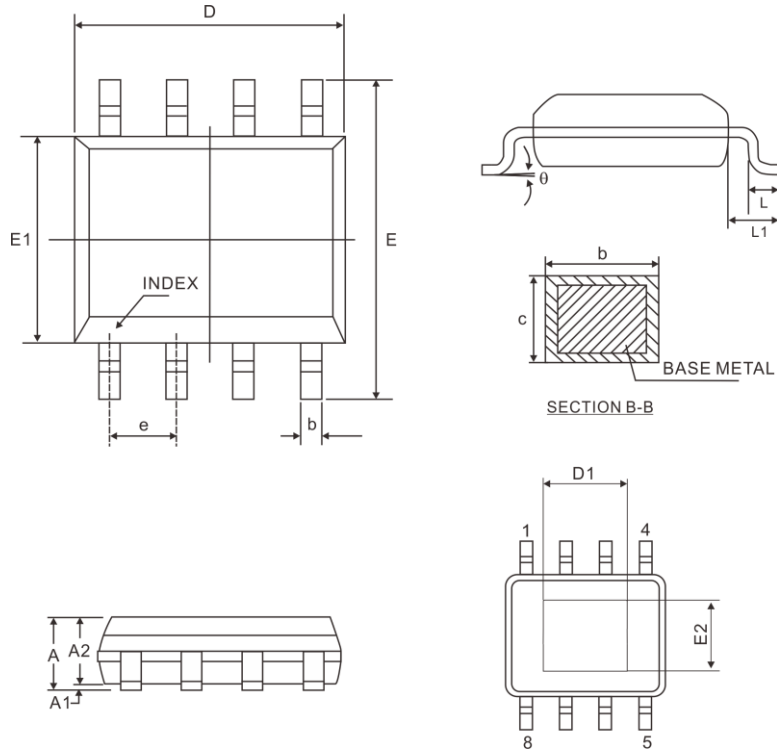

Symbol	Dimensions(mm)		
	Min.	Nom.	Max.
A	-	-	1.70
A1	0.00	-	0.15
A2	1.25	-	-
b	0.31	-	0.51
c	0.10	-	0.25
e	1.27 BSC		
D	4.90 BSC		
D1	2.81	-	3.30
E	6.00 BSC		
E1	3.90 BSC		
E2	2.05	-	2.41
L	0.40	0.60	1.27
θ	0°	-	8°

Notes:

1. Refer to JEDEC MS-012 BA
2. All dimensions are in millimeter.

8 PINS, SOP

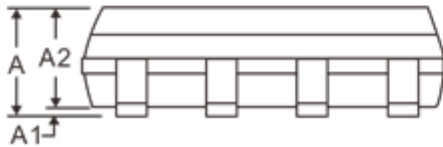
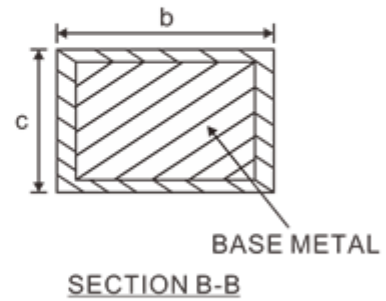
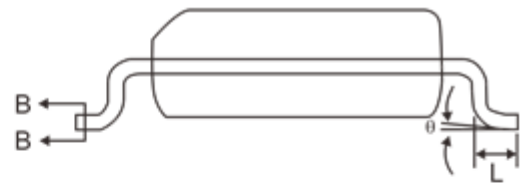
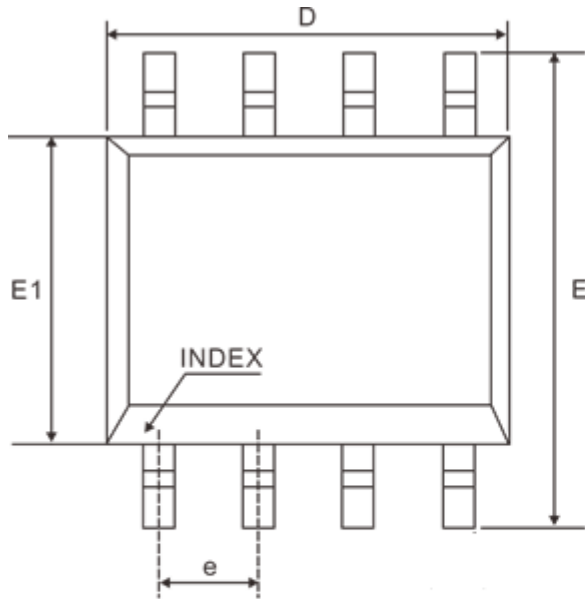

Symbol	Dimensions		
	Min.	Nom.	Max.
A	-	-	1.70
A1	0.00	-	0.15
A2	1.30	1.40	1.50
b	0.39	-	0.48
c	0.21	-	0.25
e	1.27 BSC		
D	4.90 BSC		
E	6.00 BSC		
E1	3.90 BSC		
L	0.40	-	1.27
L1	1.04 REF		
θ	0°	-	8°

Notes:

1. Refer to JEDEC MS-012 AA
2. All dimensions are in millimeter.

IMPORTANT NOTICE

Princeton Technology Corporation (PTC) reserves the right to make corrections, modifications, enhancements, improvements, and other changes to its products and to discontinue any product without notice at any time.

PTC cannot assume responsibility for use of any circuitry other than circuitry entirely embodied in a PTC product. No circuit patent licenses are implied.

Princeton Technology Corp.
2F, 233-1, Baociao Road,
Sindian Dist., New Taipei City 23145, Taiwan
Tel: 886-2-66296288
Fax: 886-2-29174598
<http://www.princeton.com.tw>