

## DESCRIPTION

These devices consist of two independent, high gain, internally frequency-compensated operational amplifiers designed operate from a single supply over a wide range of voltages. Operation from split supplies also is possible if the difference between the two supplies is 3V to 32V, and  $V_{CC}$  is at least 1.5V more positive than the input common-mode voltage, the low supply-current drain is independent of the magnitude of the power supply voltage.

## FEATURES

- Two internally compensated OP amps
- Internally frequency compensated for unity gain
- Short circuit protection
- Wide power supply range:  $3V_{DC}$  to  $32V_{DC}$  (Single supply)
- Input common-mode voltage range includes ground
- Large output voltage swing:  $0V_{DC}$  to  $V_{CC}-1.5V_{DC}$

## APPLICATIONS

- Electronic products
- Power supply
- Remote controller
- Consuming products

## BLOCK DIAGRAM

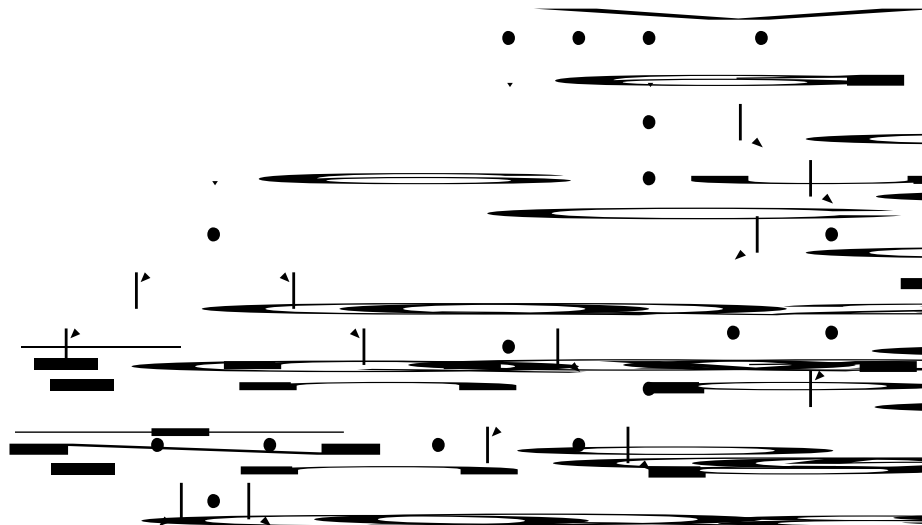

# APPLICATION CIRCUIT

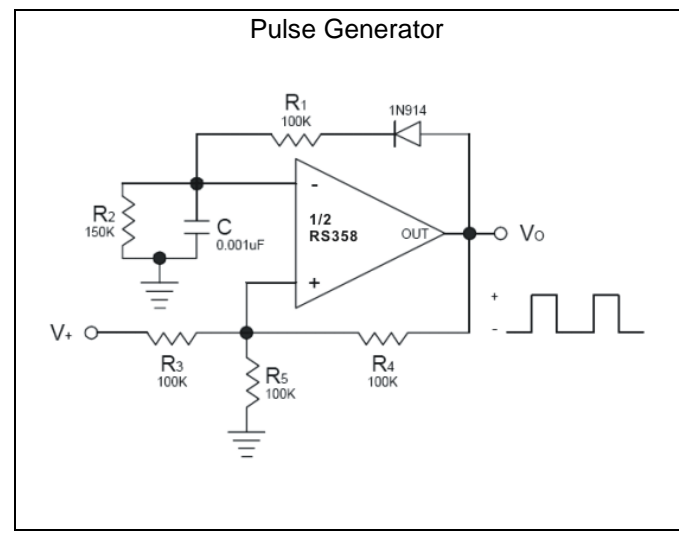
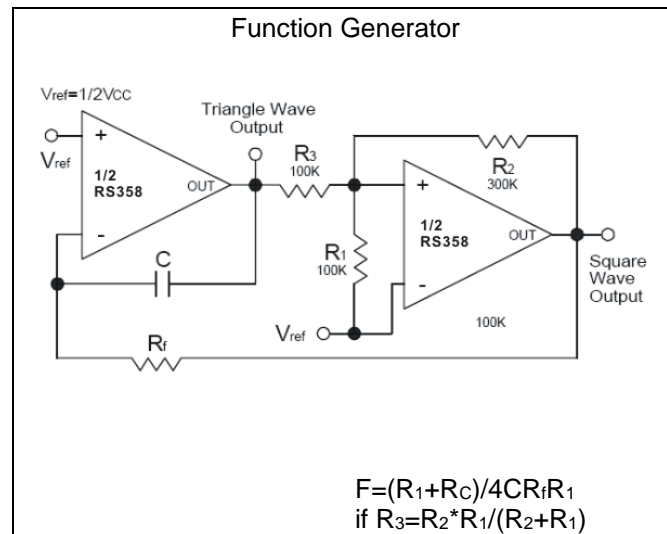
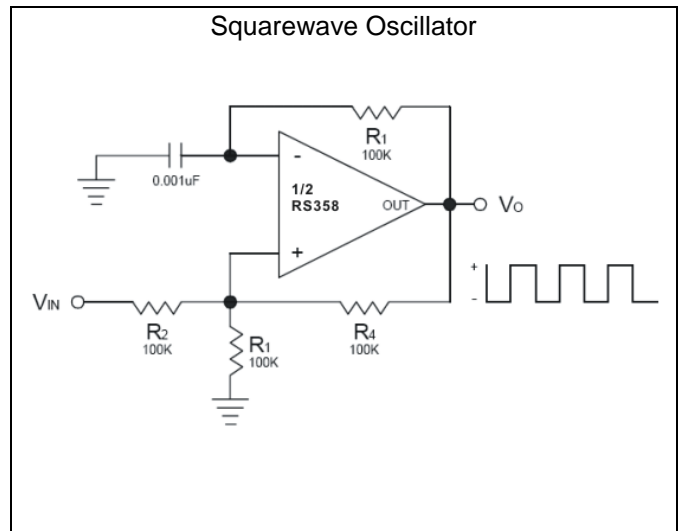
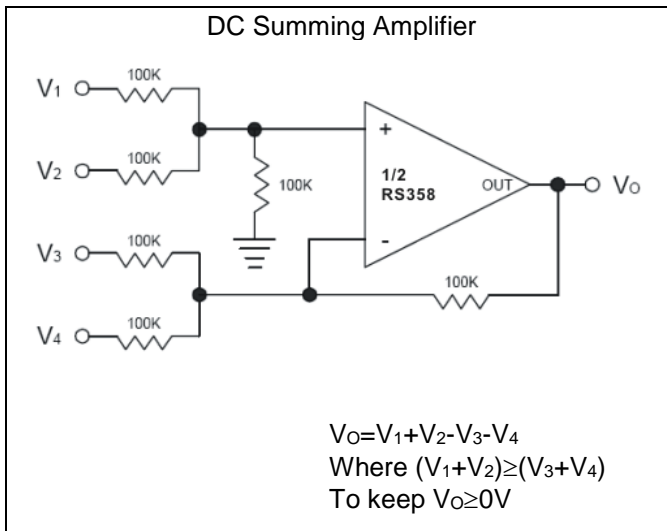
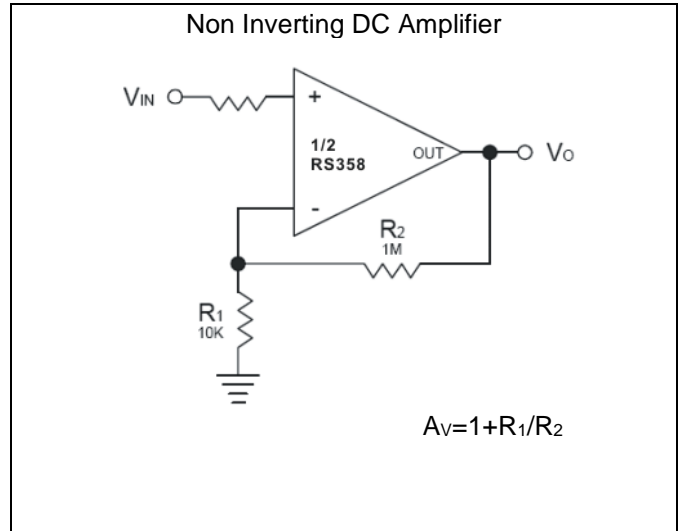
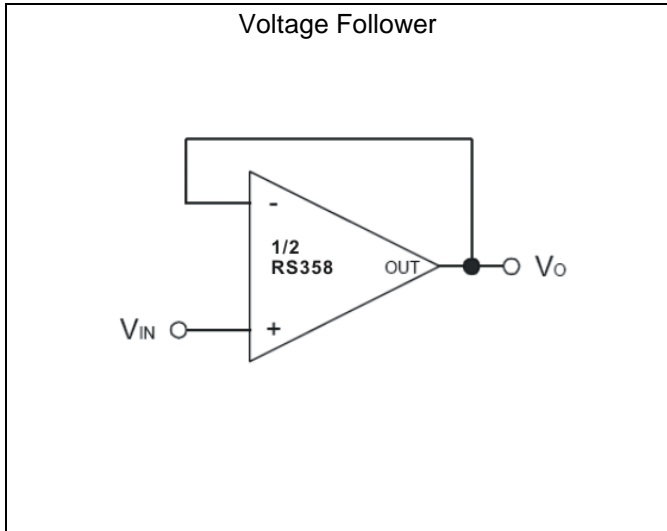

# APPLICATION CIRCUIT

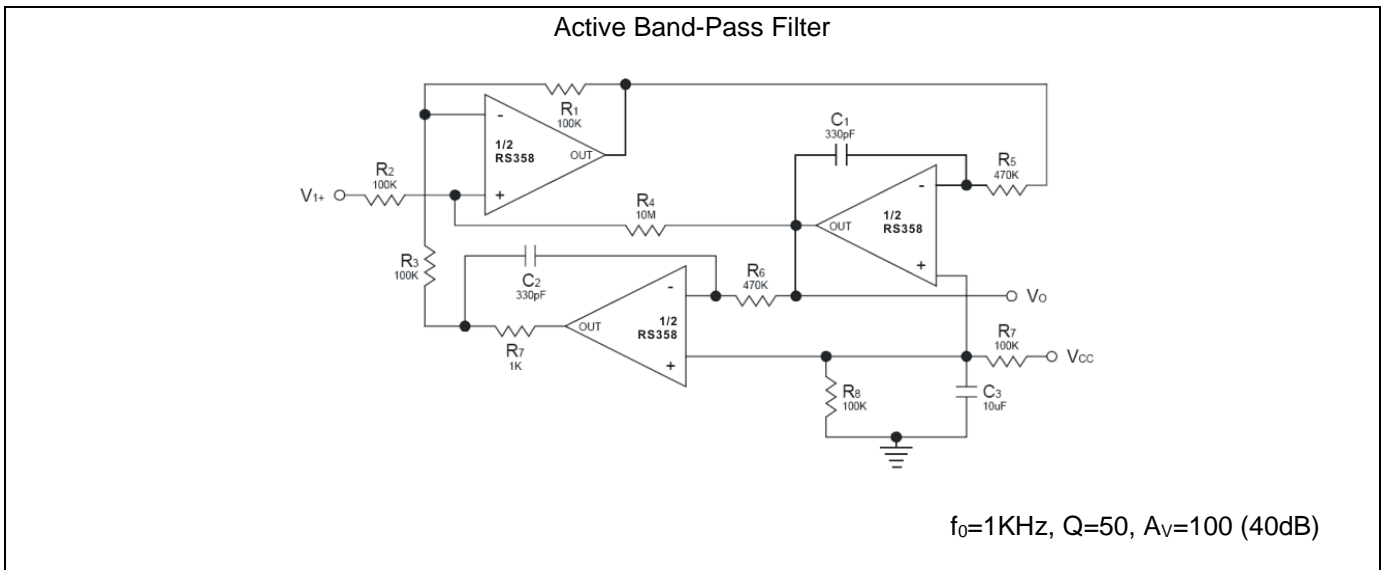
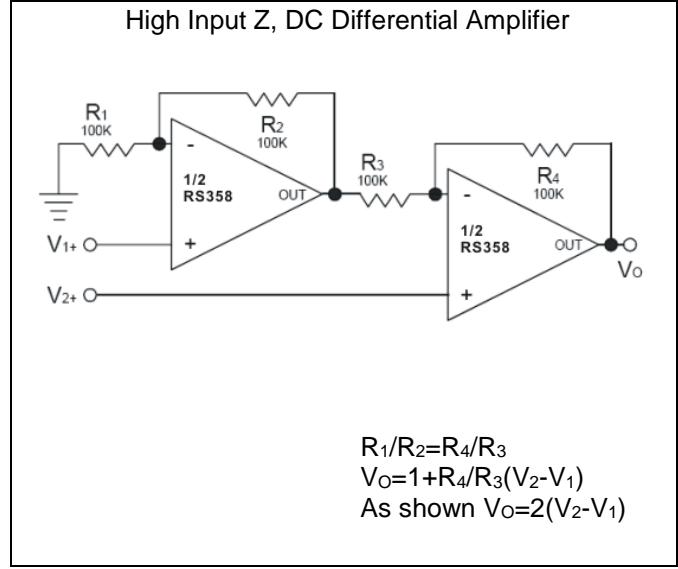
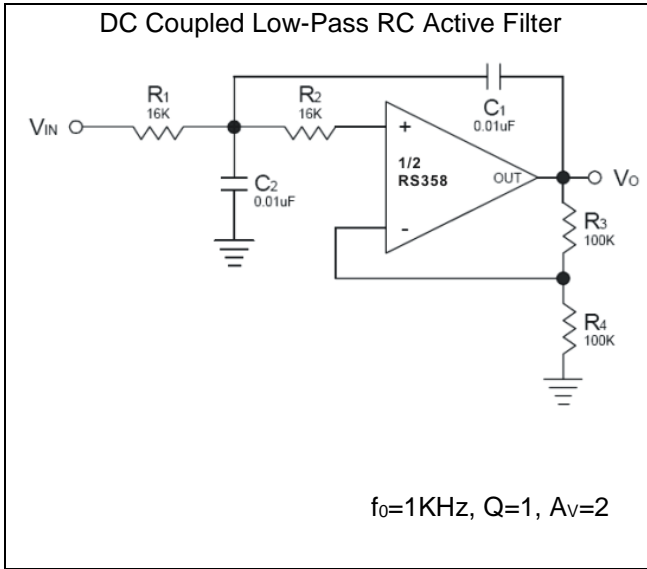

## ORDER INFORMATION

Part Number	Package Type
RS358S	8-Pin, SOP, 150mil

## PIN CONFIGURATION

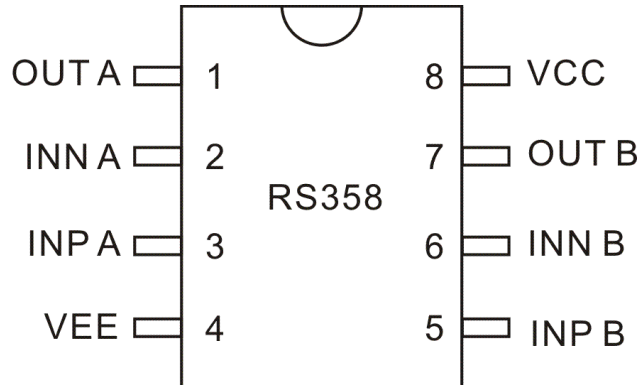

## PIN DESCRIPTION

Pin Name	Description	Pin No.
OUT A	Output A	1
INN A	Inverting input A (-)	2
INP A	Non inverting input A (+)	3
VEE	Connect to GND or negative voltage.	4
INP B	Non inverting input B (+)	5
INN B	Inverting input B (-)	6
OUT B	Output B	7
VCC	Supply voltage	8

# CHARACTERISTIC CURVES

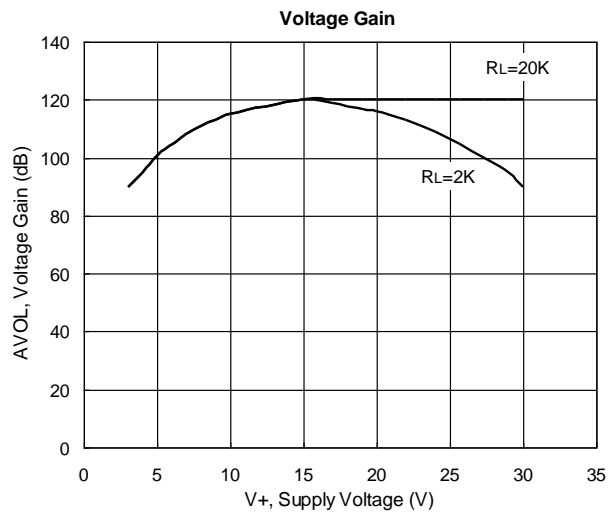
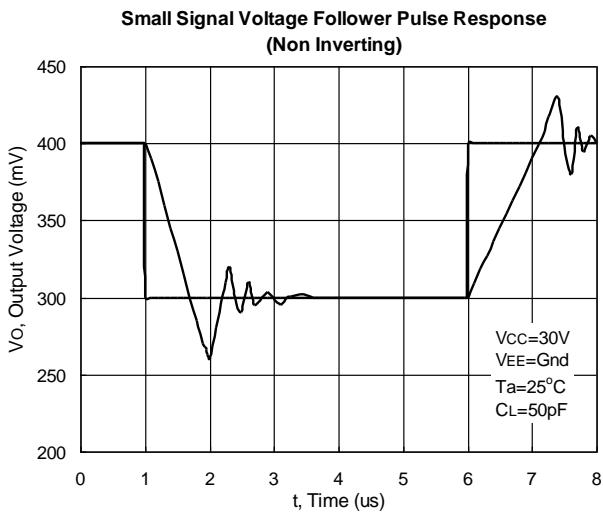
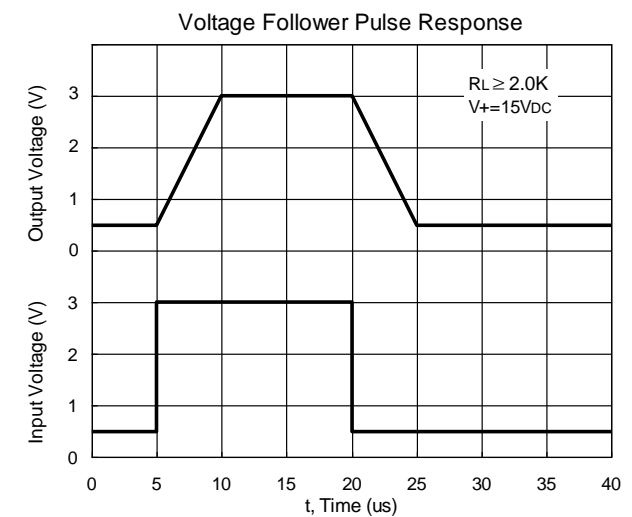
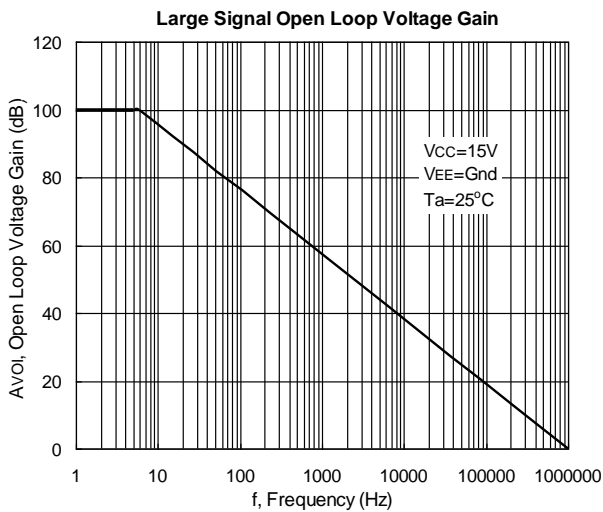
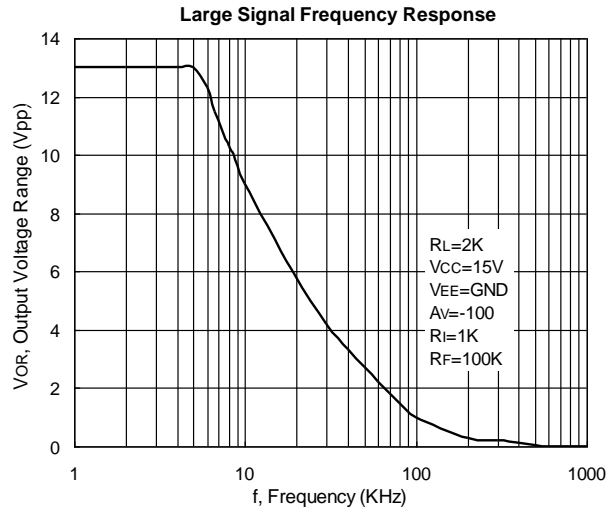
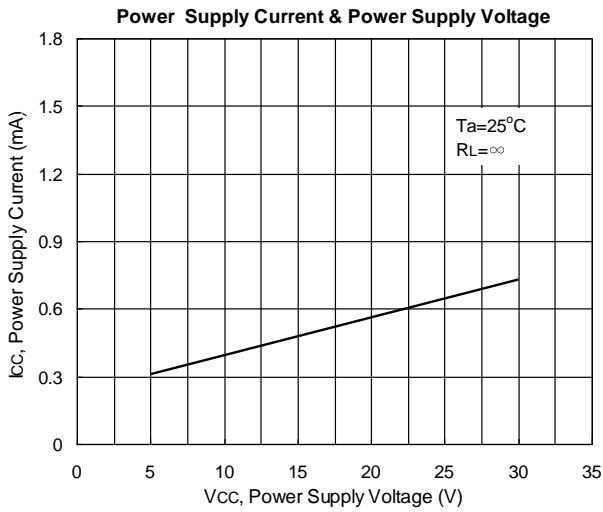

## CHARACTERISTICS CURVE

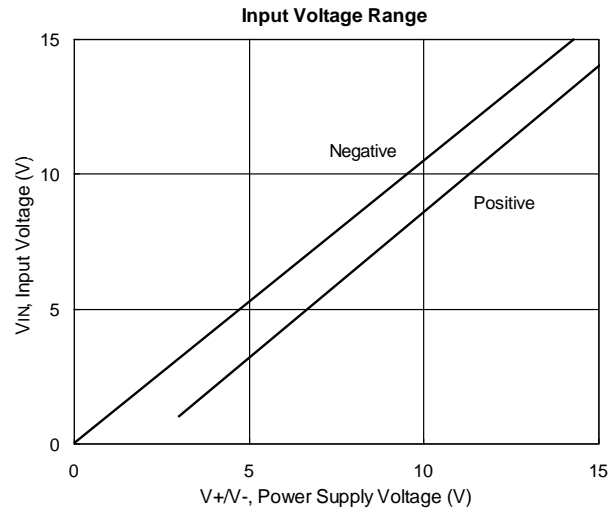
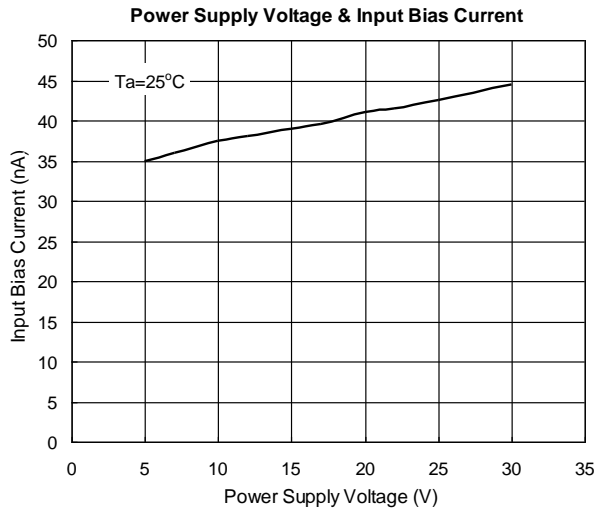

## ABSOLUTE MAXIMUM RATINGS

(Ta=25°C, unless otherwise specified)

Parameter	Symbol	Range	Units
Power Supply Voltage (Single Supply)	V <sub>CC</sub>	32	V <sub>DC</sub>
Power Supply Voltage (Split Supplies)	V <sub>CC</sub> , V <sub>EE</sub>	±16	V <sub>DC</sub>
Input Differential Voltage Range	V <sub>IDR</sub>	32	V <sub>DC</sub>
Input Common Mode Voltage Range	V <sub>ICR</sub>	-0.3 to +32	V <sub>DC</sub>
Output Short Circuit Duration	t <sub>SC</sub>	Continuous	
Junction Temperature	T <sub>J</sub>	150	°C
Storage Temperature Range	T <sub>stg</sub>	-40 to +150	°C
Operating Ambient Temperature Range	T <sub>A</sub>	-40 to +85	°C
Maximum Power Dissipation (DIP-8)	P <sub>D</sub>	800	mW
Maximum Power Dissipation (SO-8)		500	

# ELECTRICAL CHARACTERISTICS

( $V_{CC}=5V$ ,  $V_{EE}=\text{Ground}$ ,  $T_a=25^\circ\text{C}$ , unless otherwise specified)

Parameter	Symbol	Test Conditions	Min	Typ	Max	Unit
Input Offset Voltage	$V_{IO}$	$V_{CC}=5V\sim 30V$ , $V_{ICR}=0V\sim V_{CC}-1.5V$ , $V_O=1.4V$ , $R_S=0\Omega$	-	3	7	mV
Input Offset Current	$I_{IO}$	$I_{IN(+)}-I_{IN(-)}$	-	2	50	nA
Input Bias Current	$I_{IB}$	$I_{IN(+)}$ or $I_{IN(-)}$	-	20	250	nA
Large Signal Voltage Gain	$A_{VOL}$	$V_{CC}=15V$ , $R_L=2K\Omega$	25	100	-	V/mV
Common-Mode Rejection Ratio	CMR	$V_{CM}=0V\sim V_{CC}-1.5V$	65	80	-	dB
Channel Separation	CS	$1KHz\leq f\leq 20KHz$	-	120	-	dB
Power Supply Rejection	PSR	$V_{CC}=5V\sim 30V$	65	100	-	dB
Average Temperature Coefficient of Input Offset Voltage	$\Delta V_{IO}/\Delta T$	$R_S=0\Omega$	-	7	-	$\mu\text{V}/^\circ\text{C}$
Average Temperature Coefficient of Input Offset Current	$\Delta I_{IO}/\Delta T$	$R_S=0\Omega$	-	10	-	$\text{pA}/^\circ\text{C}$
Input Common Mode Voltage Range	$V_{ICR}$	$V_{CC}=30V$			$V_{CC}-2V$	V
Output Voltage (High Limit)	$V_{OH}$	$V_{CC}=30V$ , $R_L=2K\Omega$	26	27	-	V
		$V_{CC}=30V$ , $R_L=10K\Omega$	27	28	-	
Output Voltage (Low Limit)	$V_{OL}$	$R_L=10K\Omega$	-	5	20	mV
Supply current	$I_{CC}$	$R_L=\infty$ , $V_{CC}=30V$	-	0.7	1.2	mA
Output Source Current	$I_{Source}$	$V_{CC}=15V$ , $V_{IN+}=1V$ , $V_{IN-}=0V$ , $V_O=2V$	20	40	-	mA
Output Sink Current	$I_{Sink}$	$V_{CC}=15V$ , $V_{IN+}=0V$ , $V_{IN-}=1V$ , $V_O=2V$	10	20	-	mA
Power Supply Current	$I_{CC}$	$V_{CC}=30V$ , $T_a=T_{high}$ to $T_{low}$	-	1	2	mA
		$V_{CC}=5V$ , $T_a=T_{high}$ to $T_{low}$	-	0.7	1.2	mA
Output Short Circuit to Ground	$I_{SC}$	$V_{CC}=5V$ , GND at $-5V$ , $V_O=0V$	-	$\pm 40$	$\pm 60$	mA

# PACKAGE INFORMATION

8 PINS, SOP, 150MIL

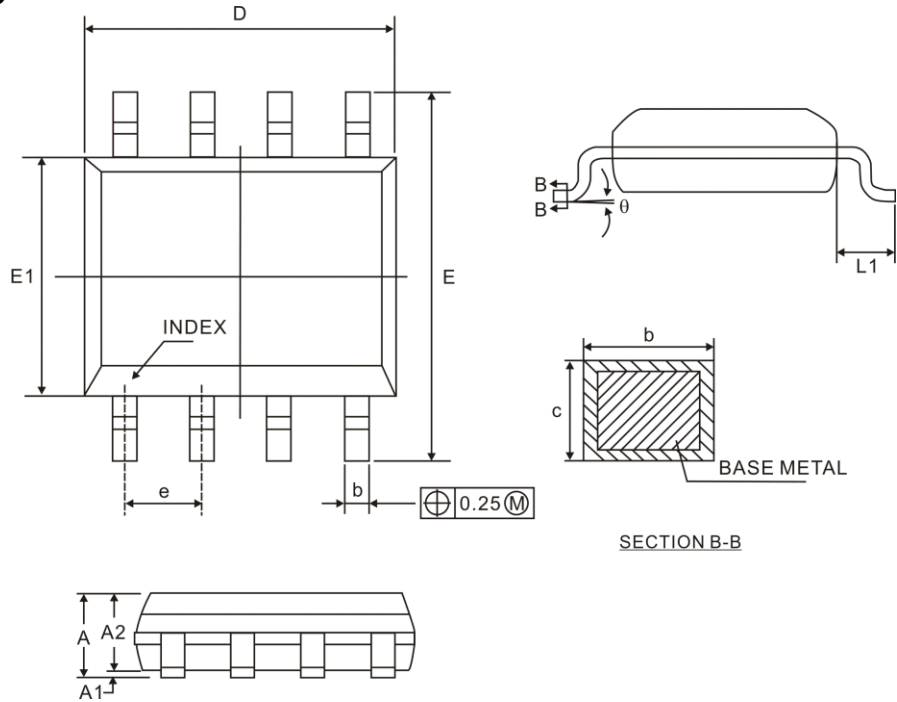

Symbol	Dimensions(mm)		
	Min.	Nom.	Max.
A	1.35	1.60	1.77
A1	0.08	0.15	0.28
A2	1.20	1.40	1.65
b	0.33	-	0.51
c	0.17	-	0.26
e	1.27 BSC		
D	4.70	4.90	5.10
E	5.80	6.00	6.20
E1	3.70	3.90	4.10
L1	1.04 REF		
theta	0°	-	8°

- Notes:  
 1. Refer to JEDEC MS-012  
 2. All dimensions are in millimeter

## IMPORTANT NOTICE

Princeton Technology Corporation (PTC) reserves the right to make corrections, modifications, enhancements, improvements, and other changes to its products and to discontinue any product without notice at any time.

PTC cannot assume responsibility for use of any circuitry other than circuitry entirely embodied in a PTC product. No circuit patent licenses are implied.

Princeton Technology Corp.  
2F, 233-1, Baociao Road,  
Sindian Dist, New Taipei City 23145, Taiwan  
Tel: 886-2-66296288  
Fax: 886-2-29174598  
<http://www.princeton.com.tw>