

DESCRIPTION

The RS431 series are three-terminal adjustable regulators with guaranteed thermal stability over applicable temperature ranges. The output voltage may be set to any value between V_{REF} (approximately 2.5V) and 36V with two external resistors. These devices have a typical dynamic output impedance of 0.2Ω . Active output circuitry provides a very sharp turn-on characteristic, making these devices excellent replacement for zener diodes in many applications.

FEATURES

- Programmable Precise Output Voltage from 2.5V to 36V
- High Stability under Capacitive Load
- Low Temperature Deviation: 4.5mV Typical
- Low Dynamic Output Resistance: 0.2Ω Typical
- Sink Current Capacity from 1mA to 100mA
- Low Output Noise
- Wide Operating Range of -40 to 125°C
- Low Equivalent Full-range Temperature Coefficient with 20PPM/ $^{\circ}\text{C}$ Typical

BLOCK DIAGRAM

Functional Block Diagram

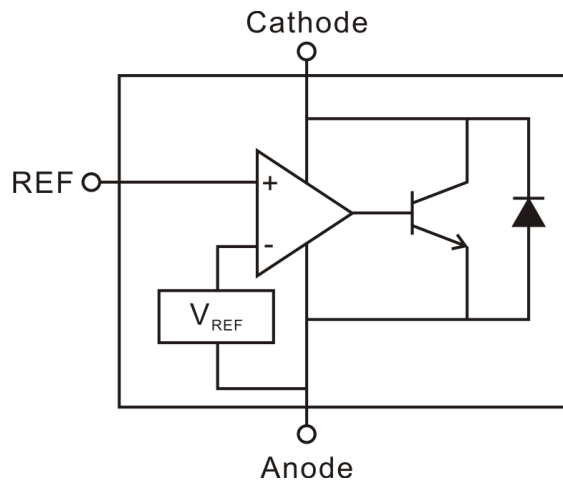

Symbol

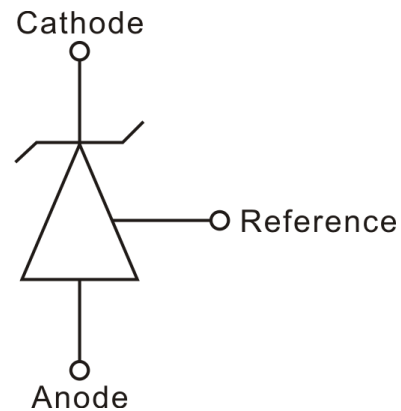

APPLICATION CIRCUIT

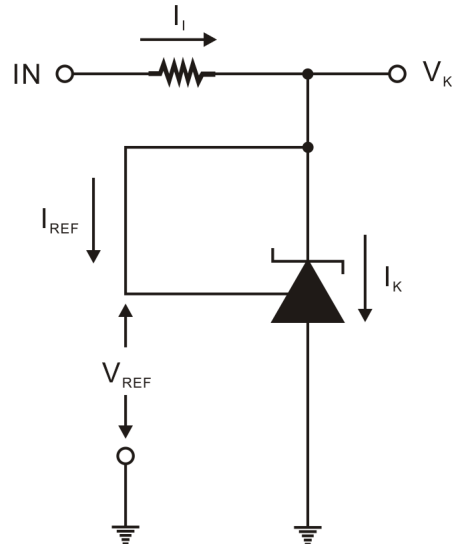

Figure 1. $V_K = V_{REF}$

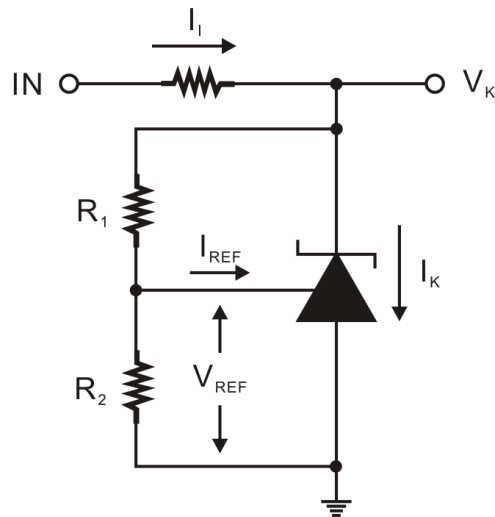

Figure 2. $V_K > V_{REF}$

Note: $V_K = V_{REF}(1 + R_1/R_2) + I_{REF} \times R_1$

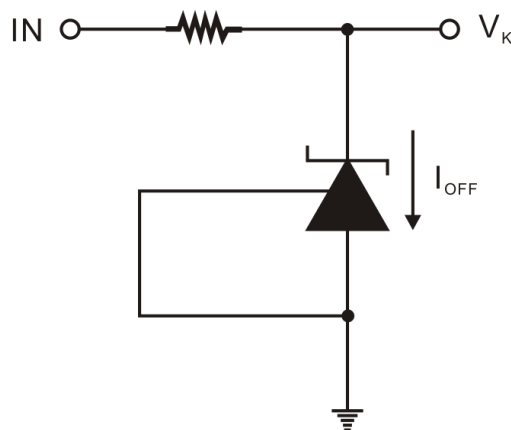

Figure 3. Off-State Current

ORDER INFORMATION

Device	Device Code
RS431 X YY Z	<p>X is Reference voltage precision designator: A: 2.5V±0.4% B: 2.5V±0.8%</p> <p>YY is package designator: A: TO-92 (Straight lead option) AT: TO-92 (Formed lead option) N: SOT-23</p> <p>Z is Lead Free designator: P: Commercial Standard, Lead (Pb) Free and Phosphorous (P) Free Package G: Green (Halogen Free with Commercial Standard)</p>

PIN ASSIGNMENTS

SOT-23

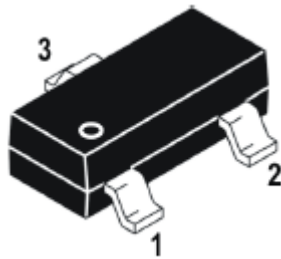

TO-92

(STRAIGHT LEAD OPTION)

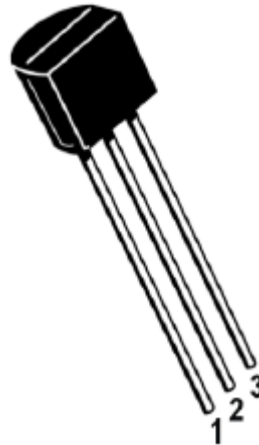

TO-92

(FORMED LEAD OPTION)

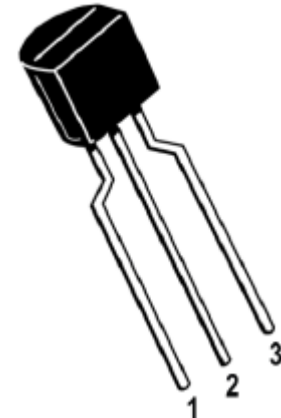

PIN DESCRIPTION

Package	Pin No.	Description
SOT-23	1	Reference
	2	Cathode
	3	Anode
TO-92	1	Reference
	2	Anode
	3	Cathode

ABSOLUTE MAXIMUM RATINGS

(Operating temperature range applies unless otherwise specified)

Parameter	Symbol	Ratings		Unit
Cathode voltage	V_{KA}	40		V
Cathode current range (Continuous)	I_K	-100 ~ +150		mA
Reference input current range	I_{REF}	0.05 ~ +10		mA
Power dissipation	P_D	SOT-23	370	mW
		TO-92	770	
Operating temperature range (Max.)	T_{OPR}	-40 ~ +125		°C
Storage temperature range	T_{STG}	-40 ~ +150		°C

OPERATING CONDITIONS

Parameter	Symbol	Min.	Max.	Unit
Cathode voltage	V_{KA}	V_{REF}	36	V
Cathode current range (Continuous)	I_K	1	100	mA
Operating ambient temperature range	T_{OPR}	-40	125	°C

ELECTRICAL CHARACTERISTICS

($T_A=25^\circ\text{C}$, unless otherwise specified)

Characteristics		Symbol	Test Condition	Min.	Typ.	Max.	Unit
Reference input voltage (Figure 1)	2.5V±0.4%	V_{REF}	$V_K=V_{REF}, I_K=10\text{mA}$	2.49	2.50	2.51	V
	2.5V±0.8%			2.48	2.50	2.52	
Deviation of reference input voltage over-temperature (Figure 1)		$V_{REF(dev)}$	$V_K=V_{REF}, I_K=10\text{mA}$ $T_{MIN} \leq T_A \leq T_{MAX} (-40 \sim +125^\circ\text{C})$	-	4.5	16	mV
Ratio of change in reference input voltage to the change in cathode voltage (Figure 2)		$\Delta V_{REF}/\Delta V_K$	$I_K=10\text{mA}, \Delta V_K=10\text{V} \sim V_{REF}$	-	1.0	2.7	mV/V
			$I_K=10\text{mA}, \Delta V_K=36\text{V} \sim 10\text{V}$	-	0.5	2.0	
Reference input current (Figure 2)		I_{REF}	$I_K=10\text{mA}, R_1=10\text{K}\Omega, R_2=\infty$	-	0.7	4	
Deviation of reference input current over full temperature range (Figure 2)		$I_{REF(dev)}$	$I_K=10\text{mA}, R_1=10\text{K}\Omega$ $R_2=\infty, T_A=-40 \sim +125^\circ\text{C}$	-	0.4	1.2	μA
Minimum cathode current for regulation (Figure 1)		$I_{K(min)}$	$V_K=V_{REF}$	-	0.4	1.0	mA
Off-state cathode current (Figure 3)		$I_{K(off)}$	$V_K=36\text{V}, V_{REF}=0$	-	0.05	1.0	μA
Dynamic output impedance (Figure 1)		Z_K	$V_K=V_{REF}, f \leq 1\text{KHz}, I_K=1 \sim 100\text{mA}$	-	0.15	0.5	Ω

TYPICAL PERFORMANCE CHARACTERISTICS

Delta Reference Voltage vs. Temperature

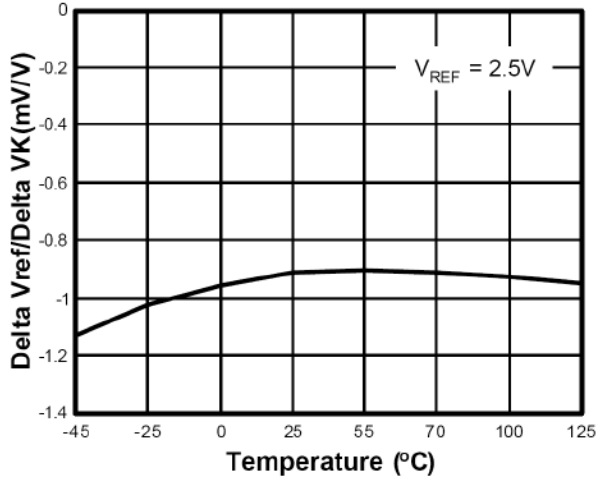

Off-State Current vs. Temperature

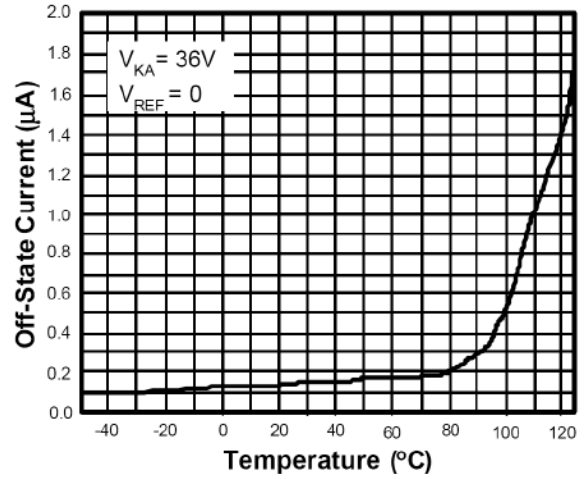

Impedance vs. Temperature

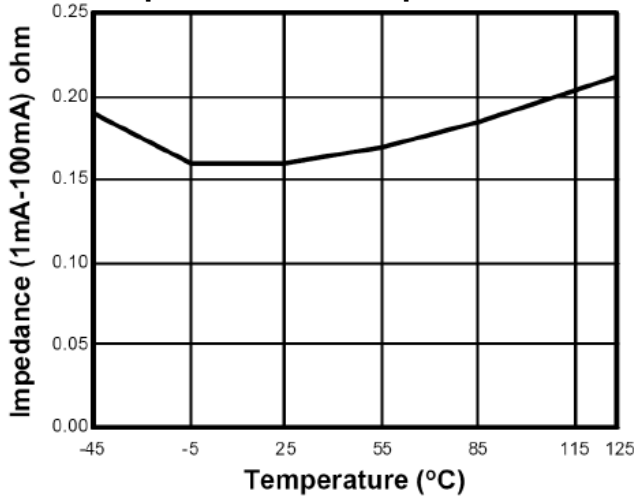

Reference Voltage vs. Temperature

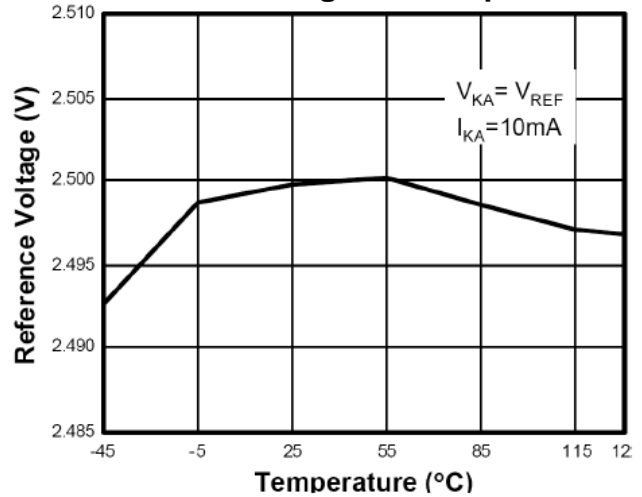

Cathode Current vs. Cathode Voltage

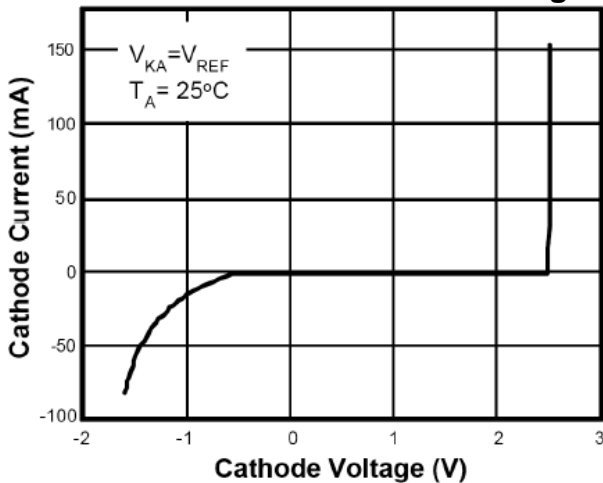

Current vs. Cathode Voltage

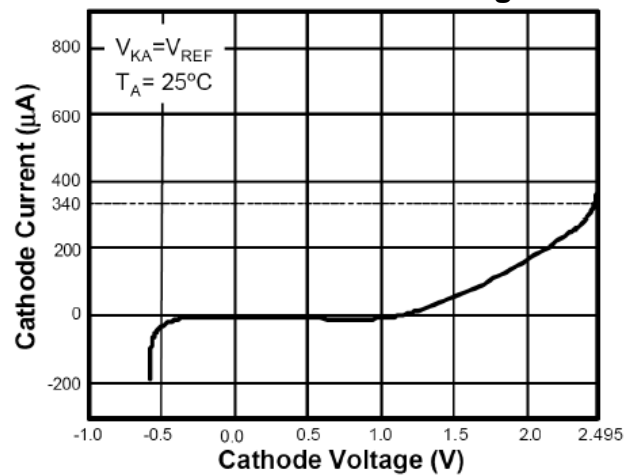

Reference Current vs. Temperature

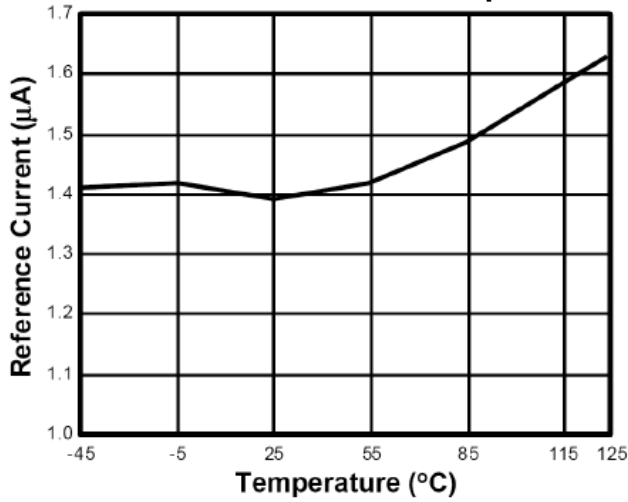

Reference Voltage vs. Cathode Current

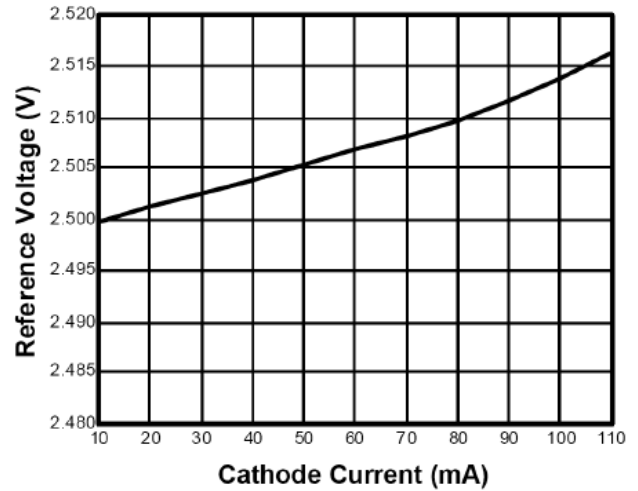

Small Signal Voltage Gain vs. Frequency

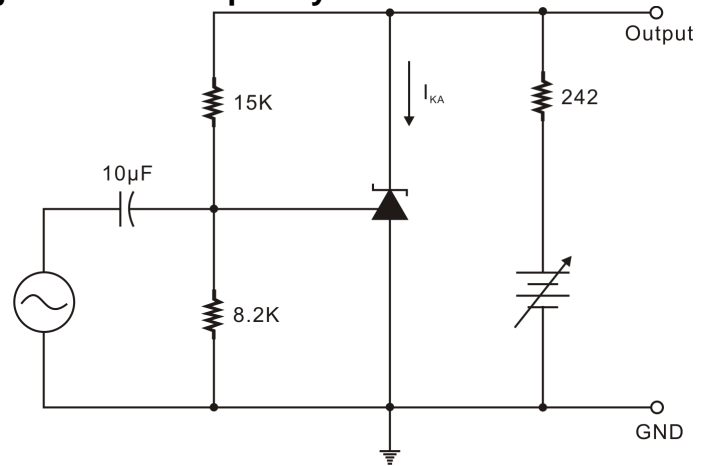
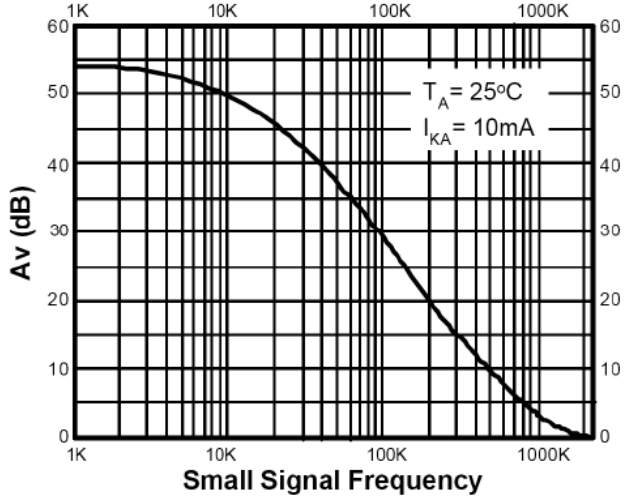

Pulse Response of Input and Output Voltage

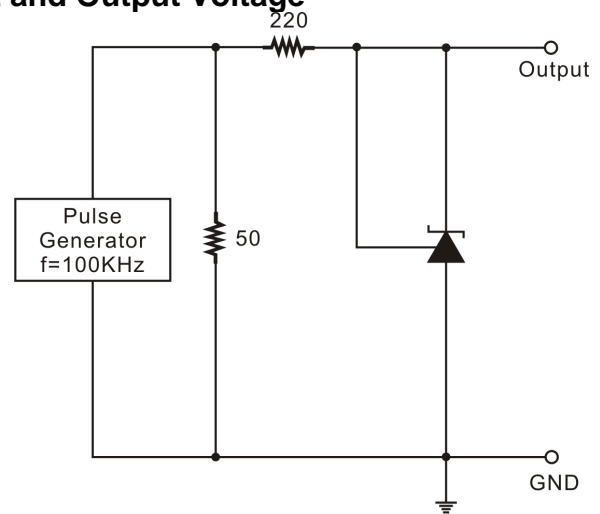
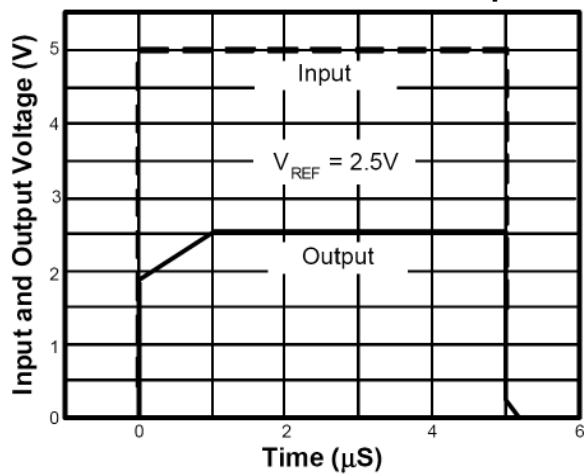

Reference Impedance vs. Frequency

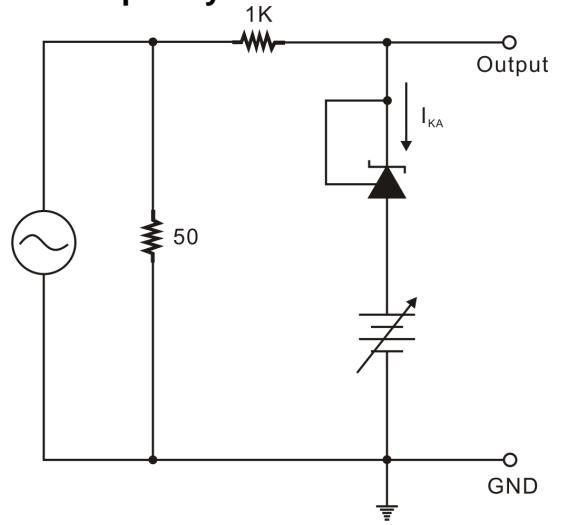
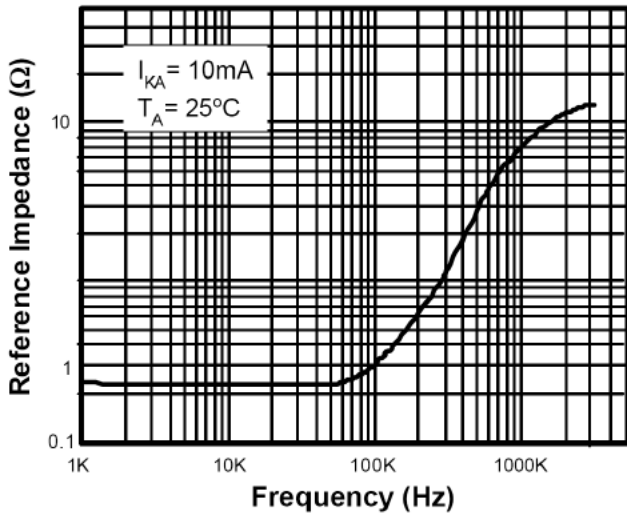

Stability Boundary Conditions vs. Load Capacitance

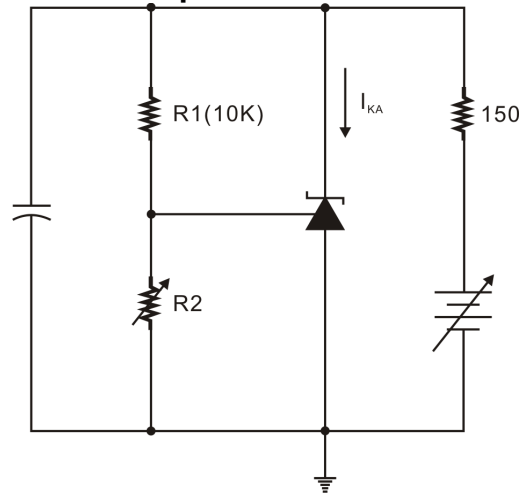
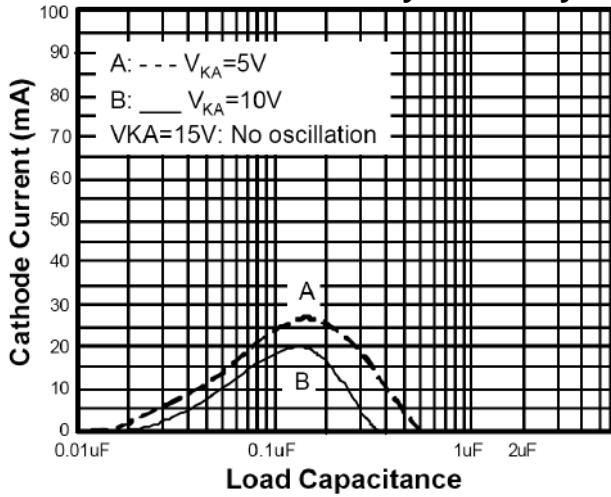

PACKAGE INFORMATION

3-PIN, SOT-23

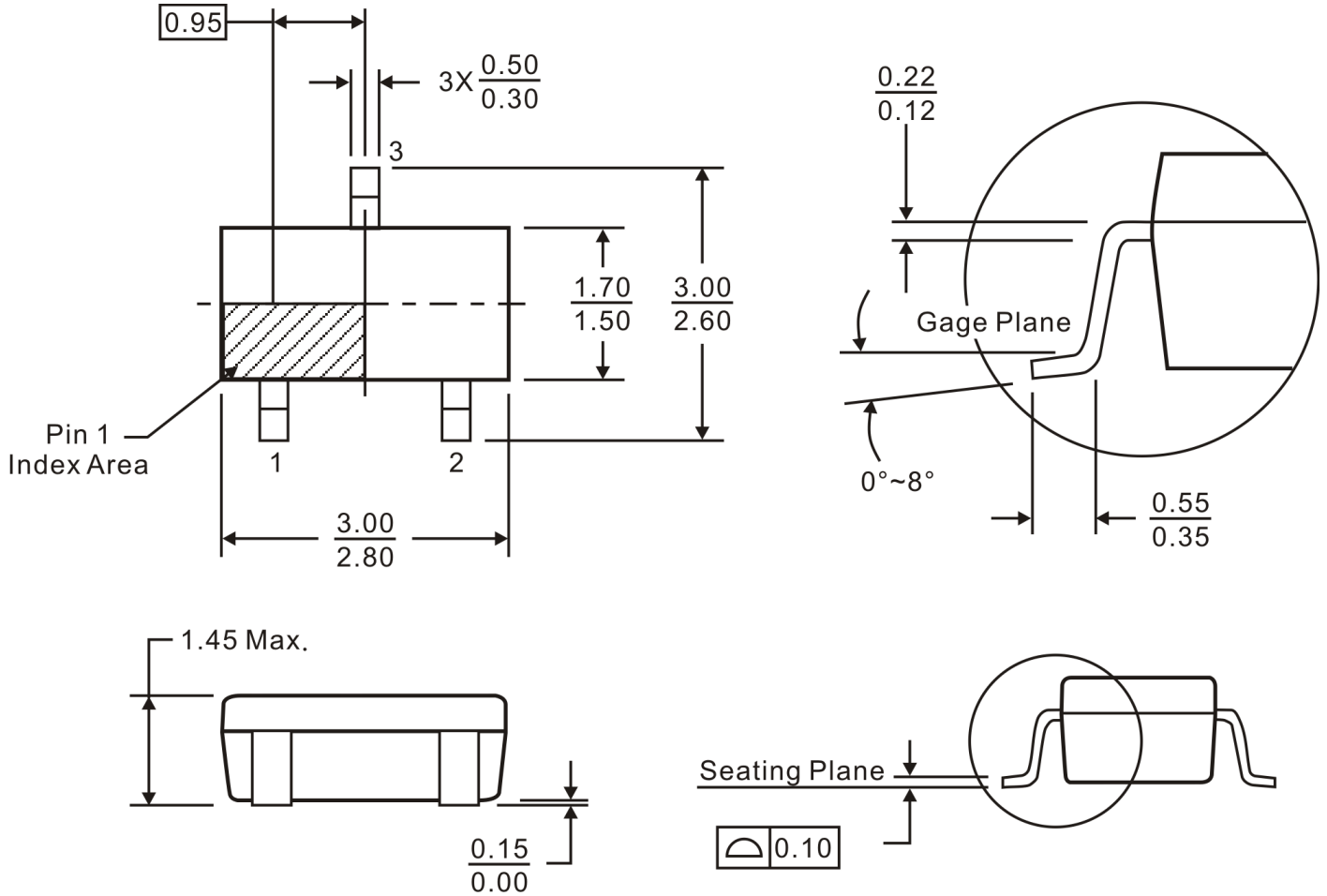

Note: All dimensions are in millimeter.

3-PIN, TO-92

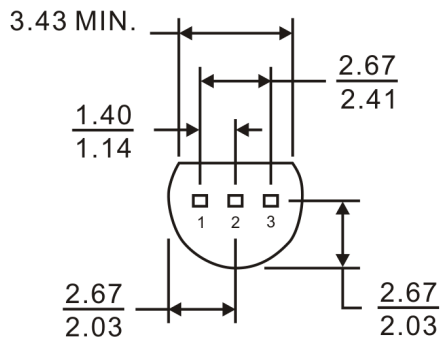
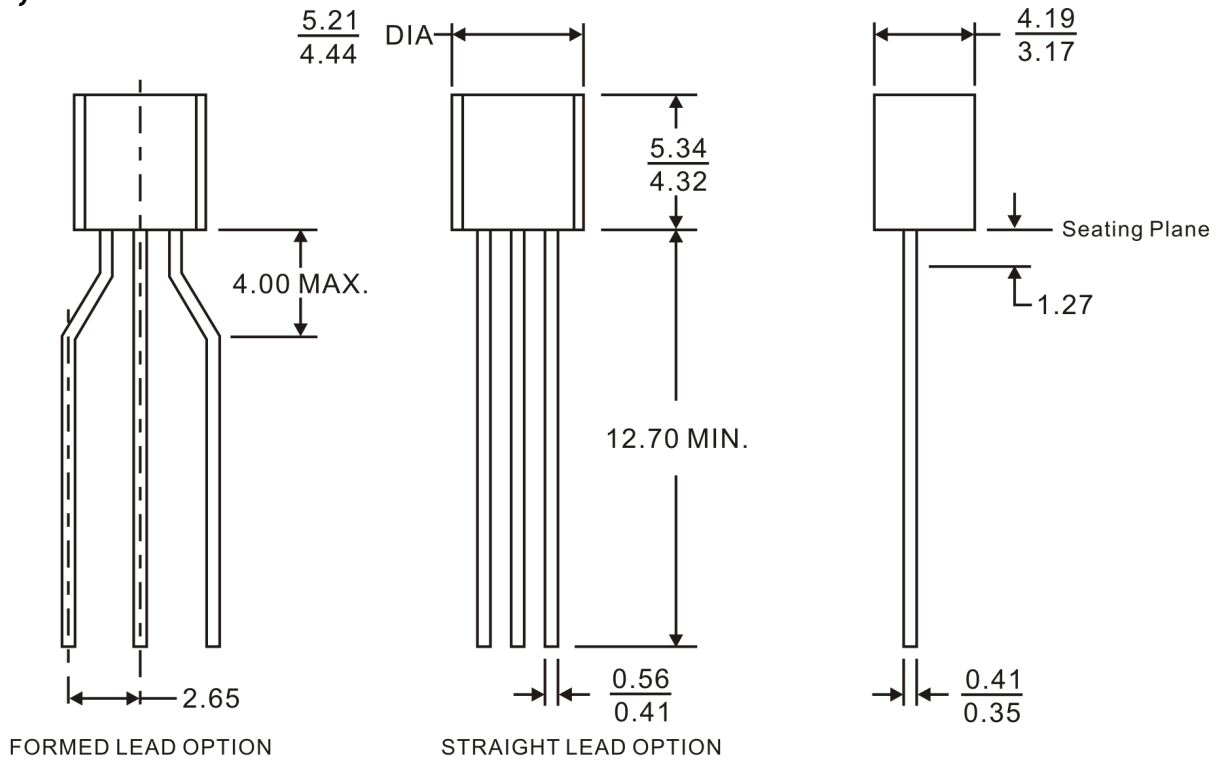

Notes:
 1. Refer to JEDEC TO-226 AA.
 2. All dimensions are in millimeter.

IMPORTANT NOTICE

Princeton Technology Corporation (PTC) reserves the right to make corrections, modifications, enhancements, improvements, and other changes to its products and to discontinue any product without notice at any time.

PTC cannot assume responsibility for use of any circuitry other than circuitry entirely embodied in a PTC product. No circuit patent licenses are implied.

Princeton Technology Corp.
2F, 233-1, Baociao Road,
Sindian Dist., New Taipei City 23145, Taiwan
Tel: 886-2-66296288
Fax: 886-2-29174598
<http://www.princeton.com.tw>